

Service Manual

Tektronix

2247A Portable Oscilloscope

070-6367-00

Warning

The servicing instructions are for use by qualified personnel only. To avoid personal injury, do not perform any servicing unless you are qualified to do so. Refer to the Safety Summary prior to performing service.

Please check for change information at the rear of this manual.

First Printing: December 1989
Revised Printing: December 1992

Instrument Serial Numbers

Each instrument manufactured by Tektronix has a serial number on a panel insert or tag, or stamped on the chassis. The first letter in the serial number designates the country of manufacture. The last five digits of the serial number are assigned sequentially and are unique to each instrument. Those manufactured in the United States have six unique digits. The country of manufacture is identified as follows:

B010000	Tektronix, Inc., Beaverton, Oregon, USA
E200000	Tektronix United Kingdom, Ltd., London
J300000	Sony/Tektronix, Japan
H700000	Tektronix Holland, NV, Heerenveen, The Netherlands

Instruments manufactured for Tektronix by external vendors outside the United States are assigned a two digit alpha code to identify the country of manufacture (e.g., JP for Japan, HK for Hong Kong, IL for Israel, etc.).

Tektronix, Inc., P.O. Box 500, Beaverton, OR 97077

Printed in U.S.A.

Copyright © Tektronix, Inc., 1989. All rights reserved. Tektronix products are covered by U.S. and foreign patents, issued and pending. The following are registered trademarks: TEKTRONIX, TEK, TEKPROBE, and SCOPE-MOBILE.

WARRANTY

Tektronix warrants that this product will be free from defects in materials and workmanship for a period of three (3) years from the date of shipment. If any such product proves defective during this warranty period, Tektronix, at its option, either will repair the defective product without charge for parts and labor, or will provide a replacement in exchange for the defective product.

In order to obtain service under this warranty, Customer must notify Tektronix of the defect before the expiration of the warranty period and make suitable arrangements for the performance of service. Customer shall be responsible for packaging and shipping the defective product to the service center designated by Tektronix, with shipping charges prepaid. Tektronix shall pay for the return of the product to Customer if the shipment is to a location within the country in which the Tektronix service center is located. Customer shall be responsible for paying all shipping charges, duties, taxes, and any other charges for products returned to any other locations.

This warranty shall not apply to any defect, failure or damage caused by improper use or improper or inadequate maintenance and care. Tektronix shall not be obligated to furnish service under this warranty a) to repair damage resulting from attempts by personnel other than Tektronix representatives to install, repair or service the product; b) to repair damage resulting from improper use or connection to incompatible equipment; or c) to service a product that has been modified or integrated with other products when the effect of such modification or integration increases the time or difficulty of servicing the product.

THIS WARRANTY IS GIVEN BY TEKTRONIX WITH RESPECT TO THIS PRODUCT IN LIEU OF ANY OTHER WARRANTIES, EXPRESSED OR IMPLIED. TEKTRONIX AND ITS VENDORS DISCLAIM ANY IMPLIED WARRANTIES OF MERCHANTABILITY OR FITNESS FOR A PARTICULAR PURPOSE. TEKTRONIX' RESPONSIBILITY TO REPAIR OR REPLACE DEFECTIVE PRODUCTS IS THE SOLE AND EXCLUSIVE REMEDY PROVIDED TO THE CUSTOMER FOR BREACH OF THIS WARRANTY. TEKTRONIX AND ITS VENDORS WILL NOT BE LIABLE FOR ANY INDIRECT, SPECIAL, INCIDENTAL, OR CONSEQUENTIAL DAMAGES IRRESPECTIVE OF WHETHER TEKTRONIX OR THE VENDOR HAS ADVANCE NOTICE OF THE POSSIBILITY OF SUCH DAMAGES.

*This Document is a complete Scan from the original
Tektronix manual*

*For enquiries about our complete
High quality line of technical Manuals in PDF*

mailto : Qservice@otenet.gr

**SEE
OTHER
SIDE**

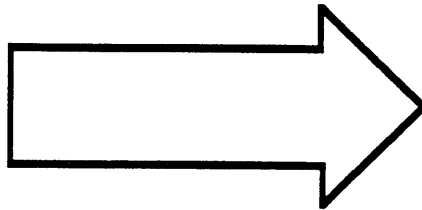

TABLE OF CONTENTS

	Page		Page
LIST OF ILLUSTRATIONS	iv	VERTICAL PREAMPS AND OUTPUT AMPLIFIER (Diagram 2)	3-4
LIST OF TABLES	v	A AND B TRIGGER SYSTEM (Diagram 3)	3-4
OPERATORS SAFETY SUMMARY	vi	DISPLAY AND TRIGGER LOGIC AND PROCESSOR INTERFACE (Diagram 4)	3-5
SERVICING SAFETY SUMMARY	vii	A AND B SWEEPS AND DELAY COMPARATORS (Diagram 5)	3-5
Section 1 SPECIFICATION		HORIZONTAL OUTPUT AMPLIFIER (Diagram 6)	3-6
INTRODUCTION	1-1	Z-AXIS, CRT, PROBE ADJUST, AND CONTROL MUX (Diagram 7)	3-6
STANDARD ACCESSORIES	1-1	MEASUREMENT PROCESSOR (Diagram 8)	3-7
RECOMMENDED CALIBRATION		READOUT SYSTEM (Diagram 9)	3-7
SCHEDULE	1-2	SWITCH BOARD AND INTERFACE (Diagram 10)	3-7
PERFORMANCE		ADC AND DAC SYSTEM (Diagram 11)	3-8
CONDITIONS	1-2	COUNTER/TIMER (Diagram 12)	3-8
Section 2 PREPARATION FOR USE		DAC SUBSYSTEM (Diagram 13)	3-9
SAFETY	2-1	POWER SUPPLY (Diagram 14)	3-9
LINE VOLTAGE AND POWER CORD	2-1	DETAILED CIRCUIT DESCRIPTION	3-9
LINE FUSE	2-1	VERTICAL INPUTS (Diagram 1)	3-9
INSTRUMENT COOLING	2-2	VERTICAL PREAMPS AND OUTPUT AMPLIFIER (Diagram 2)	3-13
START-UP	2-2	A AND B TRIGGER SYSTEM (Diagram 3)	3-15
DETAILED OPERATING INFORMATION	2-2	DISPLAY AND TRIGGER LOGIC AND PROCESSOR INTERFACE (Diagram 4)	3-19
Section 3 THEORY OF OPERATION			
SECTION ORGANIZATION	3-1		
INTEGRATED CIRCUIT DESCRIPTIONS	3-1		
BLOCK DIAGRAM DESCRIPTION			
INTRODUCTION	3-1		
VERTICAL INPUTS (Diagram 1)	3-1		

	Page		Page
A AND B SWEEPS AND DELAY COMPARATORS (Diagram 5)	3-33	MEASUREMENT CURSORS	4-23
HORIZONTAL OUTPUT AMPLIFIER (Diagram 6)	3-39	CH 1/CH 2 VOLTMETER	4-25
Z-AXIS, CRT, PROBE ADJUST, AND CONTROL MUX (Diagram 7)	3-40	COUNTER/TIMER	4-28
MEASUREMENT PROCESSOR (Diagram 8)	3-44	EXTERNAL Z-AXIS, PROBE ADJUST, AND AUTO SETUP FUNCTIONS	4-30
READOUT SYSTEM (Diagram 9)	3-48		
SWITCH BOARD AND INTERFACE (Diagram 10)	3-54	Section 5 ADJUSTMENT PROCEDURE	
ADC AND DAC SYSTEM (Diagram 11)	3-55	INTRODUCTION	5-1
COUNTER/TIMER (Diagram 12)	3-55	PURPOSE	5-1
DAC SUBSYSTEM (Diagram 13)	3-57	TEST EQUIPMENT REQUIRED	5-1
POWER SUPPLY (Diagram 14)	3-58	LIMITS AND TOLERANCES	5-1
MAIN BOARD POWER DISTRIBUTION (Diagram 15)	3-63	PARTIAL PROCEDURES	5-1
PROCESSOR BOARD POWER DISTRIBUTION (Diagram 16) ..	3-63	INTERNAL ADJUSTMENTS AND ADJUSTMENT INTERACTION	5-1
INTERCONNECTION DIAGRAM (Diagram 17)	3-63	PREPARATION FOR ADJUSTMENT	5-3
		INDEX TO ADJUSTMENT PROCEDURE	5-3
Section 4 PERFORMANCE CHECK PROCEDURE		POWER SUPPLY, DISPLAY, AND Z-AXIS	5-4
INTRODUCTION	4-1	INITIAL CONTROL SETTINGS	5-4
TEST EQUIPMENT REQUIRED	4-1	PROCEDURE	5-4
PERFORMANCE CHECK INTERVAL	4-1	VERTICAL	5-6
PREPARATION	4-1	INITIAL CONTROL SETTINGS	5-6
INDEX TO PERFORMANCE CHECK PROCEDURE	4-4	PROCEDURE	5-6
DISPLAY	4-5	HORIZONTAL	5-11
VERTICAL	4-6	INITIAL CONTROL SETTINGS	5-11
TRIGGERING	4-14	PROCEDURE	5-11
HORIZONTAL	4-18	MEASUREMENT BANDWIDTH AND SELF CHARACTERIZATION	5-13
		INITIAL CONTROL SETTINGS	5-13
		PROCEDURE	5-13
		COUNTER/TIMER	5-15
		INITIAL CONTROL SETTINGS	5-15
		PROCEDURE	5-15

LIST OF ILLUSTRATIONS

Figure	Page
The 2247A Oscilloscope.	
1-1	Maximum input voltage vs frequency derating curve for the CH 1, CH 2, CH 3, or CH 4 input connector 1-20
1-2	Dimensional outline drawing, standard cabinet 1-24
1-3	Dimensional outline drawing, rackmount cabinet 1-25
2-1	Optional power cords 2-1
3-1	Simplified block diagram 3-2
3-2	Display Sequencer IC (SLIC, U600) pin out diagram 3-20
3-3	Readout interface relative signal timing 3-28
3-4	Trigger Logic IC (FLIC, U602) pin out diagram 3-29
3-5	Simplified Sweep Circuit 3-34
3-6	A Sweep Start circuit waveforms 3-38
3-7	Simplified diagram of the DC Restorer circuitry 3-42
3-8	Display addresses 3-50
3-9	Character pixel arrangement 3-53
3-10	Power Supply block diagram 3-59
3-11	Preregulator switching waveforms 3-62
5-1	Areas of waveform affected by HF compensation 5-9
5-2	2 ns Timing 5-12
5-3	Processor board adjustment location 5-16
6-1	Power-on test failure codes 6-10
6-2	Main SERVICE MENU 6-11
6-3	SERVICE MENU with DIAGNOSE choice selected 6-12
6-4	Main board removal 6-46
6-5	Delay-line connections to top of Main board 6-47
9-1	Color codes for resistors.
9-2	Semiconductor lead configurations.
9-3	Locating components on schematic diagram and circuit board illustrations.
9-4a	Detailed block diagram—part 1.
9-4b	Detailed block diagram—part 2.
9-5	A10—Main board.
9-6	Hybrid pin identifiers.
9-7	A8—CRT control board.
9-8	A16—Processor board.
9-9	A14—Switch board.
9-10	A12—Potentiometer board.
9-11	A15—DAC Subsystem board.
9-12	A18—Power Supply board.
9-13	Main board adjustment locations.

LIST OF TABLES

Table	Page
1-1 Electrical Characteristics	1-3
1-2 Environmental Characteristics	1-21
1-3 Mechanical Characteristics	1-22
3-1 Shift Register 0 Bit Assignment	3-11
3-2 CH 1 and CH 2 Attenuator and Gain Control Bit States	3-12
3-3 Input Coupling Control Bit States	3-12
3-4 CH 2 INVERT Control Bit	3-12
3-5 CH 3 and CH 4 Gain Control Bit	3-12
3-6 Trigger Selection Logic	3-17
3-7 Display Sequencer (U600) Control Bit Assignments	3-21
3-8 A Trigger Source Select Bits	3-22
3-9 Horizontal Display Mode Select Bits	3-22
3-10 Shift Register 1 Control Bit Data	3-23
3-11 Trigger Source Select	3-24
3-12 Vertical MODE Select	3-24
3-13 Horizontal MODE Select	3-24
3-14 Holdoff Counter Encoding	3-25
3-15 Display Sequencer Channel Select Logic Bits	3-26
3-16 Horizontal and Vertical Display Response	3-27
3-17 Trigger Logic IC Addressing Logic	3-30
3-18 Control Register Signal-bit Names	3-30
3-19 Delay Mode Selection Control Bits	3-31
3-20 Peak Volts Detection Mode Logic	3-31
3-21 Z-Axis Switching Logic	3-33
3-22 A Sweep Timing Selections	3-36
3-23 B Sweep Timing Selections	3-37
3-24 HD0 and HD1 Logic	3-39
3-25 Front-Panel Multiplexer Channel Select Bits	3-43
3-26 Measurement Processor Signals	3-47
3-27 Position Enable Bit Assignment	3-51
3-28 Field and Mixer Attribute Bit Assignment	3-52
3-29 Display Possibilities	3-53
3-30 Possible Signal Conditions to U2416	3-54
4-1 Test Equipment Required	4-2
4-2 Signal-to-Graticule Accuracy	4-8
4-3 Settings for Timing Accuracy Checks	4-20
4-4 Delay Time Accuracy	4-21
5-1 Adjustment Interactions	5-2
5-2 Power Supply Voltage Limits	5-4
6-1 Relative Susceptibility to Static-Discharge Damage	6-1
6-2 External Inspection Checklist	6-3
6-3 Internal Inspection Checklist	6-3
6-4 Power Supply Voltage and Ripple Limits	6-8
6-5 SERVICE MENU Selections	6-13
6-6 DIAGNOSE ROUTINES	6-17
6-7 Horizontal Display State Logic	6-25
6-8 Measurement Processor I/O Memory Map	6-26
6-9 Measurement Error Troubleshooting Hints	6-30
6-10 Maintenance Aids	6-39

OPERATORS SAFETY SUMMARY

The safety information in this summary is for operating personnel. Warnings and cautions will also be found throughout the manual where they apply.

Terms in This Manual

CAUTION statements identify conditions or practices that could result in damage to the equipment or other property.

WARNING statements identify conditions or practices that could result in personal injury or loss of life.

Terms as Marked on Equipment

CAUTION indicates a personal injury hazard not immediately accessible as one reads the markings, or a hazard to property, including the equipment itself.

DANGER indicates a personal injury hazard immediately accessible as one reads the marking.

Symbols in This Manual



This symbol indicates where applicable cautionary or other information is to be found. For maximum input voltage see Table 1-1.

Symbols as Marked on Equipment



DANGER—High voltage.



Protective ground (earth) terminal.



ATTENTION—Refer to manual.

Power Source

This product is intended to operate from a power source that does not apply more than 250 V rms between the supply conductors or between either supply conductor and ground. A protective ground connection, by way of the grounding conductor in the power cord, is essential for safe operation.

Grounding the Product

This product is grounded through the grounding conductor of the power cord. To avoid electrical shock, plug the power cord into a properly wired receptacle before making any connections to the product input or output terminals. A protective ground connection, by way of the grounding conductor in the power cord, is essential for safe operation.

Danger Arising From Loss of Ground

Upon loss of the protective-ground connection, all accessible conductive parts, including knobs and controls that may appear to be insulating, can render an electric shock.

Use the Proper Power Cord

Use only the power cord and connector specified for your product.

Use only a power cord that is in good condition.

For detailed information on power cords and connectors, see Figure 2-1.

Use the Proper Fuse

To avoid fire hazard, use only a fuse of the correct type, voltage rating and current rating as specified in the parts list for your product.

Do Not Operate in an Explosive Atmosphere

To avoid explosion, do not operate this instrument in an explosive atmosphere.

Do Not Remove Covers or Panels

To avoid personal injury, do not remove the product covers or panels. Do not operate the product without the covers and panels properly installed.

SERVICING SAFETY SUMMARY

FOR QUALIFIED SERVICE PERSONNEL ONLY

Refer also to the preceding Operators Safety Summary

Do Not Service Alone

Do not perform internal service or adjustment of this product unless another person capable of rendering first aid and resuscitation is present.

Use Care When Servicing With Power On

Dangerous voltages exist at several points in this product. To avoid personal injury, do not touch exposed connections or components while power is on.

Disconnect power before removing protective panels, soldering, or replacing components.

Power Source

This product is intended to operate from a power source that does not apply more than 250 volts rms between the supply conductors or between either supply conductor and ground. A protective ground connection by way of the grounding connector in the power cord is essential for safe operation.

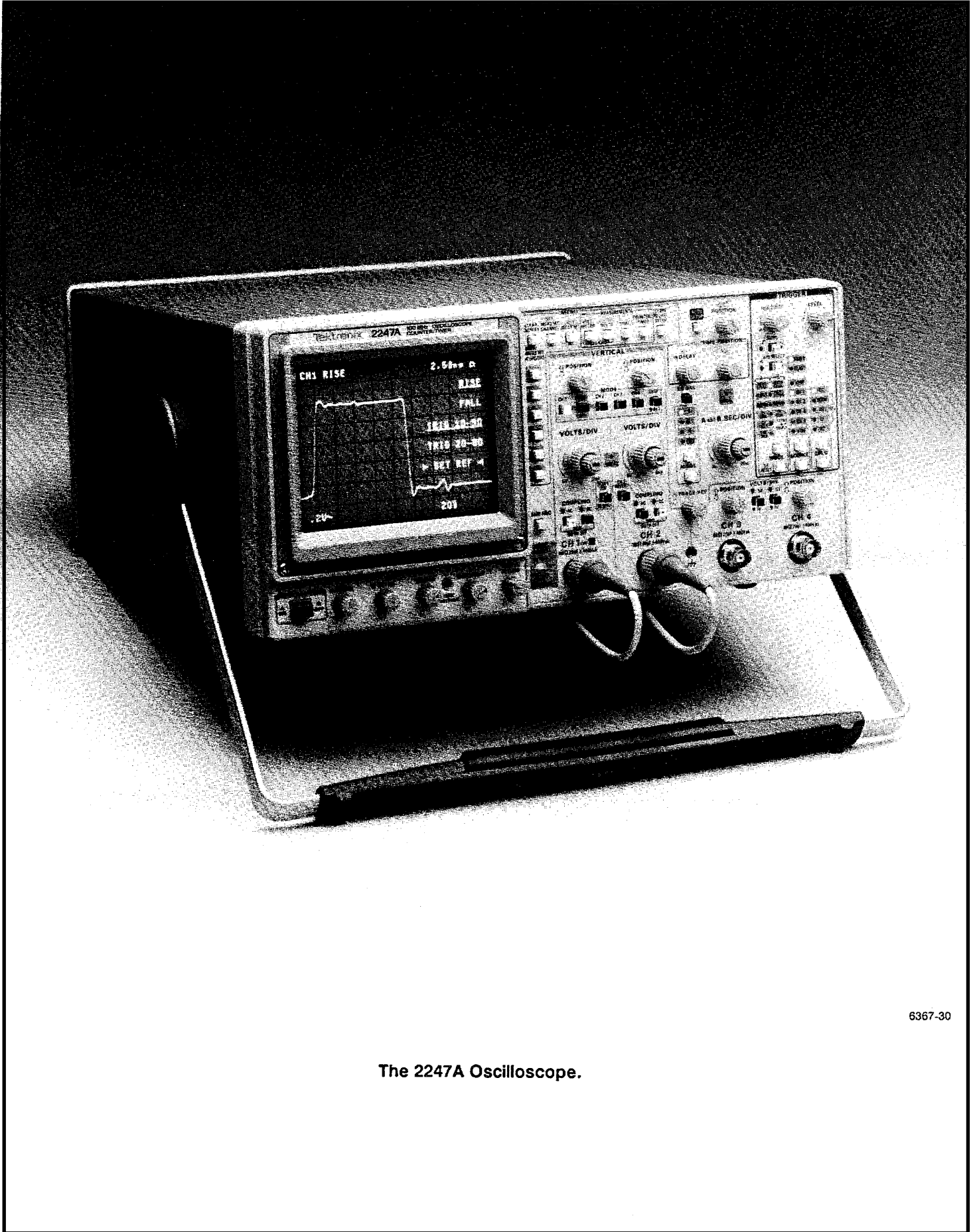

6367-30

The 2247A Oscilloscope.

SPECIFICATION

INTRODUCTION

The TEKTRONIX 2247A is a 100 MHz, four-channel, dual-sweep, portable oscilloscope for general-purpose use. A microprocessor-based operating system controls most of the functions in the instrument, including a fully integrated menu-driven voltage and time measurement system with SmartCursors™. A counter/timer (C/T) is integrated into the trigger system to provide many automated counting and timing measurements. Other features include single-button automatic front-panel setup and a menu-driven store/recall setup function. A menu-driven service mode provides for configuring of certain menu and readout displays and running the internal calibration and servicing diagnostic routines.

The vertical deflection system has four input channels. Two channels have 11 basic deflection factors from 2 mV to 5 V per division, and two channels have two basic deflection factors of 0.1 V and 0.5 V per division. Basic deflection factors can be extended with attenuator probes. VOLTS/DIV readouts are switched to display the correct vertical scale factors when properly coded probes are connected to the vertical input connectors.

The horizontal deflection system provides single, dual, or delayed sweeps from 0.5 s to 20 ns per division (delayed sweep, 5 ms to 20 ns per division). The trigger system provides stable triggering over the full bandwidth of the vertical deflection system.

Alphanumeric crt readouts of the vertical and horizontal scale factors are displayed at the bottom of the screen. On-screen vertical and horizontal cursors provide accurate voltage, time, frequency, and phase measurements; measurement values are displayed at the top of the crt.

Measurement features include cursor-driven voltage, time, frequency, and phase measurements; counter/timer measurements; and automatic rise time/fall time and propagation delay measurements. Voltage measurements include positive peak, negative peak, peak-to-peak, and average dc levels, measured over the entire display or a selected portion (gated measurements).

Counter/timer measurements include frequency, period, width, totalize, frequency ratio, gated frequency, gated period, gated width, gated events, delta time, one-over-delta time, phase, rise time/fall time, and propagation delay, using an internal or external frequency standard. Counter/timer measurements can be averaged to increase the number of displayed digits, and measurement trigger points can be indicated with cursors on screen.

Positionable cursors allow absolute voltage, voltage difference, time difference, frequency, and phase measurements. SmartCursors™ that visually track voltage measurements, trigger levels, and ground can be selectively displayed with the waveforms. Time, frequency, and phase measurements referenced to the trigger event or between two user-selected events are available in ALT and B horizontal modes.

By pressing a single button (AUTO SETUP), the front-panel controls can be set up to produce a usable waveform display based on the voltage and time characteristics of the input signals.

The Store/Recall system lets you store and recall up to 20 different front-panel setups. Stored setups can be arranged in sequences as required for specific applications.

STANDARD ACCESSORIES

The following items are standard accessories shipped with the 2247A instrument:

- 2 Probes, 10X, 1.5 meter, with accessories
- 1 Power cord
- 1 Power cord clamp
- 1 Operators manual
- 1 Reference guide
- 1 Crt implosion shield, blue plastic (installed)
- 1 Fuse, 2A, 250 V, slow-blow
- 1 Accessory pouch, ziploc

Refer to the Accessories page at the back of this manual for part numbers and further information about both standard and optional accessories. Available options are described in Section 7. Your Tektronix representative, local Tektronix Field Office, or Tektronix

products catalog can provide additional information on options and accessories.

RECOMMENDED CALIBRATION SCHEDULE

To ensure accurate measurements, check the performance of this instrument every 2000 hours of operation (once each year if used infrequently). When components are replaced, affected circuits may have to be readjusted.

PERFORMANCE CONDITIONS

The electrical characteristics given in Table 1-1 are valid when the instrument has been adjusted at an ambient

temperature between +20°C and +30°C, has had a warm-up period of at least 20 minutes, and is operating at an ambient temperature between -10°C and +55°C (unless otherwise noted).

Specifications for non-counter/timer functions with digital readout are valid only when the ambient temperature is within $\pm 10^\circ\text{C}$ of the temperature at the time of the last SELF CAL. For maximum performance, a recent SELF CAL is recommended.

Items listed in the Performance Requirements column are verifiable qualitative or quantitative limits that define the measurement capabilities of the instrument.



Environmental characteristics are given in Table 1-2, and mechanical characteristics of the instrument are listed in Table 1-3.

Table 1-1
Electrical Characteristics

CHARACTERISTICS	PERFORMANCE REQUIREMENTS				
VERTICAL DEFLECTION SYSTEM – CH 1 AND CH 2					
Deflection Factor					
Range	2 mV/div to 5 V/div in 1-2-5 sequence. ^a				
Accuracy (includes ADD MODE and CH 2 INVERT)					
15°C to 35°C	±2%.				
-10°C to 15°C and 35°C to 55°C	±3%. ^a				
Variable Range	Increases deflection factor by at least 2.5:1.				
Frequency Response (-3 dB bandwidth)					
-10°C to 35°C					
5 mV to 5 V/div	Dc to 100 MHz (at the input BNC and at the probe tip).				
2 mV	Dc to 90 MHz (at the input BNC and at the probe tip).				
35°C to 55°C	Dc to 90 MHz (at the input BNC and at the probe tip). ^a				
AC Coupled Lower -3 dB Point					
1X Probe	10 Hz or less.				
10X Probe	1 Hz or less.				
Step Response (5-division step)					
Rise Time					
-10°C to 35°C					
5 mV to 5 V/div	3.5 ns or less (calculated). ^a				
2 mV/div	3.9 ns or less (calculated). ^a				
35°C to 55°C	3.9 ns or less (calculated). ^a				
Delay Match (CH 1 to CH 2)	Less than 200 ps difference.				
Common Mode Rejection Ratio (CMRR)	At least 10:1 at 50 MHz for signals of eight division or less with VOLTS/DIV VAR adjusted for best CMRR at 50 kHz.				
Channel Isolation (attenuation of deselected channel)					
2 mV/div to 0.5 V/div	<table border="1" style="margin-left: auto; margin-right: auto;"> <thead> <tr> <th align="center">10 MHz</th> <th align="center">100 MHz</th> </tr> </thead> <tbody> <tr> <td align="center">50 dB or more</td> <td align="center">34 dB or more</td> </tr> </tbody> </table> <p align="center">Channel isolation tested with eight-division input signal.</p>	10 MHz	100 MHz	50 dB or more	34 dB or more
10 MHz	100 MHz				
50 dB or more	34 dB or more				
Trace Shift as VAR VOLTS/DIV is Turned	1 division or less.				

^a Performance Requirement not checked in manual.

Table 1-1 (cont)

CHARACTERISTICS	PERFORMANCE REQUIREMENTS
Invert Trace Shift	1 division or less.
Trace Shift Between VOLTS/DIV Switch Positions	0.2 division or less.
Trace Shift Between GND and DC Input Coupling	
-10°C to 35°C	Less than 0.5 mV.
35°C to 55°C	Less than 2 mV. ^a
Input Characteristics	
Resistance	1 MΩ ±1.0%. ^a
Capacitance	20 pF ±1 pF. ^a
Capacitance Match Between Any Two VOLTS/DIV Settings	±0.5 pF. ^a
Maximum Input Volts 	400 V (dc + peak ac); 800 V p-p at 10 kHz or less. ^a (See Figure 1-1.)
VERTICAL DEFLECTION SYSTEM – CH 3 AND CH 4	
Deflection Factor	
Range	0.1 V per division and 0.5 V per division.
Accuracy	
15°C to 35°C	±2%.
-10°C to 55°C	±3%. ^a
Frequency Response (-3 dB bandwidth)	
-10°C to 35°C	Dc to 100 MHz (at the input BNC and at the probe tip).
35°C to 55°C	Dc to 90 MHz (at the input BNC and at the probe tip). ^a
Step Response (5-division step)	
Rise Time	
-10°C to 35°C	3.5 ns or less (calculated). ^a
35°C to 55°C	3.9 ns or less (calculated). ^a
Delay Match (CH 3 to CH 4)	Less than 200 ps difference.
Trace Shift Between VOLTS/DIV Settings	1 division or less.
Channel Isolation (attenuation of deselected channel)	34 dB or more at 100 MHz. Channel isolation tested with eight-division input signal.
Input Characteristics	
Resistance	1 MΩ ±1.0%. ^a
Capacitance	20 pF ±1 pF. ^a
Maximum Input Volts 	400 V (dc + peak ac); 800 V p-p at 10 kHz or less. ^a (See Figure 1-1.)

^a Performance Requirement not checked in manual.

Table 1-1 (cont)

CHARACTERISTICS	PERFORMANCE REQUIREMENTS						
VERTICAL DEFLECTION SYSTEM – ALL CHANNELS							
Bandwidth Limit (-3 dB bandwidth)	20 MHz \pm 15%.						
Low-Frequency Linearity (relative to center screen)	\pm 5%. Linearity is measured by positioning a two-division test signal anywhere on screen and noting the amplitude change.						
Position Range	At least \pm 11 divisions from graticule center.						
TRACE SEP Control Position Range	At least \pm 4 divisions.						
CHOP Mode Clock Rate	625 kHz \pm 10%. ^a						
Delay Match (CH 1 or CH 2 to CH 3 or CH 4)	Less than 200 ps difference.						
HORIZONTAL DEFLECTION SYSTEM							
Sweep Range							
A Sweep	0.5 s/div to 20 ns/div in a 1-2-5 sequence. ^a X10 magnifier extends maximum sweep speed to 2 ns/div.						
B Sweep	5.0 ms/div to 20 ns/div in a 1-2-5 sequence. ^a X10 magnifier extends maximum sweep speed to 2 ns/div.						
Accuracy							
15°C to 35°C	<table border="1" style="margin-left: auto; margin-right: auto;"> <thead> <tr> <th>Unmagnified</th> <th>Magnified</th> </tr> </thead> <tbody> <tr> <td style="text-align: center;">\pm2%</td> <td style="text-align: center;">\pm3%</td> </tr> <tr> <td style="text-align: center;">\pm3%^a</td> <td style="text-align: center;">\pm4%^a</td> </tr> </tbody> </table>	Unmagnified	Magnified	\pm 2%	\pm 3%	\pm 3% ^a	\pm 4% ^a
Unmagnified	Magnified						
\pm 2%	\pm 3%						
\pm 3% ^a	\pm 4% ^a						
-10°C to 15°C and 35°C to 55°C	\pm 3% ^a \pm 4% ^a						
	Sweep Accuracy applies over the center eight divisions. Excludes the first 1/4 division or 25 ns from the start of the magnified sweep and anything beyond the 100th magnified division.						
Sweep Linearity (relative to center two displayed divisions)	\pm 5%. Sweep Linearity applies over the center eight divisions. Excludes the first 1/4 division or 25 ns from the start of the magnified sweep and anything beyond the 100th magnified division.						
POSITION Control Range							
Normal Displays	Able to move the start of the sweep to the right of the center vertical graticule; able to move a time mark corresponding to the end of the tenth division of an unmagnified sweep to the left of the center graticule.						
X-Y Displays	At least \pm 13 divisions. ^a						
X10 Magnifier	Expands the normal sweep by ten times around that portion of the sweep positioned at the center vertical graticule line. ^a						
Registration (X10 to X1)	0.5 division or less shift.						

^a Performance Requirement not checked in manual.

Table 1-1 (cont)

CHARACTERISTICS	PERFORMANCE REQUIREMENTS
Variable Control Range	Continuously variable between calibrated SEC/DIV settings. Extends both the A and B sweep time per division by at least a factor of 2.5.
Sweep Length	Greater than 10 divisions.
Delay Time	
Delay Control Range	Less than 0.1 division to 10 times the A SEC/DIV switch setting. Maximum value does not exceed end of the A Sweep.
Delay Accuracy, A Sweep Trigger Point to Start of B Sweep	$\pm (0.5\% \text{ of reading} + 5\% \text{ of 1 division of the A Sweep} + 25 \text{ ns})$.
Jitter	1 part in 20,000, or less, peak-to-peak, during a two-second time interval.
Delta Time	
Delta Control Range	0 to greater than 9.9 divisions to the right of setting of DELAY control, but maximum value does not exceed end of the A Sweep.
A AND B TRIGGER	
Sensitivity – CH 1 through CH 4; AUTO LEVEL, AUTO, NORM, and SGL SEQ	Trigger sensitivity is defined as the minimum peak-to-peak sine-wave trigger signal amplitude required to show the test signal with horizontal jitter of less than 3.0% of one period (p-p viewed over two seconds), with Trigger LEVEL control set at midlevel, but not at control extremes.
COUPLING	
DC	0.35 division from dc to 25 MHz, increasing to 1.0 division at 150 MHz (100 MHz in AUTO LEVEL).
NOISE REJECT	1.4 division from dc to 25 MHz; increasing to 2.2 divisions at 100 MHz. 0.5 division or less will not trigger.
HF REJECT	0.35 division from dc to 50 kHz; attenuates signals above upper -3 dB cutoff frequency of 70 kHz.
LF REJECT	0.35 division from 100 kHz to 25 MHz, increasing to 1.0 division at 150 MHz (100 MHz in AUTO LEVEL); attenuates signals below the lower -3 dB cutoff frequency of 50 kHz.
AC	0.35 division from 50 Hz to 25 MHz, increasing to 1.0 division at 150 MHz; (100 MHz in AUTO LEVEL); attenuates signals below the lower -3 dB cutoff frequency of 20 Hz.
TV LINE, TV FIELD	0.5 division of composite sync will achieve a stable display.
Channel Isolation (attenuation of deselected channel)	
CH 1 or CH 2 to Any Other Channel	20 dB or more at 100 MHz. ^a
CH 3 or CH 4 to Any Other Channel	30 dB or more at 100 MHz. ^a

^a Performance Requirement not checked in manual.

Table 1-1 (cont)

CHARACTERISTICS	PERFORMANCE REQUIREMENTS
Free Run Enable Frequency AUTO and AUTO LEVEL	The sweep will free run if trigger source frequency is less than 10 Hz. ^a In AUTO LEVEL, if the trigger-source frequency is ≤ 25 Hz, the range of the Trigger LEVEL control may be reduced.
LEVEL Control Range AUTO, NORM, and SGL SEQ	± 20 divisions referred to the appropriate vertical input. This range is sufficient to allow triggering at any point on a displayed waveform for all modes except ADD. In ADD, the combined range of the two position controls exceeds the trigger level range, making it possible (though unlikely) to pull a signal on screen for display but fail to trigger on it due to insufficient trigger level range.
AUTO LEVEL	Does not exceed the peak-to-peak amplitude of the trigger signal that was present when the AUTO LEVEL limits were set. ^a
TRIGGER LEVEL READOUT Accuracy	$\pm (0.3\% \text{ of reading} + 10\% \text{ of one vertical division}).^a$
HOLDOFF Control Range	Increases A Sweep holdoff time by at least a factor of 10. ^a

VOLTMETER AND CURSOR FUNCTIONS

VOLTMETER FUNCTIONS	
DC VOLTS	
Accuracy	$\pm (0.5\% \text{ of reading} + 2\% \text{ of one vertical division} + 250 \mu\text{V}).$
Normal Mode Rejection Ratio	Greater than 50 dB at 50 or 60 Hz.
PLUS or MINUS Peak	
Accuracy – Full Bandwidth	
25 Hz to 25 MHz	$\pm (2.0\% \text{ of reading} + 15\% \text{ of one vertical division} + 1 \text{ mV}).$
Greater Than 25 MHz to 100 MHz (90 MHz at 35°C to 55°C)	+ 0.5 dB, -3 dB ± 1 mV. Follows the trigger system frequency response curve.
Accuracy – Bandwidth Limited (25 Hz to 10 MHz)	$\pm (2.0\% \text{ of reading} + 10\% \text{ of one vertical division} + 0.3 \text{ mV}).$
Gated Region Minimum Width (when gated)	(0.2 division + 50 ns) or less.

^a Performance Requirement not checked in manual.

Table 1-1 (cont)

CHARACTERISTICS	PERFORMANCE REQUIREMENTS
VOLTMETER FUNCTIONS (cont)	
PK-PK VOLTS	
Accuracy – Full Bandwidth	
25 Hz to 25 MHz	±(2.0% of reading + 15% of one vertical division + 1.5 mV).
Greater Than 25 MHz to 100 MHz (90 MHz at 35°C to 55°C)	+0.5 dB, -3 dB ±1.5 mV. Follows the trigger system frequency response curve.
Accuracy – Bandwidth Limited	
25 Hz to 10 MHz	±(2.0% of reading + 10% of one vertical division + 0.5 mV).
Gated Region Minimum Width (when gated)	(0.2 division + 50 ns) or less.
CURSOR FUNCTIONS	
← SEC → (manually positioned cursors)	
Accuracy	
A Horizontal Mode	±(0.5% of reading + 2% of one horizontal division).
B Horizontal Mode	±(3.0% of reading + 2% of one horizontal division).
← 1/SEC → (manually positioned cursors)	
Accuracy	Readout calculated from ← SEC → cursor positions.
← VOLTS → (manually positioned cursors)	
Accuracy	±(0.5% of reading + 2% of one vertical division + high-frequency display errors).
↗ VOLTS → (manually positioned cursor)	
Accuracy	±(0.5% of reading + 2% of one vertical division + high-frequency display errors).
← PHASE → (manually positioned cursors)	
Accuracy	Readout calculated from ← SEC → cursor positions.
TRACK MEASUREMENT	
Position Accuracy (cursor position on waveform versus digitally displayed measurement value)	±0.05 vertical division.
TRACK TRIG LEVEL	
Position Accuracy (cursor position on waveform versus digitally displayed trigger level value)	±0.05 vertical division.

Table 1-1 (cont)

CHARACTERISTICS	PERFORMANCE REQUIREMENTS
CURSOR FUNCTIONS (cont)	
TRACK GROUND Position Accuracy (cursor position on waveform versus baseline displayed with grounded input)	±0.05 vertical division.
Delay Accuracy, A Sweep Trigger Point to Start of B Sweep	± (0.5% of reading + 5.0% of one division of the A Sweep + 25 ns).
COUNTER/TIMER (C/T) (see formula definitions at end of this section)	
Time Base	
Frequency ^a	200 MHz.
Internal Oscillator	
Short-term error ^a	
+15°C to +35°C	±1 × 10 ⁻⁵ (10 ppm).
-10°C to +15°C and +35°C to +55°C	±5 × 10 ⁻⁵ (50 ppm).
Long-term drift ^a	Less than 2 ppm change per year.
External Oscillator	C/T automatically senses the applied external input signal, determines whether it is 1, 5, or 10 MHz (each can be ±2%), and multiplies it by 200, 40, or 20 respectively to derive the 200 MHz timing signal. Indication is given in readout when external timebase is being used.
Frequency	
Range	
C/T TRIG TIMEOUT Enabled, or B Trigger MODE in AUTO LEVEL ^a	Less than 4 Hz to greater than 100 MHz.
C/T TRIG TIMEOUT Disabled, and B Trigger MODE not in AUTO LEVEL ^a	0.01 Hz to greater than 100 MHz. Displays "< 0.01 Hz" if underranged.
Non-gated Mode	
Resolution (Hz) ^a	± $\frac{1.4 \times TJE \times F^2}{N}$ ± LSD
Accuracy (Hz)	Resolution ±(F × TBE)

^a Performance Requirement not checked in manual.

Table 1-1 (cont)

CHARACTERISTICS	PERFORMANCE REQUIREMENTS
Frequency (cont)	
Gated Mode	
Resolution (Hz) ^a	$\pm \frac{1.4 \times TJE \times F^2}{N_g \times \sqrt{G}} \pm \text{LSD}$
Freq Gating Error (Hz) ^a	$\frac{0.5 \text{ ns}}{N_g} \times F^2$
Accuracy (Hz)	Resolution $\pm (F \times \text{TBE}) \pm \text{freq gating error}$.
LSD (Hz) ^a	$\frac{F^2}{N \times 2 \times 10^8}$ No more than 8 digits displayed; minimum LSD displayed is 10 nHz (10 ⁻⁹ Hz).
Period	
Range	
C/T TRIG TIMEOUT Enabled, or B Trigger MODE in AUTO LEVEL ^a	Greater than 250 ms to less than 10 ns.
C/T TRIG TIMEOUT Disabled, and B Trigger MODE not in AUTO LEVEL ^a	100 s to less than 10 ns. Displays "> 100s" if overranged.
Non-gated Mode	
Resolution (seconds) ^a	$\pm \frac{1.4 \times TJE}{N} \pm \text{LSD}$
Accuracy (seconds)	Resolution $\pm (P \times \text{TBE})$.
Gated Mode	
Resolution (seconds) ^a	$\pm \frac{1.4 \times TJE}{N_g \times \sqrt{G}} \pm \text{LSD}$
Time Interval Gating Error (seconds) ^a	$\frac{0.5 \text{ ns}}{N_g}$
Accuracy (seconds)	Resolution $\pm (P \times \text{TBE}) \pm \text{time interval gating error}$.
LSD (seconds) ^a	$\frac{5 \text{ ns}}{N}$ No more than 8 digits displayed; minimum LSD displayed is 100 attosec.
Width	
Range	
C/T TRIG TIMEOUT Enabled, or B Trigger MODE in AUTO LEVEL ^a	Greater than 250 ms to less than 5 ns.
C/T TRIG TIMEOUT Disabled, and B Trigger MODE not in AUTO LEVEL ^a	100 s to less than 5 ns. Displays "> 100s" if overranged.

^a Performance Requirement not checked in manual.

Table 1-1 (cont)

CHARACTERISTICS	PERFORMANCE REQUIREMENTS
Width (cont) Non-gated Mode Resolution (seconds) ^a	$\pm \frac{1}{\sqrt{N}} \times \text{TJE at start point}$ $\pm \frac{1}{\sqrt{N}} \times \text{TJE at stop point}$ $\pm \text{LSD}$
Accuracy (seconds)	Resolution $\pm(W \times \text{TBE})$ \pm hysteresis error \pm start point slew error \pm stop point slew error ± 2 ns.
Gated Mode Resolution (seconds) ^a	$\pm \frac{1}{\sqrt{N_g} \times G} \times \text{TJE at start point}$ $\pm \frac{1}{\sqrt{N_g} \times G} \times \text{TJE at stop point}$ $\pm \text{LSD}$
Accuracy (seconds)	Resolution $\pm(W \times \text{TBE})$ \pm hysteresis error \pm time interval gating error \pm start point slew error \pm stop point slew error ± 2 ns.
Hysteresis Error (seconds) ^a	$\frac{\text{HYS}}{\text{slew rate of stop edge at trigger point (div/sec)}}$
Start Point Slew Error (seconds) ^a	$\frac{\text{TLE}}{\text{slew rate of start edge at trigger point (div/sec)}}$
Stop Point Slew Error (seconds) ^a	$\frac{\text{TLE}}{\text{slew rate of stop edge at trigger point (div/sec)}}$
LSD (seconds) ^a	$\frac{5 \text{ ns}}{\sqrt{N}}$ <p>No more than 8 digits displayed; minimum LSD displayed is 1 picosec.</p>

^a Performance Requirement not checked in manual.

Table 1-1 (cont)

CHARACTERISTICS	PERFORMANCE REQUIREMENTS
Totalize Range ^a	0 to 999999999. Displays "> 999999999" on overrange.
Gated Events Range ^a	0.000001 to 999999999.0 Displays "> 999999999" on overrange.
Resolution, When Gate Is Synchronous to B Trigger Signal ^a	LSD
Resolution, When Gate Is Not Synchronous to B Trigger Signal ^a	$\frac{1}{\sqrt{G}} + \text{LSD}$
LSD ^a	$\frac{1}{G}$ No more than 10 digits displayed.
Accuracy	Same as resolution.
Frequency Ratio Range ^a	.00000001 to 99999999 Displays "> 99999999" on overrange.
Resolution ^a	$\pm R \times \frac{1.4 \times \text{TJE}_1 \times F_1}{N_1}$ $\pm R \times \frac{1.4 \times \text{TJE}_2 \times F_2}{N_2} \pm \text{LSD}$
LSD ^a	$\frac{R}{2 \times 10^8} \times \left(\frac{F_1}{N_1} + \frac{F_2}{N_2} \right)$ No more than 8 digits displayed; minimum LSD displayed is .00000001.
Accuracy	Resolution $\pm (R \times \text{TBE})$.

^a Performance Requirement not checked in manual.

Table 1-1 (cont)

CHARACTERISTICS	PERFORMANCE REQUIREMENTS
Delta Time (← SEC →) (ΔT)	C/T is used when horizontal mode is ALT. C/T may also be used when horizontal mode is B.
Range ^a	0 to greater than ± 5 s.
B Runs After Delay Mode Accuracy (seconds) ^a	$\pm 1.0\%$ of one division of A sweep.
B Triggered After Delay Mode Resolution (seconds) ^a	$\pm \frac{1}{\sqrt{N_d}} \times \text{TJE at start point}$ $\pm \frac{1}{\sqrt{N_d}} \times \text{TJE at stop point}$ $\pm \text{LSD}$
LSD (seconds) ^a	$\frac{5 \text{ ns}}{\sqrt{N_d}}$ No more than 8 digits displayed; minimum LSD displayed is 1 picosec (10^{-12} s).
Accuracy (seconds)	Resolution $\pm (T \times \text{TBE})$ \pm channel delay mismatch ^b \pm start point slew error \pm stop point slew error ± 100 ps.
One-Over-Delta Time ($1/\Delta T$) (← 1/SEC →)	C/T is used when horizontal mode is ALT. C/T may also be used when horizontal mode is B.
Range ^a	Less than 0.2 Hz to 10 GHz. Displays "> 10GHz" on overrange.
B Triggered After Delay Mode Resolution (Hz) ^a	$\pm F_e^2 \times (\text{delta-time resolution})$
Accuracy (Hz)	$\pm F_e^2 \times (\text{delta-time resolution})$
Phase A Horizontal Mode ^a	When 360° tracking is on, the C/T measures the A trig period and uses this result for the 360° reference. When 360° tracking is off, the measurement uses the fixed reference value obtained with the ← SET 360° → function.
ALT or B Modes Range ^a	C/T is used to measure the time interval when horizontal mode is ALT. C/T may also be used when horizontal mode is B. 0 to ± 99999999 degrees. Displays "> 99999999°" on overrange.

^a Performance Requirement not checked in manual.

^b Channel delay mismatch is zero when start and stop points are on same channel.

Table 1-1 (cont)

CHARACTERISTICS	PERFORMANCE REQUIREMENTS
Phase (cont)	
ALT or B Modes (cont)	
B Triggered After Delay	
360 Degree Tracking Off	
Resolution (in degrees) ^a	$\pm \frac{360 \times (\text{delta-time resolution})}{(360 \text{ degree reference time})}$
Accuracy (in degrees)	$\pm \frac{360 \times (\text{delta-time accuracy})}{(360 \text{ degree reference time})}$
360 Degree Tracking On	
Resolution (in degrees) ^a	$\pm 360 \times \left[\frac{1.4 \times TJE_a}{N_a} \pm (\text{delta-time resolution}) \right]$
Accuracy (in degrees)	$\pm 360 \times \left[\frac{1.4 \times TJE_a}{N_a} \pm (\text{delta-time accuracy}) \right]$
Rise/Fall	When measurement is first selected, or measurement is not in SET REF mode when reselected, the + and – peaks of the signal are measured. Then, the trigger levels are set and the rise/fall time measurement proceeds.
Minimum Signal Amplitude for Successful Autotriggering ^a	4.0 divisions.
Minimum Signal Frequency for Successful Autotriggering ^a	25 Hz. If signal frequency is less than minimum, SET REF mode can be used to manually set trigger levels.
Trigger Level Setting Error (after autotriggering) ^a	Peak measurement error + trigger level readout error (in divisions; see A AND B TRIGGER and VOLTMETER FUNCTIONS PK-PK VOLTS).
Trigger Level Setting Error (when SET REF mode is used) ^a	Trigger level readout error in divisions; rise/fall time accuracy is specified with respect to the trigger levels selected by the user via SET REF mode, rather than the 10% and 90% points on the signal being measured.
Range ^a	0 to greater than 5 seconds.
Resolution ^a	$\pm \frac{1}{\sqrt{N_t}} \times TJE \text{ at start point}$ $\pm \frac{1}{\sqrt{N_t}} \times TJE \text{ at stop point}$ $\pm \text{LSD}$

^a Performance Requirement not checked in manual.

Table 1-1 (cont)

CHARACTERISTICS	PERFORMANCE REQUIREMENTS
Rise/Fall (cont) LSD (seconds) ^a	$\pm \frac{5 \text{ ns}}{\sqrt{N_t}}$ No more than 8 digits displayed; minimum LSD displayed is 1 picosec.
Accuracy	Resolution $\pm(T \times \text{TBE})$ \pm start point slew error \pm stop point slew error $\pm 2 \text{ ns}$.
Start Point Slew Error ^a	$\frac{\text{Trigger level setting error}}{\text{Slew rate of signal at start point (div/sec)}}$
Stop Point Slew Error ^a	$\frac{\text{Trigger level setting error}}{\text{Slew rate of signal at stop point (div/sec)}}$
Propagation Delay	
Range ^a	0 to greater than ± 5 seconds.
Resolution ^a	$\pm \frac{1}{\sqrt{N_{pd}}} \times \text{TJE at start point}$ $\pm \frac{1}{\sqrt{N_{pd}}} \times \text{TJE at stop point}$ $\pm \text{LSD}$
LSD (seconds) ^a	$\pm \frac{5 \text{ ns}}{\sqrt{N_{pd}}}$ No more than 8 digits displayed; minimum LSD displayed is 1 picosec (10^{-12} s).
Accuracy	Resolution $\pm(T \times \text{TBE})$ \pm channel delay mismatch ^c \pm start point slew error \pm stop point slew error $\pm 100 \text{ ps}$.

^a Performance Requirement not checked in manual.^c Delay mismatch between input channels can be nulled out with SET ZERO REF.

Table 1-1 (cont)

CHARACTERISTICS	PERFORMANCE REQUIREMENTS													
Trigger Jitter Error (TJE) in seconds ^a	$\frac{\sqrt{(e_1)^2 + (e_2)^2}}{\text{Slew rate of triggering edge (div/sec)}}$													
	Value of e_1 = RMS noise in signal applied at input BNC (in divisions).													
	Value of e_2 (in divisions RMS) ^a													
	2 mV per division	<table border="1" style="margin-left: auto; margin-right: auto;"> <thead> <tr> <th style="text-align: center;">BWL on</th> <th style="text-align: center;">BWL off</th> </tr> </thead> <tbody> <tr> <td style="text-align: center;">0.13</td> <td style="text-align: center;">0.33</td> </tr> <tr> <td style="text-align: center;">0.08</td> <td style="text-align: center;">0.16</td> </tr> <tr> <td style="text-align: center;">0.06</td> <td style="text-align: center;">0.11</td> </tr> <tr> <td style="text-align: center;">0.05</td> <td style="text-align: center;">0.08</td> </tr> <tr> <td style="text-align: center;">0.04</td> <td style="text-align: center;">0.07</td> </tr> </tbody> </table>	BWL on	BWL off	0.13	0.33	0.08	0.16	0.06	0.11	0.05	0.08	0.04	0.07
	BWL on	BWL off												
	0.13	0.33												
0.08	0.16													
0.06	0.11													
0.05	0.08													
0.04	0.07													
5 mV per division	0.08 0.16													
10 mV per division	0.06 0.11													
20 mV per division	0.05 0.08													
50 mV per division or higher	0.04 0.07													

COUNTER/TIMER DEFINITIONS

- F = Frequency of input, in Hz.
- F_e = Equivalent frequency (1/T).
- F₁ = Frequency 1.
- F₂ = Frequency 2.
- HYS = B trigger sensitivity, in divisions (see A and B TRIGGER).
- LSD = Least significant digit.
- N = Number of input events averaged.
 For non-gated mode, N = F × (0.320 ± 0.010 s)
 For gated mode, N = N_g × G
 (N is always ≥ 1)
- G = Number of gate intervals in one measurement.
 = (gate signal repetition rate) × (GATETIME ± 0.010 s) ≥ 1
 GATETIME = 0.320 s in AUTO RESOLUTION mode. When a resolution magnifier is used, the gate time increases as needed to obtain the extra resolution.
- N_a = Number of A trigger periods averaged.
 = (A trigger frequency) × (0.320 ± 0.010 s)
 (N is always ≥ 1)
- N_d = Number of delta-time intervals averaged in one measurement.
 = $\frac{(\text{A sweep repetition rate}) \times (\text{GATETIME} \pm 0.010 \text{ s})}{\text{Number of sweeps in one display sequence}}$
 GATETIME = 0.603 sec in AUTO RESOLUTION mode. When a resolution magnifier is used, the gate time increases as needed to obtain the extra resolution.
 Number of sweeps is found by counting number of channels displayed; each channel with one intensified zone gets counted twice; if one channel has both zones, this channel gets counted 4 times.

^a Performance Requirement not checked in manual.

Table 1-1 (cont)

COUNTER/TIMER DEFINITIONS (cont)

N_g = Number of trigger events inside one gate interval ≥ 1 .

N_{pd} = Number of prop delay intervals averaged in one measurement.

$$= \frac{(\text{A sweep repetition rate}) \times (\text{GATETIME} \pm 0.010 \text{ s})}{\text{Number of sweeps in one display sequence}}$$

GATETIME = 0.603 sec in AUTO RESOLUTION mode. When a resolution magnifier is used, the gate time increases as needed to obtain the extra resolution.

Number of sweeps is found by counting number of channels displayed; if both START and STOP trigger are on one channel, this channel gets counted twice.

N_t = Number of transition time intervals (rise or fall) averaged in one measurement.

$$= \frac{(\text{A sweep repetition rate}) \times (\text{GATETIME} \pm 0.010 \text{ s})}{\text{Number of sweeps in one display sequence}}$$

GATETIME = 0.603 sec in AUTO RESOLUTION mode. When a resolution magnifier is used, the gate time increases as needed to obtain the extra resolution.

Number of sweeps is found by counting number of channels displayed; the channel being measured gets counted twice.

N_1 = Number of F_1 periods averaged.

N_2 = Number of F_2 periods averaged.

P = Period of input, in seconds.

R = Ratio, F_1/F_2 .

T = Time interval being measured.

TBE = Total timebase error.

TJE = Trigger jitter error at trigger point.

TJE_1 = Trigger jitter error associated with F_1 .

TJE_2 = Trigger jitter error associated with F_2 .

TJE_a = Trigger jitter error of A trigger period measurement.

TLE = B trigger level readout error, in divisions (see A and B TRIGGER).

W = Width of input, in seconds.

Table 1-1 (cont)

CHARACTERISTICS	PERFORMANCE REQUIREMENTS
X-Y OPERATION	
Deflection Factors	Same as Vertical deflection system with the VOLTS/DIV variable controls in calibrated detent position. ^a
Accuracy	
X Axis	
15°C to 35°C	±3%.
-10°C to 15°C and 35°C to 55°C	±4%. ^a
Horizontal (X-Axis) -3 dB Bandwidth	3 MHz or more.
Phase Match (DC Coupled)	± 3 degrees from dc to 50 kHz.
EXTERNAL Z-AXIS INPUT	
Active Region Lower Threshold (intensity decreases above this voltage)	+ 1.8 volts or less.
Signal Required to Modulate an A or B Trace	+ 3.8 volts or less provides noticeable modulation of a normal intensity trace. Usable frequency range is dc to 10 MHz. External Z-Axis signal does not affect the readout or the intensified zone intensity.
Maximum Input Voltage 	30 V (dc + peak ac); 30 V p-p ac at 1 kHz or less. ^a
Input Loading	Represents less than one LSTTL load. ^a
EXTERNAL C/T REFERENCE INPUT	
Input Impedance	10.1 kΩ ±5%, AC coupled. ^a
Sensitivity	1 volt pk-pk, duty factor from 40% to 60% measured at the DC average point on the waveform.
Maximum Input Voltage	35 volts (dc + peak ac). ^a
Allowable Input Frequencies	1, 5, or 10 MHz ±2%. Counter/Timer automatically senses the applied external input signal, determines whether it is 1, 5, or 10 MHz, and multiplies it by 200, 40, or 20 respectively to derive the 200 MHz timing signal. Indication is given in readout when external timebase is being used.
PROBE ADJUST OUTPUT	
Overshoot (rising and falling edge)	0.1% or less.
Output Voltage on PROBE ADJUST Jack	0.5 V ±2% into 1 MΩ load.
Repetition Rate	1 kHz ±25%.

^a Performance Requirement not checked in manual.

Table 1-1 (cont)

CHARACTERISTICS	PERFORMANCE REQUIREMENTS
FRONT PANEL SETUP MEMORY	
Battery Life	5 years. ^a
Battery Type	3.0 V, 1200 mA _H , Type BR-2/3AE2P, Lithium. ^a WARNING – To avoid personal injury, have battery replaced only by a qualified service person who understands proper handling and disposal procedures for Lithium batteries.
POWER SOURCE	
Line Voltage Range	90 Vac to 250 Vac. ^a
Line Frequency	48 Hz to 445 Hz. ^a
Line Fuse	2 A, 250 V, slow blow. ^a
Maximum Power Consumption	100 Watts (155 VA). ^a
CRT DISPLAY	
Display Area	8 by 10 cm. ^a
Geometry	
Vertical	±1/2 minor (0.1 div) at 8 by 8 cm centered area.
Horizontal	±1/2 minor (0.1 div) at 8 by 10 cm centered area.
Trace Rotation Range	Adequate to align trace with center horizontal graticule line.
Standard Phosphor	P31. ^a
Y-Axis Orthogonality	0.1 division or less, over eight vertical divisions. No adjustment.
Nominal Accelerating Voltage	16 kV. ^a

^a Performance Requirement not checked in manual.

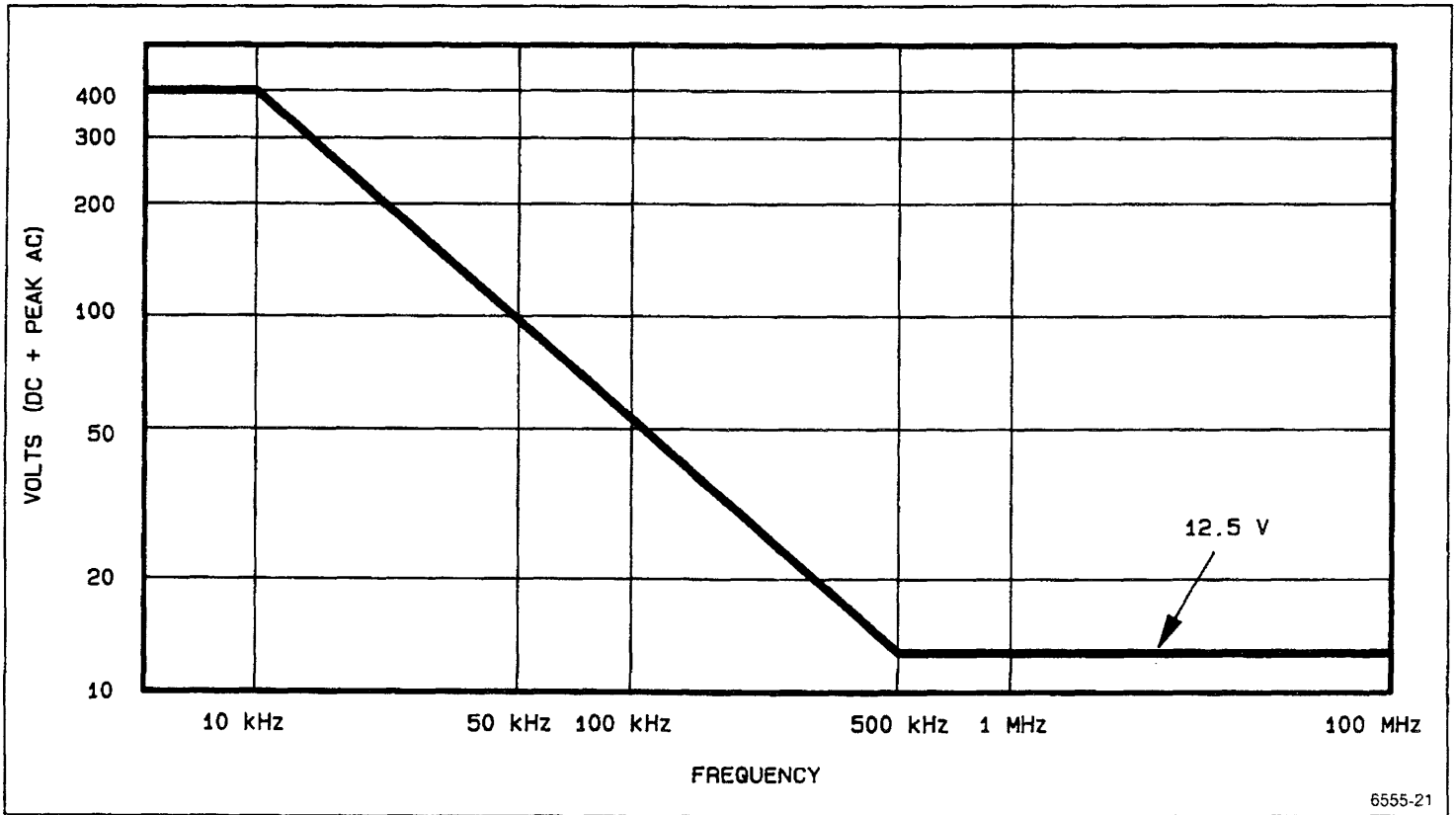

Figure 1-1. Maximum input voltage vs frequency derating curve for the CH 1, CH 2, CH 3, or CH 4 input connector.

**Table 1-2
Environmental Characteristics**

CHARACTERISTICS	DESCRIPTION
STANDARD INSTRUMENT	
Environmental Requirements	Instrument meets or exceeds the environmental requirements of MIL-T-28800D for Type III, Class 3, Style D equipment, as described below. ^a
Temperature	
Operating	-10°C to +55°C (+14°F to +131°F).
Nonoperating	-51°C to +71°C (-60°F to +160°F). Tested to MIL-T-28800D paragraphs 4.5.5.1.3 and 4.5.5.1.4, except in 4.5.5.1.3, steps 4 and 5 (-10°C operating test) are performed ahead of step 2 (-51°C non-operating test). Equipment shall remain off upon return to room ambient during step 6. Excessive condensation shall be removed before operating during step 7.
Altitude	
Operating	To 4,570 m (15,000 ft). Maximum operating temperature decreases 1°C per 1,000 ft above 5,000 ft.
Nonoperating	To 15,240 m (50,000 ft).
Humidity (operating and nonoperating)	Five cycles (120 hours) referenced to MIL-T-28800D paragraph 4.5.5.1.2.2, for Type III, Class 3 instruments. Nonoperating and operating at 95%, -0% to +2% relative humidity. Operating at +30°C and +55°C for all modes of operation. Nonoperating at +30°C to +60°C.
Radiated and Conducted Emission Required per VDE 0871	Meets Category B.
Electrostatic Discharge	Withstands discharge of up to 20 kV. Test performed with probe containing a 500 pF capacitor with 1 kΩ resistance charged to the test voltage. Conforms to Tektronix Standard 062-2862-00.
Vibration (operating)	15 minutes along each of 3 major axes at a total displacement of 0.025 inch p-p (4 g at 55 Hz) with frequency varied from 10 Hz to 55 Hz in 1-minute sweeps. Hold for 10 minutes at 55 Hz in each of the three major axes. All major resonances must be above 55 Hz.
Bench Handling Test (cabinet on and cabinet off)	MIL-STD-810D, Method 516.3, Procedure VI (MIL-T-28800D, Paragraph 4.5.5.4.3).
Transportation	
Packaged Vibration Test	Meets the limits of the National Safe Transit Association test procedure 1A-B-1; excursion of 1 inch p-p at 4.63 Hz (1.1 g) for 30 minutes on the bottom and 30 minutes on the side (for a total of 60 minutes).
Package Drop Test	Meets the limits of the National Safe Transit Association test procedure 1A-B-2; 10 drops of 36 inches.

^a Performance requirement not checked in manual.

**Table 1-3
Mechanical Characteristics**

CHARACTERISTICS	DESCRIPTION
STANDARD INSTRUMENT	
Weight	
With Front Cover, Accessories, and Accessories Pouch (without manual)	8.9 kg (19.5 lb).
With Power Cord	7.9 kg (17.3 lb).
Shipping Weight (domestic)	11.7 kg (25.8 lb).
Overall Dimensions	See Figure 1-2, dimensional drawing.
Height	
With Feet and Accessories Pouch (empty)	Approx. 176.5 mm (6.95 in).
Without Accessories Pouch	164 mm (6.44 in).
Width (with handle)	362 mm (14.25 in).
Depth	
With Front Cover On	445.3 mm (17.53 in).
With Handle Extended	521 mm (20.53 in).
Cooling	Forced air circulation; no air filter.
Finish	Tek Blue, finish painted on pebble-grain aluminum cabinet.
Construction	Aluminum alloy chassis. Plastic-laminate front panel.
RACKMOUNTED INSTRUMENT	
Weight	
With Power Cord	10.0 kg (22.0 lb).
Shipping Weight	
Domestic (includes manual)	14.2 kg (31.3 lb).
Overall Dimensions	See Figure 1-3, dimensional drawing.
Height	
Overall	168 mm (6.6 in).
Center of Mounting Rail to Bottom of Cabinet	89 mm (3.5 in).
From Cabinet Top or Bottom to Respective Front Panel Mounting Holes	38 mm (1.5 in).
Between Front Panel Mounting Holes	102 mm (4.0 in).

Table 1-3 (cont)

CHARACTERISTICS	DESCRIPTION
Overall Dimensions (cont)	
Width	
Overall	483 mm (19.0 in).
Between Mounting Hole Centers	464 mm (18.3 in).
Between Outer Edges of Mounting Rails	427 mm (16.8 in).
Between Handle Centers	450 mm (17.7 in).
Depth	
Overall	516 mm (20.35 in).
Front Panel to Rear of Mounting Rail (inside)	465 mm (18.3 in).
Front Panel to Rear of Mounting Rail (outside)	472 mm (18.6 in).
Handles	44 mm (1.75 in).
Required Clearance Dimensions	
Height	≥ 178 mm (7 in).
Width	≥ 448 mm (17-5/8 in).
Depth	≥ 508 mm (20 in).
Cooling	Forced air circulation; no air filter.
Finish	Tek Blue finish painted on pebble-grain aluminum cabinet.
Construction	Aluminum alloy chassis, front-panel frame, and rear support. Plastic-laminate front panel.

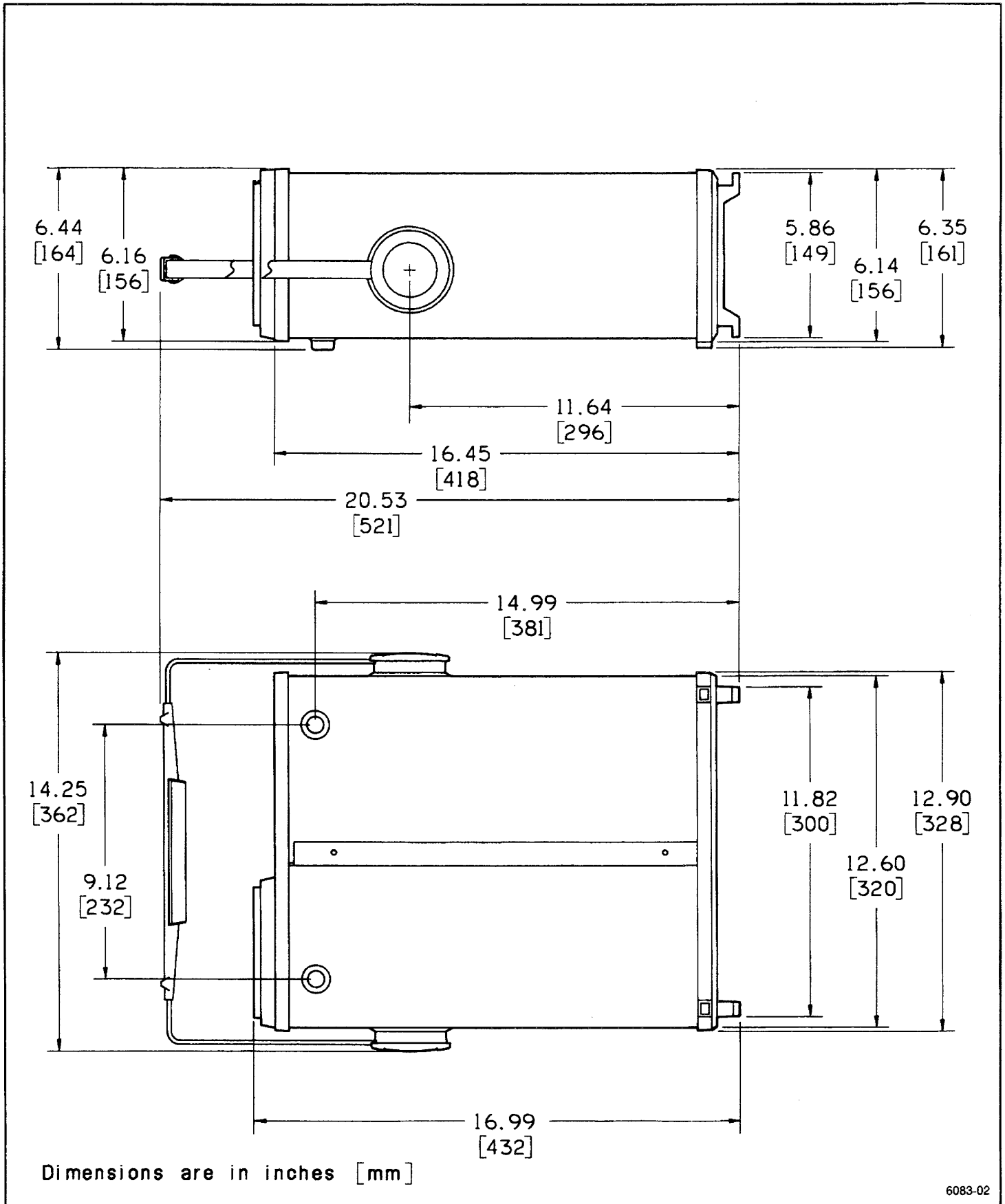

6083-02

Figure 1-2. Dimensional outline drawing, standard cabinet.

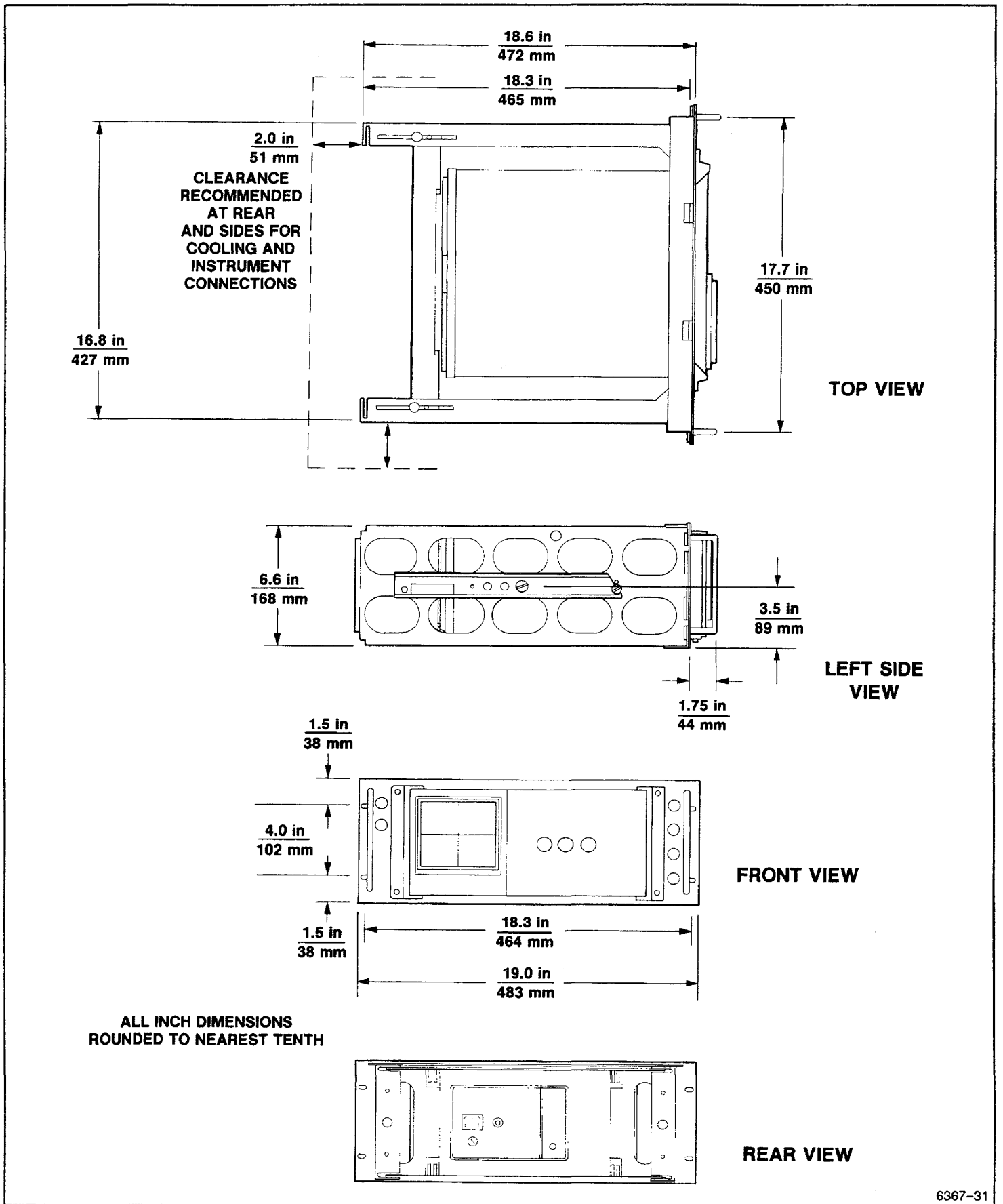

Figure 1-3. Dimensional outline drawing, rackmount cabinet.

*This Document is a complete Scan from the original
Tektronix manual*

*For enquiries about our complete
High quality line of technical Manuals in PDF*

mailto : Qservice@otenet.gr

**SEE
OTHER
SIDE**

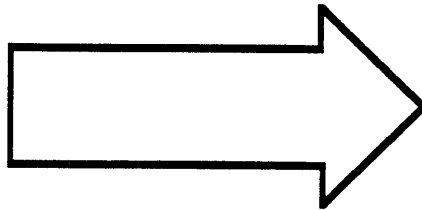

PREPARATION FOR USE

SAFETY

This section tells how to prepare for and to proceed with the initial start-up of the instrument.

Refer to the Safety Summaries at the front of this manual for power source, grounding, and other safety information about the use of the instrument. Before connecting the 2247A to a power source, read this section and the Safety Summaries.

LINE VOLTAGE AND POWER CORD

The 2247A operates on line voltages from 90 to 250 V with line frequencies ranging from 48 to 440 Hz. No line voltage selection is necessary. Instruments are shipped with the power cord that was requested on the order. The power cord must match the power-source outlet; if it does not, contact your Tektronix representative or local Tektronix Field Office. See Figure 2-1 for optional power cords available.

WARNING



For electrical-shock protection, insert the power plug into a power-source outlet that has a properly grounded protective-ground contact.

The detachable three-wire power cord has a three-contact plug for connection to the power source and the protective ground. The power cord is held to the rear panel by a clamp. The protective ground contact on the plug connects (through the power cord protective-ground conductor) to the accessible metal parts of the instrument.

LINE FUSE

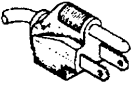
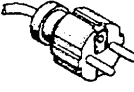

This instrument can be damaged if the wrong line fuse is installed.

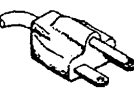
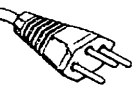
Plug Configuration	Option	Power Cord/ Plug Type	Line Voltage	Reference Standards ^b
	U.S. Std.	U.S. 120V	120V	ANSI C73.11 NEMA 5-15-P IEC 83 UL 198.6
	A1	EURO 220V	220V	CEE(7), II, IV, VII IEC 83 IEC 127
	A2	UK ^a 240V	240V	BS 1363 IEC 83 IEC 127
	A3	Australian 240V	240V	AS C112 IEC 127
	A4	North American 240V	240V	ANSI C73.20 NEMA 6-15-P IEC 83 UL 198.6
	A5	Switzerland 220V	220V	SEV IEC 127

^a A 6A, type C fuse is also installed inside the plug of the Option A2 power cord.

^b Reference Standards Abbreviations:

ANSI – American National Standards Institute
AS – Standards Association of Australia
BS – British Standards Institution
CEE – International Commission on Rules for the Approval of Electrical Equipment
IEC – International Electrotechnical Commission
NEMA – National Electrical Manufacturer's Association
SEV – Schweizerischer Elektrotechnischer Verein
UL – Underwriters Laboratories Inc.

Figure 2-1. Optional power cords.

Verify the proper value of the power-input fuse with the following procedure:

1. Disconnect the power cord from the power-input source.
2. Press in the fuse-holder cap and release it with a slight counterclockwise rotation.
3. Pull the cap (with the attached fuse inside) out of the fuse holder.

4. Verify proper fuse value.
5. Install the proper fuse and reinstall the fuse-holder cap.

INSTRUMENT COOLING

To prevent instrument damage from overheated components, make sure the internal airflow is not blocked. Before turning on the power, check that the ventilation holes on the bottom and side of the cabinet are not covered. After turning the instrument on, check that air is being exhausted from the right-side ventilation holes.

START-UP

When the power is turned on, the instrument does a self-diagnostic check. If the instrument does not turn on and operate normally, turn power off and then on again. If the instrument still does not turn on properly, the TRIGGER MODE LEDs may be flashing to indicate the circuit location of a start-up error. Refer to Troubleshooting in the Maintenance section of this manual for an explanation of the start-up error codes.

When the 2247A is turned on, a self-cal routine may run to set the voltage- and timing-measurement constants. The power-on self cal runs only if the stored constants have been lost, possibly due to a dead memory back-up battery. The following warning message will be displayed for 5 seconds: "WARNING PROBABLE BATTERY FAILURE TURN OFF AND ON TO VERIFY." The instrument can still be used for accurate measurements by running the SELF CAL MEASUREMENTS routine from the Service Menu after the instrument has warmed up for at least 20 minutes.

To run the SELF CAL MEASUREMENTS routine:

Press the top and bottom menu-select buttons to access the Service Menu; then select SELF CAL MEASUREMENTS and press RUN to start the routine. On completion of the SELF CAL routine, select QUIT from the Service Menu or press the CLEAR DISPLAY button to return to the normal oscilloscope mode.

DETAILED OPERATING INFORMATION

For operating information about specific instrument functions, refer to the 2247A Operators Manual.

THEORY OF OPERATION

SECTION ORGANIZATION

This section contains general and detailed descriptions of the 2247A Oscilloscope circuitry. The Block Diagram Description describes the general operation of the instrument functional circuits. Each major circuit is explained in detail in the Detailed Circuit Description. Schematic and block diagrams show the circuit components and interconnections between parts of the circuitry. The circuit descriptions are arranged in the same order as the schematic diagrams.

The detailed block diagrams and the schematic diagrams are in the Diagrams section at the rear of this manual. Smaller functional diagrams are in this section near the associated text. The schematic diagram associated with each circuit description is identified in the text. For best understanding of the circuit being described, refer to the applicable schematic and functional block diagrams.

INTEGRATED CIRCUIT DESCRIPTIONS

Digital Logic Conventions

Digital logic circuits perform many functions within the instrument. Functions and operation of the logic circuits

are represented by logic symbology and terminology. Most logic functions are described using the positive-logic convention. Positive logic is a system where the more positive of two levels is the TRUE (or 1) state; the more negative level is the FALSE (or 0) state. In this logic description, the TRUE state is high, and the FALSE state is low. Voltages of a high or low state vary among individual devices. For specific device characteristics of common parts, refer to the manufacturer's data book.

Hybrids

The Channel 1 and Channel 2 attenuators and input buffers are hybrid devices combining thick-film and semiconductor technologies. These devices are made with interconnected circuitry on a single ceramic carrier and have improved performance characteristics over a more discrete type circuit.

Linear Devices

The operation of individual linear integrated circuit devices is described in this section using waveforms or graphic techniques when needed to illustrate their circuit action.

BLOCK DIAGRAM DESCRIPTION

INTRODUCTION

The Block Diagram Description gives an overview of the schematic circuit functions as illustrated in Figure 3-1. It is provided as an aid in understanding the overall operation of the 2247A Oscilloscope circuitry before individual circuits are discussed in detail. The Simplified Block Diagram illustration shows the basic interconnections for signal flow and control signals. Schematic diagram numbers that are referred to in the text are shown by a diamond symbol in each block of the figure.

VERTICAL INPUTS (Diagram 1)

The signals for viewing or for triggering are applied to the CH 1 through CH 4 vertical input BNC connectors via coaxial cables or probes. Channels 1 and 2 have a choice of AC or DC input coupling or GND. Channels 3 and 4 have DC input coupling only. Scaling of the Channel 1 and Channel 2 input signals has a range of 2 mV per division to 5 V per division without the use of external attenuators. Channels 3 and 4 are limited to two input attenuator choices: 0.1 V per division and 0.5 V per division.

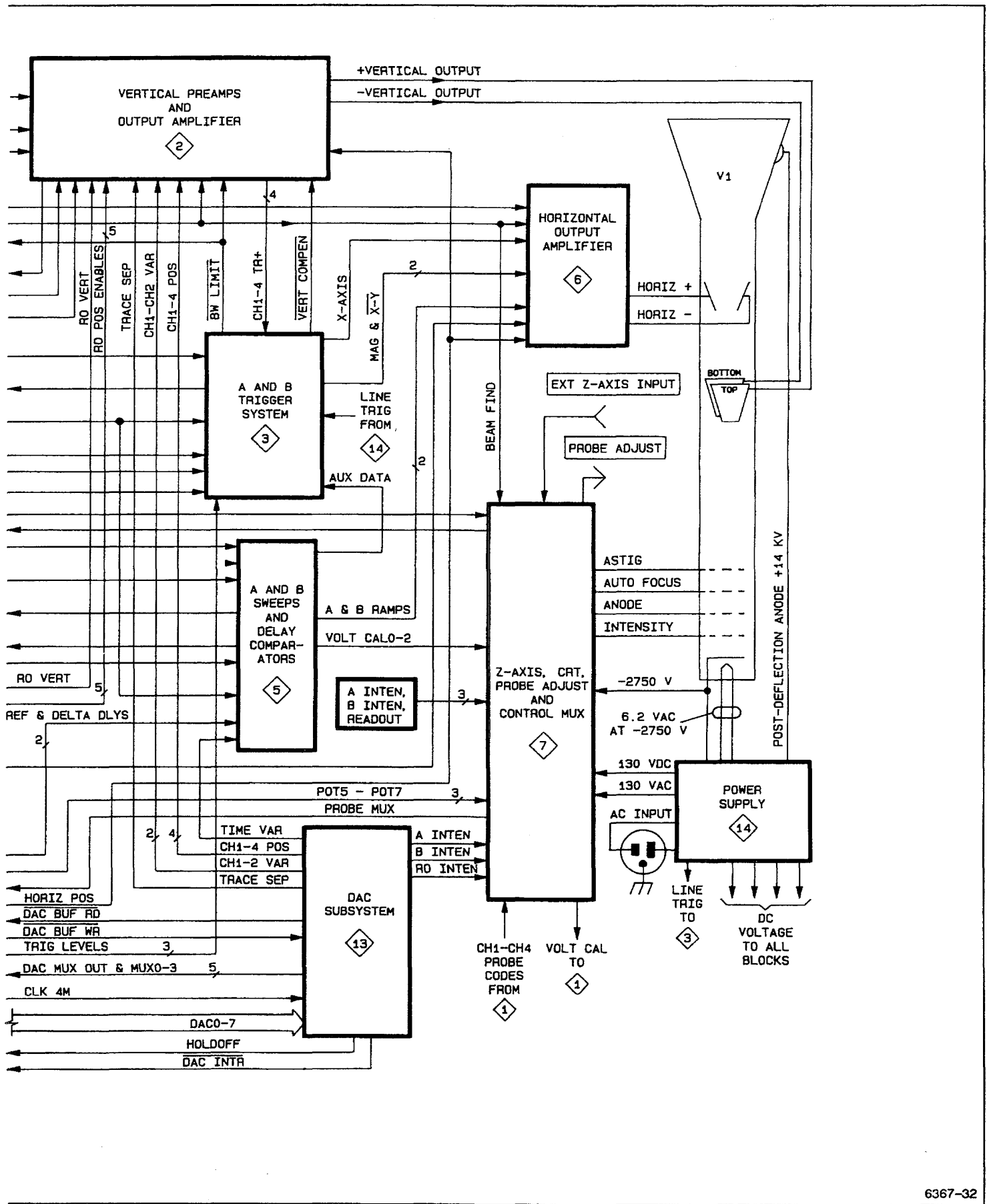

Figure 3-1. Simplified block diagram (cont).

6367-32

Scaling of the Channel 1 and Channel 2 signals is done by a series of switchable attenuators that provide either no attenuation, X10 attenuation, or X100 attenuation of the input signal. A low-impedance attenuator following an input signal buffer produces X1, X2, and X5 attenuation steps. Additional control of input signal scaling is provided by the selectable gain Vertical Preamplifiers (shown in Diagram 2).

Channel 3 and Channel 4 input signals are buffered by high input impedance FET amplifiers; input attenuation of the signal is fixed. The gain choices for Channel 3 and Channel 4 are selected by the choice of Vertical Preamplifier gain setting only.

The Measurement Processor controls the operation of much of the switchable circuitry of the 2247A via a common shift register data line (SR DATA). Data bits loaded into the attenuator control and gain shift register (designated SR0) set the magnetic relay switches for the input coupling and attenuator settings and select the gain settings of the Preamplifiers.

VERTICAL PREAMPS AND OUTPUT AMPLIFIER (Diagram 2)

Each vertical channel has identical selectable-gain Preamplifiers. The calibrated gain for each is manually set during adjustment. Enabling of the Preamplifiers to display a channel input signal is controlled by the Display Sequencer (U600, Diagram 4). Preamplifier gain settings are controlled by the Measurement Processor via control bits loaded into the attenuator control and gain shift register (Diagram 1). Vertical channel trigger signal outputs are produced by each of the Preamplifiers for triggering the sweep from the applied signal.

The vertical outputs of each preamplifier are connected to a summing node at the input to the Delay-Line Driver. There, the signal current (from the enabled Preamplifiers) and the no-signal standing currents (from the disabled Preamplifiers) are added with the current from the position signal switching circuit.

The signal current for the enabled channel (vertical channel signal plus its position offset) or the readout position current (enabled to the summing node during text and cursor displays) is applied to the Delay-Line Driver. There, it is buffered and compensated to drive the vertical delay line. The delay line produces enough delay in the signal to permit the trigger circuitry to start the sweep before the vertical signal arrives at the crt

deflection plates, and the rising edge of the triggering signal may be viewed.

From the output of the delay line, the signals are applied to the Vertical Output integrated circuit. The Vertical Output IC (U701) has provisions for vertical BEAM FIND and bandwidth limiting. External filter elements on the Vertical Output IC produce the bandwidth limiting when switched into the amplifier circuitry. The output signal from U701 is then applied to the Vertical Output Amplifier where it gets its final boost in power to drive the vertical crt deflection plates.

An auxiliary Vertical Comparator circuit (U702 and Q703) is shown in Diagram 2. Its purpose is to measure the gains and offsets during SELF CAL to determine the vertical calibration constants needed for the measurements and tracking cursor displays.

A AND B TRIGGER SYSTEM (Diagram 3)

The A and B Trigger System provides the circuitry for trigger source, slope, coupling, and bandwidth selection; trigger level comparison; tv trigger detection; and dc measurements of the measurement source signal.

Trigger selection signals from the Display Sequencer (U600, Diagram 4) drive the switching circuitry internal to U421 and U431. The signals select the correct trigger source, slope, and coupling choice for the present front panel control setting. For VERT MODE triggering with more than one vertical channel displayed, the trigger source selection changes as each channel is displayed. When the ADD Vertical Mode is selected, a special amplifier arrangement in U421 (for A) or U431 (for B) sums the CH 1 and CH 2 signals to provide an ADD trigger signal for display of the ADD waveform.

The Trigger CPLG (coupling) selections are AC, DC, HF REJ (high-frequency reject), LF REJ (low-frequency reject), and NOISE REJ. Of these, all but NOISE REJ coupling are produced by selecting a filter path with the necessary bandwidth characteristics. NOISE REJ coupling is done in the Trigger Level Comparator circuit by decreasing the sensitivity of the comparator.

When the trigger signal level crosses the comparator threshold set by the Trigger LEVEL and SLOPE control settings, the comparator output changes states. That state change is applied to the Trigger Logic IC (U602, Diagram 4). The Trigger Logic circuitry then produces the gating that starts the A or B Sweep as appropriate.

Separate A and B Trigger bandwidth limit circuits before the Trigger Level Comparators allow the flexibility that is

needed for using the B Trigger circuitry as the measurement signal channel. Signals are measured by using the B Trigger Level Comparator as a successive-approximation analog-to-digital converter to determine the peaks or dc level of the applied signal. When making a measurement, the B Trigger Level signal is driven in a binary search by the Measurement Processor (via the DAC system, Diagram 9) while the output of the B Trigger Level Comparator is monitored. When the smallest resolution output of the DAC system causes the comparator output to change states, the Measurement Processor stops the search and uses the DAC input value at that point as the measured value of the applied signal.

Video signal processing to obtain either Field or Line triggering is done in the TV Trigger Detector. Peak detectors determine the negative or positive peaks of the applied video signal. Those levels set the voltage at the reference input of the video signal comparator at a level that strips off all the video information (when the slope selection is correct for the polarity of the applied signal). The remaining composite sync signal is applied directly to the trigger system for Line triggering. Field triggering is obtained by filtering the composite sync to obtain only the vertical sync pulse.

The operating modes of the Trigger circuitry are controlled by the Measurement Processor. Auxiliary Data Shift Register U1103 (the last device in shift register 1) is serially loaded with control bits from the SR DATA line by the SR1 TTL clock. The state (high or low) of the control bits select the bandwidth setting of the A and B Triggers, TV LINE or TV FIELD triggering for the A Trigger system, and either the TV FIELD signal or the average DC voltage of the measurement channel for the B Trigger system. Additional control bits output from the Auxiliary Data Shift Register are the MAG signal (X10 Magnification on or off), $\overline{X-Y}$ signal (X-Y or Y-T displays), and the $\overline{VERT COMP ENABLE}$ signal (when vertical SELF CAL is done).

DISPLAY AND TRIGGER LOGIC AND PROCESSOR INTERFACE (Diagram 4)

Two special devices control the display states and the trigger system. The Display Logic IC (U600, also known as SLIC or slow-logic IC) controls activities that enable the vertical channels for display and select the A and B Trigger System operating states. The Trigger Logic IC (U602, also known as FLIC or fast-logic IC) monitors the A and B Trigger signals, the A and B SWP END signals, the DLY END 0 and DLY END 1 signals, and controlling signals from the Display Logic IC. It outputs the A, B, and

C GATE signals (that start the sweeps and measurements) and the Z-Axis signals (that unblank the crt) at the appropriate times.

Setup data to the internal registers of the two logic devices is sent from the Measurement Processor over the MB DATA line. A register is enabled for loading by the address that is latched on the ADDR0-ADDR3 lines (from Diagram 8). Data bits are written to U600 with the $\overline{SLIC WR}$ strobe and to U602 with the $\overline{FLIC WR}$ strobe. The contents of the internal registers of the Display Logic IC may also be read by the Measurement Processor using the $\overline{SLIC RD}$ strobe.

The Processor Interface portion of Diagram 4 handles the serial communications between the serial shift registers and the Measurement Processor. This circuitry is the Measurement Processor's means of controlling the circuit hardware setups in response to a front panel control setting. Data controlling the state of the serial data bit to be loaded into the shift registers is placed on the ADDR0-ADDR2 bus lines. That address is decoded to produce either a high or a low that is latched on the SR DATA signal line. The appropriate shift register clock is then generated to load the latched bit. Each bit is loaded in succession until all the control bits of a shift register are loaded.

Shift register U502 permits the Measurement Processor to read back the outputs of the shift registers for diagnostic purposes and the output of the Vertical Comparator during vertical SELF CAL. The last bit from shift register 0 and shift register 1 ($\overline{RO FREEZE}$ and $\overline{BW LIMIT}$ respectively) and the Vertical Comparator (VERT COMP) state are loaded in parallel and serially shifted out onto the MB RETURN line to be read by the Measurement Processor.

A AND B SWEEPS AND DELAY COMPARATORS (Diagram 5)

The A and B Sweep circuitry sets the timing and produces the A and B ramp signals to drive the crt horizontal deflection plates. The Measurement Processor sets the hardware states using control bits loaded into the sweep control shift registers. One register (U302) holds the bits for selecting the A Sweep timing resistors and capacitors and one register (U303) holds the B Sweep control bits. The timing resistors are selected by multiplexers (U307 and U308 for A Sweep timing; U310 and U311 for B Sweep timing) that are switched by the states of the control bits; timing capacitors are selected directly by the control bits.

The starting level of the sweeps is held steady by a Baseline Stabilizing circuit, and the sweep ends are

determined by two Sweep-End Comparators. A and B GATE signals from the Trigger Logic IC (U602, Diagram 4) control the start of the sweep ramps. A constant charging current to the timing capacitors produces a linear voltage rise across the capacitors. That voltage is buffered by the A and B Sweep Buffers for application to the Horizontal Output Amplifier (Diagram 6).

The SEC/DIV VAR control, when out of the calibrated detent position, changes the charging current delivered to the sweep timing capacitors proportional to its rotation. Decreasing the current lengthens the ramp to decrease the sweep speed.

Two comparator circuits are used to check the A Sweep ramp amplitude against the Reference Delay and Delta Delay voltages. Both Delay End Comparator outputs are applied to the Trigger Logic IC (U602, Diagram 4). The Trigger Logic IC monitors the delays to determine when the B Sweep may either run (for RUNS AFTER B Trigger Mode) or accept a B Trigger (for any of the triggered B Sweep modes).

HORIZONTAL OUTPUT AMPLIFIER (Diagram 6)

Deflection signals applied to the Horizontal Preamplifier (U802) are the A Sweep Ramp, the B Sweep Ramp, the horizontal readout, and the X-Axis input signal for X-Y displays. Mode control signals HD0 and HD1 (from Display Logic IC U600 to the Horizontal Preamplifier) select the horizontal display mode (A Sweep, B Sweep, readout, or X-Y display). Other control signals to the Horizontal Preamplifier are the MAG signal (for X10 magnification of the sweep), the RO REQ DLY signal (turns off magnification during readout display), the BEAM FIND signal (decreases horizontal gain), and the horizontal position signal for positioning the display. The X-Y signal controlling U301B reduces the range of the Horizontal POSITION signal delivered to the Horizontal Preamplifier when in X-Y display mode.

Five manual adjustments are associated with the Horizontal Preamplifier. They are the X10 and X1 gain, the Readout gain, the X-Axis signal gain, and Mag Registration. Mag Registration compensates for offset between X10 and X1 modes, but it is primarily used to center the readout displays horizontally.

The active single-ended deflection signal input to the Horizontal Preamplifier is amplified and converted to a differential output signal. That signal is further amplified and compensated by the Horizontal Output Amplifier to

drive the horizontal deflection plates of the crt. The final output amplifier consists of four transistors (Q801, Q802, Q805, and Q806). Two transistors are used for each deflection plate (left and right) to divide the power handling requirements.

Z-AXIS, CRT, PROBE ADJUST, AND CONTROL MUX (Diagram 7)

This block of circuitry is divided into several different functions. The largest division is the Z-Axis and CRT circuitry. A INTEN, B INTEN, and RO INTEN input signals (from the Dac Subsystem board and the front panel controls) are applied to the Z-Axis circuit to set the associated display intensities. Enabling gates from U602 (Diagram 4) select the appropriate Z-Axis input signal for application to the Z-Axis amplifier as the different display types are enabled. The amplified Z-Axis signals are then level shifted to the negative voltage of the crt cathode (-2.7 kV) in a dc restorer circuit. A similar dc restorer circuit provides auto focusing (at the fixed focus level set by the front panel FOCUS control) in response to the intensity level changes. The intensity and auto focus control voltages are applied to the crt where they modulate the electron beam flow that produces the display seen on the screen.

Multiplexer U506, under control of the Measurement Processor, scans the front panel intensity potentiometers and the probe code lines to check for a change. Signal selection for routing through the multiplexer is controlled by the three bits on the POT5-POT7 bus lines from the Pot Data Latch (Diagram 11). Output from multiplexer U506 is routed to the Front Panel Multiplexer (U2309, Diagram 11) and multiplexed with other front panel control levels. Outputs from U2309 are routed to the A-to-D Comparator (U2306, Diagram 11) where a digital value representing their analog voltage level is determined. That value is checked against the previously obtained value for a selected potentiometer or probe code to determine if a change has occurred and, if so, the amount and direction of the change. The Measurement Processor uses that information to generate new control voltages to the circuitry affected by the change.

The Probe Adjust circuit (U930 and associated circuitry) produces a square-wave signal which is output to the front panel PROBE ADJUST jack for compensating voltage probes and checking the vertical deflection system of the oscilloscope.

The Volts Cal Signal Source circuit (U931 and an associated precision voltage divider) provides the accurate dc

voltage levels used during vertical SELF CAL to check the gain and offset of the measurement channels.

The Scale Illumination circuit is made up of three incandescent graticule lamps and current-source transistors. The SCALE ILLUM potentiometer sets the bias level on the transistors to control the amount of current to the lamps.

MEASUREMENT PROCESSOR (Diagram 8)

Many of the oscilloscope circuitry functions are directed by the Measurement Processor (U2501). The Measurement Processor, under firmware control, monitors the front panel controls and sets up the circuitry under its control according to the settings made and the instructions contained in the System ROM.

The Measurement Processor communicates directly with the devices on its eight-bit data bus. The Measurement Processor selects the device to transfer data to or from by placing the address of the device on the Measurement Processor Address Bus. That address is decoded to produce a strobe that enables the bus device corresponding to the address. Writing to or reading from the enabled device is controlled by write or read (\overline{WR} and \overline{RD}) pulses from the Measurement Processor. Communication on the data bus is usually limited to high speed data transfer only (to and from the System RAM and from the System ROM) and not direct control of any circuit functions.

For controlling most of the circuit operating states, the Measurement Processor places serial bits on the bidirectional MB DATA line. Appropriate enabling strobes and clocks are generated either in its address decoding circuitry or by the Processor Interface circuitry (Diagram 4) to load the control data into 24-bit or 32-bit shift registers. The outputs of these registers control such things as attenuator settings, preamplifier gains, sweep timing, and trigger operating modes; all circuit operating functions that either change with front panel settings only or at a slow rate.

Scanning of the front panel controls and lighting of the front panel LEDs that back-light the buttons is under control of the Measurement Processor. These events occur at long intervals compared to the operating speed of the Measurement Processor. The front panel switch closures are read by the Measurement Processor over a serial communication line (SW BD DATA).

READOUT SYSTEM (Diagram 9)

The Readout Processor (U2400) controls the display of text and cursor readouts as directed by the Measurement Processor. The ASCII code of each character (blanks included) in a full screen of readout (one field) is loaded into the appropriate memory location of the Character Code RAM (U2406) by the Measurement Processor. It is then up to the Readout Processor to control the display process.

When the Readout Processor addresses the Character Code RAM for display of the loaded characters, the address of a memory location dictates the place that the addressed character will appear on the face of the crt. The ASCII code found at the addressed location in the Character Code RAM then accesses the character to be displayed from the Character Dot Position ROM (U2408). The screen position of an individual dot within an addressed character is directed by the character data obtained from the Character Dot Position ROM.

The data bits specifying the character position on screen and the dot position within a given character are converted to analog vertical and horizontal position signals by the readout DACs (U2412 for vertical and U2413 for horizontal). For cursors and cursor related text, voltages representing the cursor positions are added in the output mixer circuitry (U2414, U2415, and U2416) to place the readout correctly on screen. Vertical position information needed for the measurement-tracking cursors and readouts is added in the Vertical Position Switching circuit (Diagram 2).

The dots are continually refreshed to maintain a flicker-free readout. When the readout data needs changing, the Measurement Processor halts the refreshing and loads the new screen of data into the Character Codes RAM.

SWITCH BOARD AND INTERFACE (Diagram 10)

Most of the front panel switches that can be read by the Measurement Processor are "soft" switches; they are not connected directly into the circuit to be controlled. The front-panel-control physical parameters of capacitance, leakage resistance, and inductance, therefore, cannot affect the operation of the controlled circuit. The wiper voltage of the potentiometers is digitized, and that digitized data is used by the Measurement Processor to set up the circuitry under its control as dictated by the control change.

The momentary push-button switches are rapidly scanned at short intervals by the Measurement

Processor to check if one is being pressed. When a switch closure is detected, the Measurement Processor makes the necessary circuit or display changes as directed by its firmware instructions for that button and the existing operating states.

Functions are shown to be on by turning on the LED (light-emitting diode) that back-lights the push button or panel label. The Measurement Processor controls the lighting via control registers (U2523 and U2524) that it reloads with control data to enable the correct LED with each button or mode change.

ADC AND DAC SYSTEM (Diagram 11)

The ADC and DAC system is the Measurement Processor's control link to the analog circuitry. When the Measurement Processor does a scan to determine the front panel control settings, the DAC system drives the input to the A-to-D Comparator (U2306) in a binary search pattern to determine the voltage level applied to the other input of the comparator. The smallest incremental change in the DAC input data that produces a switch in the comparator's output identifies the digital value of the unknown voltage. The output of the comparator (AD COMP) is applied to the Data Buffer U2515 on Diagram 8.

COUNTER/TIMER (Diagram 12)

The Counter/Timer (C/T) circuitry includes a 10 MHz crystal oscillator, an external timebase input, slow counter logic (SCL), fast counter logic (FCL), level translators, and a phase-locked loop. The phase-locked loop consists of a phase-frequency comparator (PFC), summer, loop filter, voltage-controlled oscillator (VCO), and a frequency divider (parts of which are in SCL and FCL).

The Counter/Timer hardware can be configured in three basic modes:

- Period mode—used for all frequency and period measurements.
- Width mode—used for WIDTH, GATED WIDTH, TOTALIZE, and GATED EVENTS.
- Delta-time mode—used for SEC, 1/SEC, and PHASE when cursors are not used; used for RISE, FALL and PROPDLY.

Period mode operates as follows: The Measurement Processor (Diagram 8) sets a bit (called ENABLE) in FCL to tell the Counter/Timer to start counting on the next trigger edge. When this trigger edge occurs, the BUSY line goes high to indicate that the C/T has started measuring, the B counter starts counting trigger signal periods, and the A counter starts counting periods of the 200 MHz TC input signal. After the measurement time is up, the Measurement Processor sets the ENABLE bit low. Then the A and B counters stop counting after the next trigger edge, and the BUSY line goes low (C/T measurements start and stop synchronously with the trigger signal). The Measurement Processor then calculates the period, which will be equal to:

$$\frac{(A \text{ count}) \times (TC \text{ period})}{(B \text{ count})}$$

(TC period = 5 ns)

To display frequency, the Measurement Processor inverts the above value:

$$\text{Frequency} = \frac{1}{\text{Period}}$$

When a gated frequency or period measurement is performed, the procedure is essentially the same, except that the $\overline{C \text{ GATE}}$ signal is used to arm the C/T instead of the ENABLE bit (the ENABLE bit is still used, to tell the C/T when to start arming itself with $\overline{C \text{ GATE}}$). For each $\overline{C \text{ GATE}}$ interval in which there is a trigger edge (when the C/T is enabled), the BUSY signal will toggle high; BUSY then toggles low on the first trigger edge just after the end of $\overline{C \text{ GATE}}$.

Width mode works about the same as period mode, except that the A counter only counts when the trigger signal is high (in addition to the C/T being enabled, etc.). Width of the trigger signal is calculated the same way as period.

In gated events measurements, the C counter counts the number of times $\overline{C \text{ GATE}}$ occurs during the measurement, while the B counter counts the total number of trigger edges that occurred in the $\overline{C \text{ GATE}}$ interval. The averaged event count (number of edges that occurred in one $\overline{C \text{ GATE}}$ interval) is:

$$\frac{(B \text{ count})}{(C \text{ count})}$$

In delta-time C/T measurements, all three count chains are used. To start a measurement, ENABLE is set high by the Measurement Processor. When a Delay Select (DS) positive edge occurs, the C/T starts measuring the delay intervals (times from A GATE leading edge to B GATE leading edge). When DS is high, the A counter accumulates TC periods occurring during the first delay interval (reference delay), and when DS is low, the B counter accumulates TC periods occurring during the second delay interval (delta delay). The C counter accumulates the number of times that BUSY went high to low; this count, divided by two, equals the total number of delta time intervals averaged during the measurement. When ENABLE is set low, the next DS positive edge will cause the measurement to end. The delta time value will be:

$$\frac{(B \text{ count} - A \text{ count}) \times (TC \text{ period})}{\left[\frac{(C \text{ count})}{2} \right]}$$

DAC SUBSYSTEM (Diagram 13)

The DAC Subsystem circuit, under control of the Measurement Processor (Diagram 8), converts digitized front panel control voltages to analog voltages that are

used to control individual circuits. The digital control voltages may be either from the front panel potentiometers or from the Store/Recall or Autaset operations.

Processor U2601 refreshes D/A converter U2602 and directs multiplexers U2604, U2605, and U2303 (Diagram 11) to output front panel control analog levels to the circuitry to be controlled.

POWER SUPPLY (Diagram 14)

The low and high voltages required to power the 2247A are produced by a high-efficiency, switching power supply. Input ac voltage from 90 to 250 volts and from 48 to 445 Hz is converted to a dc voltage that powers a preregulator circuit. The preregulator supplies regulated power to an inverter switching circuit in the primary of the power transformer (T2204). The secondary voltages produced at the secondary windings of the transformer are rectified and filtered to provide the low voltage power requirements of the instrument.

High voltage to drive the crt is generated by a multiplier circuit (U2203) that provides the +14 kV post-deflection anode voltage and the -2.7 kV to the cathode. The 6.2 Vac heater voltage is supplied by an isolated secondary winding from the power transformer that is referenced to the -2.7 kV cathode voltage.

DETAILED CIRCUIT DESCRIPTION

VERTICAL INPUTS (Diagram 1)

Channel 1 and Channel 2 input circuits on this schematic diagram are arranged identically. Only Channel 1 circuit numbers are referred to in the discussion. CH 3 and CH 4 are also arranged identically to each other and described separately from CH 1 and CH 2.

Input Coupling

Signals applied to the CH 1 BNC connector are coupled to the CH 1 attenuator via the CH 1 Input Coupling circuit. Relay K100 switches between direct (DC) and capacitive coupling (AC) of the input signal; K101 switches between connecting the applied input signal and the VOLT CAL signal to the input of the attenuator. The VOLT CAL signal line provides either the ground for

GND Coupling in normal oscilloscope operation or a test voltage input for characterization during vertical SELF CAL. With the Input Coupling set to GND (both AC and DC off), the signal path is bypassed by C113. That capacitor filters any noise from the VOLT CAL signal line. There is no precharge of the input coupling capacitor (C112) when the coupling is in ground (GND). Resistor (R111), in series with the BNC input, is a damping resistor.

The probe coding signal (CH1 PRB) is applied to a multiplexer (U506, Diagram 7) where it is selected to be digitized in turn with the other probe-code signals and the front panel potentiometers. The Measurement Processor determines, from the digitized value of the voltage, the attenuation factor of any attached coded probe (Tektronix coded probes). The scale factor of the VOLTS/DIV readout is then switched to reflect the correct

scaling of the displayed signal. Uncoded probes and coaxial cables are interpreted as having no attenuation for setting the readout scale factors.

High-Impedance Attenuator

Switching relays K102 and K103 control the signal path through the high-impedance hybrid attenuator, AT117. Signal attenuation is done by two 10X attenuator sections; for 100X attenuation, the two sections are cascaded. The 1 M Ω termination resistance at the output of the attenuator is divided into two parts: 750 k Ω and 250 k Ω . An output taken across the total resistance is applied to the buffer amplifier fast-path input; another output taken across the 250 k Ω section is applied to the slow-path input. Low-frequency compensation for the hybrid attenuators is adjusted by C10 and C11 (part of the hybrid circuitry on the ceramic carrier); input C is adjusted using C114.

Input Buffer Amplifier and 1X, 2X, 5X Attenuators

Input Buffer Amplifier U112 (for CH 1) is also a hybrid device. The amplifier portion of the circuitry is a fast-path/slow-path buffer having unity voltage gain that presents a high-resistance, low-capacitance load to the signal from the high-impedance attenuator. The amplifier presents a low output impedance to the low-impedance attenuator at its output. The switchable low-impedance, voltage divider network of U112 provides 1, 2, and 5 times attenuation of the output signal for application to the Vertical Preamplifier.

The input signal is applied to pin 2 (fast-path input) and pin 4 (slow-path input) of U112 from the 1 M Ω divider at the output of the high-impedance attenuator, AT117. Internal circuitry of U112 isolates the signal from loading by the low-impedance attenuator and provides the slow-path and fast-path signal amplification. The fast amplifier path quickly passes the fast leading and falling edges of an input signal with the slow path catching up to complete the signal transfer. The output of the buffer sees a 300 Ω input impedance to the low-impedance attenuator, and the preamplifier sees a 75 Ω output impedance at pin 8 of U112 for all VOLTS/DIV switch settings.

Attenuator and Vertical Gain Control Registers

The switching relays of Channel 1 are driven by transistor array U174. Drive to each of the transistors in the array to switch the relay states is supplied by the Measurement Processor (U2501) via U171. That device is a portion of a shift register formed by U171, U172 (for channel 2 relays), and U173 (for Preamplifier gains). The devices are connected in series to form one long shift register (designated Shift Register 0). Serial data bits for the entire register string are loaded at pin 2 of U171 from the SR DATA line by the SR0 CLOCK applied to pin 3 of all three devices. See Table 3-1 for data bit assignments. Tables 3-2, 3-3, 3-4, and 3-5 define the bit states for controlling the switching.

While the control bits are being loaded into the shift registers, the circuit of Q171, CR171, C173, and R175 (on pin 1 of U171 and U172) holds the output latches of the registers in their old states. When the SRO CLK stops changing, C173 is allowed to charge high again, and the new data is latched to the output pins of the registers. All the relays are switched to their new states at that time.

CH 3 and CH 4 Input Amplifiers

The CH 3 and CH 4 input buffer amplifiers are identical discrete FET amplifiers. Input coupling for these two vertical inputs is always DC; there is no coupling switch. The 1 M Ω input is formed by a series voltage divider that attenuates the input signal by five times for application to the gate of the input FETs. The VOLTS/DIV setting (either 0.1 V or 0.5 V) is made in the Preamplifier stage of the channel. Operation of CH 3 is described; like components in CH 4 do the same job.

From the gate of Q131A, diode CR131 provides protection from negative overvoltages exceeding about -8 V. Input C is adjusted by C134 for low-frequency compensation. High-frequency response is compensated by C138 across load resistor R137. Step balance is adjusted by R141 in the source lead of Q131B. The single-ended output of U131A is applied via R139 (a 75 Ω resistor) to the CH 3 Preamplifier. The impedance seen by the other differential input of the Preamplifier (U230, pin 8, Diagram 2) is matched by the parallel combination of R158 and C159 in series with R160.

The probe-coding signal, CH 3 PRB, is read the same way as the CH 1 and CH 2 probe-coding signals. The VOLTS/DIV readout for Channel 3 is switched to correctly match the probe attenuation factor (when properly coded probes are used).

Table 3-1
Shift Register 0 Bit Assignment

Pin	Signal	Controls
U171		
4	CH 1 GND	K101 – CH 1 GND Coupling (last bit)
5	CH 1 AC	K100 – CH 1 AC Coupling
6	CH 1 X10 1	K102 – CH 1 X10 Attenuator 1
7	CH 1 X10 2	K103 – CH 1 X10 Attenuator 2
14	CH 1 X1	K105 – CH 1 X1 Buffer Attenuation
13	NOT USED	No connection
12	CH 1 X5	K104 – CH 1 X5 Buffer Attenuation
11	CH 1 PREAMP 1	U210 – CH 1 Preamplifier Gain
U172		
4	CH 1 PREAMP 0	U210 – CH 1 Preamplifier Gain
5	CH 2 GND	K108 – CH 2 GND Coupling
6	CH 2 AC	K107 – CH 2 AC Coupling
7	CH 2 X10 1	K109 – CH 2 X10 Attenuator 1
14	CH 2 X10 2	K110 – CH 2 X10 Attenuator 2
13	CH 2 X1	K112 – CH 2 X1 Buffer Attenuation
12	NOT USED	No connection
11	CH 2 X5	K111 – CH 2 X5 Buffer Attenuation
U173		
4	CH 2 PREAMP 1	U220 – CH 2 Preamplifier Gain
5	CH 2 PREAMP 0	U220 – CH 2 Preamplifier Gain
6	CH 2 INVERT	U220 – CH 2 Preamplifier Invert
7	CH 3 PREAMP 1	U230 – CH 3 Preamplifier Gain
14	CH 4 PREAMP 1	U240 – CH 4 Preamplifier Gain
13	ZERO HYST	U431C – B Trigger Comparator Hysteresis
11	RO FREEZE	U509C – Controls Readout for SELF CAL (first bit loaded)

Table 3-2
CH 1 and CH 2 Attenuator and Gain Control Bit States

VOLTS/DIV	X10 1	X10 2	X1	NC	X5	PREAMP1	PREAMP0
2 mV	1	0	1	0	0	0	0
5 mV	1	0	1	0	0	0	1
10 mV	1	0	1	0	0	1	1
20 mV	1	0	0	1	0	1	1
50 mV	1	0	0	0	1	1	1
100 mV	1	1	1	0	0	1	1
200 mV	1	1	0	1	0	1	1
500 mV	1	1	0	0	1	1	1
1 V	0	1	1	0	0	1	1
2 V	0	1	0	1	0	1	1
5 V	0	1	0	0	1	1	1

Table 3-3
Input Coupling Control Bit States

Coupling	GND	AC
GND/CAL	0	1
AC	1	1
DC	1	0

Table 3-4
CH 2 INVERT Control Bit

Setting	CH 2 INV
Normal	0
INVERT	1

Table 3-5
CH 3 and CH 4 Gain Control Bit

VOLTS/DIV	PREAMP1
0.1 V	0
0.5 V	1

VERTICAL PREAMPS AND OUTPUT AMPLIFIER (Diagram 2)

Vertical Preamplifiers

Each input channel has its own Vertical Preamplifier (CH 1–U210, CH 2–U220, CH 3–U230, CH 4–U240). The gain setting of the Preamplifier is controlled by Measurement Processor U2501 via the assigned control bits from Shift Register 0 (see Table 3–2). Channel 1 and Channel 2 require two control bits (on pins 1 and 2 of the Preamplifiers) to set three different gains for 2 mV, 5 mV, and 10 mV VOLTS/DIV scaling. From 10 mV per division and up, the gain of the CH 1 and CH 2 Vertical Preamplifiers is set to 10 mV per division. The 1, 2, 5 scaling sequence for the remaining VOLTS/DIV switch settings is obtained by switching the high- and low-impedance attenuators. Gain of the CH 3 and CH 4 preamplifiers is controlled by one bit each (on pin 2), since there are only two scaling settings (0.1 V and 0.5 V per division) to select (see Table 3–5 for the gain-control bit states).

The internal circuitry of each Vertical Preamplifier is matched for the 2 mV, 5 mV, and 10 mV gain settings and the dc offsets. The output gain of each Preamplifier is adjusted by varying the common-mode resistance across the output pins (pin 13 to pin 14) to produce calibrated gain for each of the vertical channels.

Each Vertical Preamplifier has a trigger pickoff (pins 17, 18, 19, and 20) for supplying the internal trigger signal to the A and B Trigger Source Selector Multiplexers. Capacitor coupling from pins 17 and 18 to pins 19 and 20 provides a fast-path signal into a duplicate, but level-shifted, slow-path signal line. The negative side of the differential trigger signal is terminated in a capacitor to ground (from pin 19) to provide a balance for the transmission line.

The VOLTS/DIV VAR controls for CH 1 and CH 2 (R2101 and R2103) directly vary the gain of the Vertical Preamplifiers between the calibrated VOLTS/DIV settings. The Measurement Processor detects whether the VAR control for a channel is in or out of its detent position; and, if out, a greater-than symbol (>) is placed in front of the VOLTS/DIV readout to show that the channel is uncalibrated.

Each Preamplifier produces a standing current of about 11 mA into a common summing node. Output of the vertical signal from a Preamplifier is controlled by enabling signals (CH 1 EN through CH 4 EN) from Display Logic IC U600 (shown on Diagram 4). The enabling signal that turns on a vertical channel signal also enables the

position signal current for that channel through the Vertical Position Switching circuit (either U202 or U201) into the summing node.

Delay Line Driver

The Delay Line Driver is a differential amplifier that provides the signal amplification needed to drive the delay line. The circuit is compensated to produce the needed circuit response at the output of the delay line. Both sides of the differential amplifier are identical and circuit operation of the positive side components is described.

Transistors Q250 and Q252 are arranged as a feedback amplifier. The parallel combination of R250A and R250B supplies the feedback from the emitter of Q252 back to the base of Q250. Diode CR260 provides a one-diode voltage drop in the feedback loop for proper biasing of the base-to-collector junction of the input transistor (Q250). Gain of the amplifier is set by the value of common-mode resistor R270 (there is a small dc voltage gain). If the Vertical Preamplifier and Vertical Position circuit output currents are exactly 11 mA (no signal and no offsets) the feedback current is zero. Some standing feedback current will be present if the sum of the input currents is not exactly 55 mA. A 1 mA current change of the input base current to Q250 produces a 41 mV change at the collector of Q252. The no-signal dc output voltage from Q252 is +7.5 V, and the standing current is about 15 mA. The differential voltage between the positive and negative side of the delay line with no signal input is 0 V \pm 0.5 V. The differential signal voltage input to the delay line is about 29 mV per graticule division of deflection.

Biasing of the input transistor bases is supplied by R262 and R264 (for Q250) and R263 and R265 (for Q251). Two resistors in series are used to provide the power handling needed (they are low-wattage precision resistors). The dc voltage at the bases of Q250 and Q251 is maintained at 7.5 V by a bias stabilization circuit. Operational amplifier U260 compares the common-mode voltage at the junction of R254 and R255 to the +7.5 V supply on its pin 3 input. If the base voltage is too low, U260 raises the common-mode emitter voltage (and thereby the base voltage) of the two input transistors.

Compensation components peak up the circuit response to counteract the rolloff effects of the delay line. The three series-rc combinations (C271 and R271, C272 and R272, and C273 and R273) and capacitor C274, between the emitters of Q252 and Q253, compensate different frequency ranges to correctly shape the

circuit response. The series-rc circuit between the collectors of Q252 and Q253 (C275 and R275) damps the gain at high frequencies to prevent oscillation. Impedance matching and input termination of the 75 Ω delay line is done by the parallel-series combination of R278, R279, R280, and R281.

Vertical Position Switching

The Vertical Position Switching circuit consists of buffer amplifiers for the four vertical channel position signals (U203A, B, C, and D), a buffer amplifier for the TRACE SEP signal (U801B), two solid state switch arrays (U201 and U202), and a transistor paraphase amplifier circuit (U280, Q284, and Q285).

The vertical positioning voltages from the front panel POSITION and TRACE SEP controls are applied to the noninverting inputs of the five voltage-follower buffer amplifiers (U203A through U203D and U810B). The inputs and outputs of the amplifiers are capacitively bypassed to eliminate noise from the position signals. The buffered output signals are applied to switching arrays U201 and U202 for selection at the correct time for positioning the displayed trace and position-related readouts.

POSITION VOLTAGE SWITCHES. Selection of the channel or readout position signals to be supplied to the paraphase amplifier summing node is controlled by several sources. The vertical channel enable signals (CH 1 EN through CH 4 EN) from Display Sequencer U600 (Diagram 4) turn on the appropriate channel position signal for the enabled Vertical Preamplifier when displaying waveforms. The nominal position range of the vertical signal is ± 12 divisions.

When position-dependent readout (labeled cursors that follow the vertical channel position controls) is displayed, the RO CH 1 POS EN through RO CH 4 POS EN signals from tri-state latch U2403 (shown on Diagram 9) enable the appropriate vertical position signal into the summing node at the input to the paraphase amplifier. The Readout Position Enable signal lines are tri-stated (open) during display of the channel signals so that the Vertical Channel Enable signals have control of the position enable lines. Also, the Readout Position signals cannot override the Vertical Channel Enable signal levels to turn on a Vertical Channel Preamplifier with the series resistors (R212, R222, R232, and R242) in the signal path. The vertical position of the enabled vertical channel is added to the position of the readout so that the cursors appear at the correct vertical position in the display.

When non-position tracking readout is displayed (i.e., menus and scale-factor readouts), the vertical screen position of the readout is conveyed by the RO VERT signal only. The RO VERT signal is enabled into the summing node input of the paraphase amplifier by the RO VERT EN signal for both readout types (position-tracking or fixed). Extra noise bypassing provided by decoupling components R205, R207, and C268 on the RO VERT signal line reduces jitter of the readout display.

During vertical SELF CAL, the RO CH 1 POS EN through RO CH 4 POS EN signals enable the appropriate vertical position signal into the summing node at the input to the paraphase amplifier without turning on a channel Vertical Preamplifier. The gain and offset of the voltage followers and position switches may then be calculated independently from the vertical channel signal. The computed offsets are then used by the Measurement Processor to correctly place the position-tracking readouts (cursors) on the display relative to the vertical position of the waveform.

The TRACE SEP EN and RO TR SEP EN signals operate the same as described for the channel enable and readout position enable signals. A slight difference between the channel vertical position signals and the TRACE SEP signal is that TRACE SEP is attenuated more. The higher value of R206 on pin 13 of U201 reduces the TRACE SEP range to ± 4 divisions as compared to ± 12 divisions for the vertical signals.

POSITION PARAPHASE AMPLIFIER. The Position Paraphase amplifier circuitry is formed by a transistor array (U280) driving two discrete transistors (Q284 and Q285). The circuit is configured as two negative-feedback amplifiers that produce a differential output current from the summed single-ended input current. Transistors U280B and U280E are constant-current sources for their associated amplifier pairs in the array. The feedback path for the U280A-U280F amplifier combination is via R286 from the emitter of Q284. The no-signal feedback current through R286 is 1 mA. Feedback for the U280C-U280D combination is via R289 from the emitter of Q285. Feedback current in R289 is 100 μ A. Both Q284 and Q285 are high beta transistors requiring little base-drive current. The overall vertical displacement response from the input (at the base of U280F) to the output is 200 μ A per division of vertical screen displacement.

The signal applied to the base of U280C is the inverted position signal developed across R290 in the emitter of Q284. The signal is again inverted by U280C to drive the base of Q285 in the opposite direction from the signal at

the base of Q284. The standing dc current (no signal input) output current into the delay line input summing node is 11 mA, the same as the output of the vertical pre-amplifiers. Vertical centering of the menu and readout displays within the graticule area is done using RO VERT CENTERING potentiometer R260.

Vertical Output Amplifier

WARNING

Vertical Output IC U701 runs hot and can burn you if touched. The metal tab on top of the device is NOT ground; it is the -5 V supply to the IC.

Vertical Output IC U701 buffers the signal output of the delay line and provides the circuitry for the BW LIMIT and BEAM FIND functions and for the vertical signal gain adjustment. The inputs to the Vertical Amplifier are terminated in 75 Ω by external resistors R706 and R707. External filter components C707, L701, and L702 produce the bandwidth limiting of the vertical signal when internally switched into the output amplifier circuitry of U701.

Manual calibration of the vertical signal display to the crt graticule is done using VO GAIN potentiometer R703. The components between pins 12 and 22 of U701 (Q704, R726, R727, and R728) provide gain correction for the small difference in gain between full bandwidth and bandwidth-limited operation of the Vertical Output IC. Correction for a thermal change between display of the signal and display of the readout is provided by the RO JITTER adjustment (R724).

WARNING

Vertical Output Amplifiers Q701 and Q702 run hot and can burn you if touched.

Vertical Output Amplifiers Q701 and Q702 provide the signal gain necessary to drive the vertical crt deflection plates. The deflection plates have a comparatively large capacitance, and to change the voltage as fast as necessary to deflect the crt beam, the Vertical Output

Amplifiers have to handle large current demands. A reduction in circuit capacity is made by reducing the collector capacitance of the output transistors. The cases of Q701 and Q702 are NOT the collectors; they are connected to the transistors' base material; the case tabs mark the collector leads. In the collector circuits, T-coils L703 and L704 boost the vertical bandwidth of the output amplifiers; and R731 and R732 are damping resistors.

Vertical Comparator

The Vertical Comparator circuit (U702, Q703, and associated components) allows the Measurement Processor to determine the gain and offset of the vertical system up to the input to the Vertical Preamplifier. The circuit is enabled only during the vertical self characterization routine. Known dc voltage levels are applied to the attenuator inputs, and U702 compares the voltage from the delay line to the HORIZ POS signal which is being driven in a binary search pattern. The output voltage is found by successively narrowing the search levels until the smallest change possible from the DAC system causes the Vertical Comparator output to change states. Using the measured value to compare against the known input voltage, the Measurement Processor determines a Vertical Calibration constant that must be applied to produce accurate voltage measurements.

A AND B TRIGGER SYSTEM (Diagram 3)

Most of the trigger signal switching and trigger level comparator circuitry is contained on two integrated circuit devices (U421 and U431). Within the devices is the logic circuitry that drives the selectable variables of Trigger SOURCE, Trigger CPLG, and Trigger SLOPE for both the A and the B Triggers. Selection of the trigger variables is done by control bits generated by Display Sequencer U600 (Diagram 4). The remaining portions of the circuitry shown in Diagram 3 include the A and B Trigger bandwidth limiting circuitry, the TV Trigger Detector circuitry, the Auxiliary Shift Register (part of Shift Register 1), and the DC Filter for the measurement system. The B Trigger circuitry does double duty in that measurements for the DC, +PEAK, -PEAK, and PEAK-to-PEAK values of a signal are done in the B Trigger channel. Consequently, voltage measurements cannot be done in ALT or B Horizontal Display Modes when the B Trigger circuitry is in use.

A and B Trigger Source Selectors

Analog switching of the Trigger signal sources is done by the circuitry in U421A (for the A Trigger) and U431A (for the B Trigger). The possible Trigger SOURCE selections are the same for both the A and the B Trigger system. They are CH 1, CH 2, CH 3, CH 4, LINE, and VERT. In ALT Vertical MODE when VERT is the selected source, a trigger is obtained in succession for each displayed channel. A stably triggered display will be obtained for each channel signal without regard to frequency relationships between the applied signals. If ADD Vertical MODE is selected, a special adder circuit in U421A and U431A, adds the CH 1 and CH 2 signals to produce an ADD trigger signal composed of the two inputs. The LINE Trigger signal is a sample of the power-line input voltage. Multiplexer U1106A, in the input path for the LINE trigger signal, selects between the LINE signal (for oscilloscope operation) and the TB CAL signal (used for horizontal self characterization).

When a Voltage Measurement is being done, U431A in the B Trigger circuit acts as the measurement channel selector and selects either the CH 1 or the CH 2 input signal to be measured.

A and B Trigger Coupling Selector

Coupling selections for DC, AC, HF REJ, and LF REJ are done by U421B for the A Trigger and U431B for the B Trigger. The trigger signal path is through a filter circuit having the proper bandpass characteristics for the selected trigger coupling. NOISE REJ coupling is done differently. The two Trigger LEVEL Comparators (U421C and U431C) have selectable hysteresis. For NOISE REJ Trigger CPLG, the hysteresis is increased so that a larger signal change is required to produce a state change at the output of the comparators. Trigger Coupling control logic is shown in Table 3-6.

Another signal source selectable in the Trigger Coupling Selectors is the output of the TV Trigger Detector (TV LINE or TV FIELD). An applied composite video signal is separated so that the horizontal line or vertical field sync pulse can be used to trigger the oscilloscope for Television signal display (see TV Trigger Detector description). Selection between LINE or FIELD for the A Trigger source is done by multiplexer U1104A with its output being applied to pin 19 of U421B. Pin 19 of U431B in the B Trigger system has an input of either the TV Line sync signal, for TV triggering of the B Sweep, or the output of

the Measurement Signal Low-Pass Filter, when the DC measurement mode is active.

MEASUREMENT SIGNAL LOW-PASS FILTER. The average dc level of a signal is obtained for measurement by filtering the measurement channel signal to remove all but the dc component of the signal. An active RC filter circuit formed by U1101B, R1154, R1155, C1154, and C1155 does the filtering with U1101B buffering the filtered output voltage to isolate it from loading. The dc level is applied back to the Trigger Coupling switch (U431B, pin 19) for input to the B Trigger Comparator (U431C) where the actual measurement is done (see the B Trigger Comparator description).

A and B Trigger Bandwidth Limit Circuits

The A Trigger Bandwidth Limit circuit components (Q440, U441F, CR432, C432, L432, R432, Q444, and U441E) act to roll off the trigger circuit bandwidth when $\overline{\text{BW LIMIT}}$ is active (low). The B Trigger Bandwidth Limit circuit components do the same job (with some additional compensation components), but can be selected independently of the SCOPE BW front panel setting (by the Measurement Processor using the BW FULL B signal). The B Trigger Bandwidth Limit is used during DC VOLTS measurements when the remainder of the system is in full bandwidth. The actual circuit operation for both is the same, and only the A Trigger Bandwidth limiting action is described.

For full trigger bandwidth, the $\overline{\text{BW LIMIT}}$ signal from Auxiliary Shift Register U1103 is written high by the Measurement Processor. That high is inverted to a low by U441E and U441F and applied to the bases of Q440 and Q444. The low output turns off Q444 and disconnects C444 from ground. The purpose of C444 is to act as part of an LC filter that rolls off the signal. The low applied to the base of Q440 turns that transistor on pulling the anode of CR432 up and forward biasing it. The trigger signal ac path then bypasses L432 and R432 through CR432 and C432. The dc component of the trigger signal is still via L432 and R432.

When the bandwidth is limited, the $\overline{\text{BW LIMIT}}$ signal is low. That is inverted to a high that turns on Q444 (connecting C444 to ground) and turns off Q440 (reverse biasing CR432). The trigger signal path is now through L432 and R432 with C444 connected to ground to roll off the circuit bandwidth.

Table 3-6
Trigger Selection Logic

Front Panel Coupling Selection	Latched Bit Values				Description
	SLOPE	TS2	TS1	TS0	
A Sweep Mode (U421) AUTO LEVEL, AUTO, NORM, or SGL SEQ					
DC	0	0	1	0	DC Coupled
NOISE REJ	1	0	1	0	DC Coupled, Noise Reject
HF REJ	0	1	0	1	HF Reject
LF REJ	0	0	1	1	LF Reject
AC	0	1	0	0	AC Coupled
A Sweep Mode (U421) TV LINE or TV FIELD					
DC	1	0	0	0	TV Input, Noise Reject
NOISE REJ	1	0	0	0	TV Input, Noise Reject
HF REJ	1	0	0	0	TV Input, Noise Reject
LF REJ	1	0	0	0	TV Input, Noise Reject
AC	1	0	0	0	TV Input, Noise Reject
B Sweep Mode (U431) AUTO LEVEL, RUNS AFTER or NORM					
DC	0	0	1	0	DC Coupled
NOISE REJ	1	0	1	0	DC Coupled, Noise Reject
HF REJ	0	1	0	1	HF Reject
LF REJ	0	0	1	1	LF Reject
AC	0	1	0	0	AC Coupled
B Sweep Mode (U432) TV LINE					
DC	1	0	0	0	TV Input, Noise Reject
NOISE REJ	1	0	0	0	TV Input, Noise Reject
HF REJ	1	0	0	0	TV Input, Noise Reject
LF REJ	1	0	0	0	TV Input, Noise Reject
AC	1	0	0	0	TV Input, Noise Reject

A Trigger Comparator

The Trigger signal is compared with the A Trigger LEVEL setting by U421C to determine the signal level and slope of the trigger signal that produces a sweep trigger. The comparator slope is set internally by the switching logic; the Trigger comparison level is set using the front panel Trigger LEVEL control. A fixed amount of hysteresis in the A Trigger Level Comparator prevents double

triggering on signals accompanied by normal noise. NOISE REJ coupling increases the hysteresis by a factor of four to reduce the Comparator's sensitivity to noise if triggering on very noisy signals is required. Once a level state change occurs, a larger change in the opposite direction is required (because of the circuit hysteresis) to reverse the state change. The differential output of U421C is buffered by U442 and applied to the Trigger

Logic IC (U602, Diagram 4) where the gating signals to start the display sweep are generated.

B Trigger Comparator and Measurement A-to-D Converter

For B Trigger signal comparison, the B Trigger Level Comparator (U431C) works the same as the A Trigger Level Comparator. Its differences lay in its use as the Measurement Channel A-to-D Converter for making signal voltage measurements. When a measurement is being done, the ZERO HYST control bit from Shift Register 0 (U173, Diagram 1) is set high. This high turns off Q480 and disconnects U431C pin 1 from ground. The biasing combination of R476 and R486 between the -5 V supply and ground reduces the hysteresis of the B Trigger Comparator to zero. A small incremental change in signal level to the comparator will then cause it to change output states. The B REF TRIG LVL signal on pin 25 of U431C is driven in a binary search pattern by the Measurement Processor (via the DAC System) while monitoring for state changes at the output. The smallest incremental input change of the B REF TRIG LVL that produces an output change then defines the voltage point being measured (+ PEAK, -PEAK, or DC). When peak-to-peak voltage measurement is done, the Measurement Processor merely measures one peak voltage of the signal, then the other.

The output of the B Trigger Level Comparator is buffered by U442A and applied to the B Trigger input of U602 (Diagram 4) via delay line DL22. The 18 ns delay in the B Trigger signal path allows time for the Delay Time Comparator signal to enable the B Trigger System so that the B Sweep can be triggered on the same signal as the A Sweep.

Auxiliary Shift Register

Auxiliary Shift Register U1103 is the last register in Shift Register 1. Control bits loaded into the register from the AUX DATA signal line (from U303 pin 9, Diagram 5) are serially shifted through Sweep Shift Register U302 and U303 (Diagram 5). Circuit functions controlled by the bits in U1103 are the following:

B TV TRIG EN: Switches between the B TV Trigger signal and the DC measurement signal voltage (U1106C).

TV FIELD SEL: Switches the A Trigger between TV FIELD and TV LINE (U1104A).

MAG: Controls the X10 Magnification function of the Horizontal Output Preamp (U802, Diagram 6).

VERT COMP EN : Turns on the Vertical Comparator (U702, Diagram 2) during voltage self characterization.

TB CAL: Switches the time-base calibration signal into the B trigger system during horizontal self characterization (U1106A).

BW FULL B: Switches between full and limited B Trigger bandwidth.

BW LIMIT : Switches between full and limited A Trigger bandwidth. The **BW LIMIT** signal has a second use. As the last bit in Shift Register 1, it is fed back to the Measurement Processor during diagnostic checks done on the Shift Registers.

\overline{XY} : Switches the range of the horizontal position signal (HORIZ POS) between that needed for Y-T display and that needed for X-Y display (U301B, Diagram 6).

Multiplexer U1106A normally provides the Line Trigger signal picked off from the Power Supply input. For self characterization (SELF CAL) of the Time Base, the multiplexer outputs the TB CAL signal obtained from the Measurement Processor (U2501, Diagram 8).

TV Trigger Detector

INPUT AMPLIFIER. The signal at pin 20 of U421A is applied to pin 3 of U1101A via a low-pass filter formed by R426, L426, and C426. The filter limits the bandwidth of the X-AXIS signal to about 5 MHz for application to the Horizontal Preamp (U802, Diagram 6) and to the TV Trigger Detector circuitry. Operational amplifier U1101A provides low-pass gain of the applied composite video signal that further attenuates the video portion of the signal relative to the sync pulses. The output signal from U1101A is applied to the Peak Detectors and the Sync Comparator.

PEAK DETECTORS. The peak detectors determine the positive and negative peaks of the applied composite video signal. Those peak voltages are applied across a voltage divider circuit used to set the comparison level (slice level) to one input of a comparator. That level is such that, when the user selects the correct sync polarity for the applied signal, the middle of the sync tips is at the threshold level of the comparator. The output of the comparator then switches only on the sync tips of the applied signal. The peak detectors are complementary in that the positive-peak detector transistors (Q1101, Q1102, and Q1103) and the negative-peak detector transistors (Q1104, Q1105, and Q1106) are complementary types (PNP-NPN). Both detectors are driven from the same input signal; the positive peaks of the

video signal forward bias Q1101, and the negative peaks forward bias Q1104. The operation of the positive peak detector is described.

The composite video signal is applied to the emitter of Q1101. A positive-going signal increases the current through Q1101, causing the collector voltage to rise. The rising collector voltage biases on Q1102 harder, and C1114 charges up rapidly, following the positive-going signal up to its positive peak. When the input signal starts negative, Q1101 is turned off immediately by the charge held on C1114. That leaves C1114 holding the positive peak voltage of the input signal. Emitter-follower Q1103 applies that peak voltage level to U1104B pin 3 via R1117. R1136 to the -7.5 V from pin 3 provides a fixed offset to the signal level. The negative-peak detector does the same type of operation on the signal to apply the negative peak voltage to pin 5 of U1104B.

When the sync polarity is selected to match the sync of the applied video signal (by the user with the A SLOPE switch), the voltage level at the selected input of U1104B is at the middle of the sync-tip voltage. If the wrong polarity is selected, triggering will take place on the video signal. For signal generator signals, the effect may not be noticeable, except for a shift of the trigger point; but if composite video signals are being viewed, the display will be unstable when the wrong polarity is selected.

SYNC COMPARATOR. The incoming composite video signal is applied to the plus input (pin 3) of the Video Sync Comparator (U1102A). The Video Sync Comparator looks at the signal level on pin 2 and compares it with the incoming video signal level. When the incoming level crosses the comparison threshold, the output of U1102A switches state. That state change occurs at the mid level of the sync pulses. The output signal of U1102A (TV LINE) is applied directly to U1104A pin 2 and U1104C pin 1 to be available for selection for the A and the B Trigger systems for TV LINE triggering.

FIELD SYNC FILTER. The filter circuit composed of R1132, R1133, C1106, C1107, and U1102B processes the output of U1102A further to determine when the vertical field sync signal is present. The time constant of the filter elements is such that the line sync pulses between vertical fields cannot move the voltage on U1102B pin 5 across the comparison threshold (ground on pin 6).

During the vertical field sync pulse, the frequency of the serration pulses (line and equalizing) doubles. The filter capacitors will then be discharged enough to go below

ground and switch the output state of U1102B. That signal is applied to U1104A pin 1 to be available as the TV FIELD Sync trigger signal for the A Trigger system.

SYNC SWITCHING. Solid-state switches U1104A and U1104C provide switching between the TV FIELD and the TV LINE signal for the A Trigger and between TV LINE from A SOURCE and the average DC level of the measurement channel for the B Trigger. The switching states are controlled by the Measurement Processor via the TV FIELD SEL and the B TV TRIG EN control signals from the Auxiliary Shift Register (U1103).

DISPLAY AND TRIGGER LOGIC AND PROCESSOR INTERFACE (Diagram 4)

The Display Sequencer or SLIC (slow-logic integrated circuit, U600) performs most of the slow logic functions required to run the display functions. This integrated circuit contains a microprocessor interface, the display sequencer logic circuitry, the trigger holdoff timer, the chop clock, and an interface to the on-screen readout control logic.

The microprocessor interface of U600 provides the capability to serially load the internal control register, write the internal read/write memory, do some limited real-time control over a few sequencer functions, and monitor status information.

The Display Sequencer contains a read/write memory for storing the display states to be sequenced through and logic for sequencing the A and B Sweep displays and trigger sources. The sequencer also provides control signals that are needed to do waveform measurements.

An internal trigger holdoff timer provides a pulse with programmable width that is triggered on at the end of A Sweep (or at the end of B Sweep). The pulse width may be set from $1\ \mu\text{s}$ to greater than 0.5 s, depending on the internal counter divide ratio, and the holdoff oscillator frequency at pin 15.

The chop clock circuit generates a phase-dithered chop clock and blanking signal, derived from an external frequency source. With 10 MHz applied, the chop rate is 625 kHz, with a blanking time of about 200 ns.

The readout interface circuit responds to the readout request and readout blanking inputs, and generates a blanking signal (BLANK, pin 18) to control the Z-Axis Amplifier enabling signals from U602. The chop blanking signal also gets routed through this circuit.

Pin Description

The following is a description of Display Sequencer U600 pin functions (see Figure 3-2 for pin numbers).

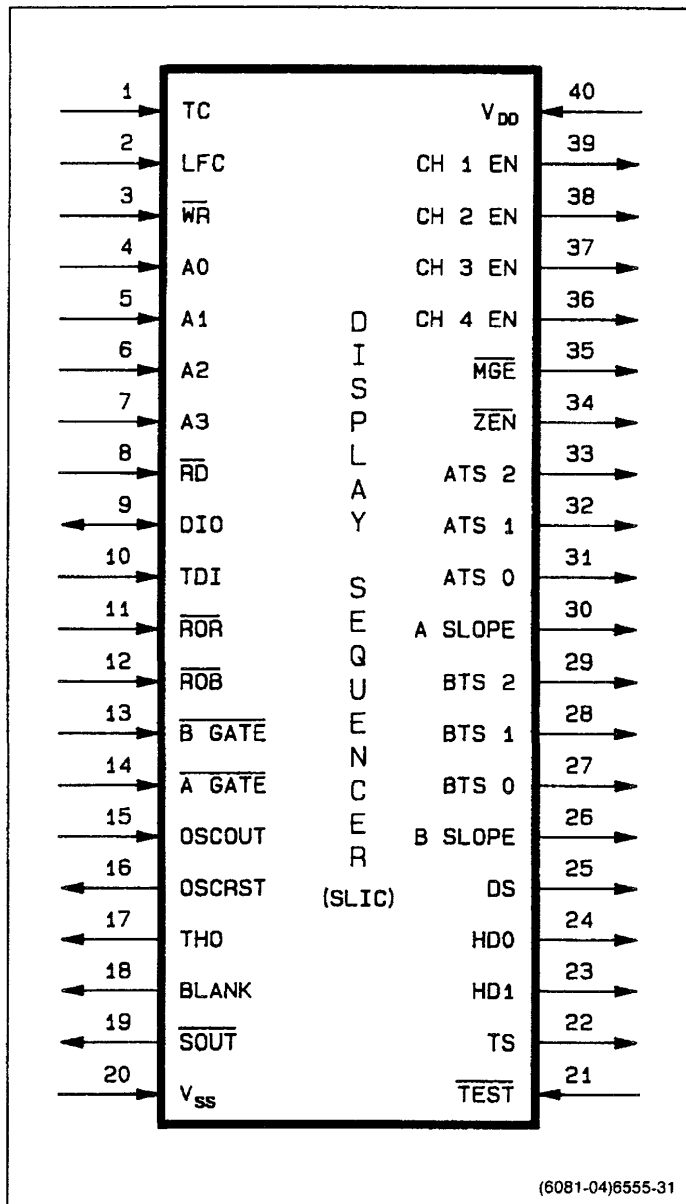

Figure 3-2. Display Sequencer IC (SLIC, U600) pin out diagram.

DIO: Data IO pin. This pin is tied to the Measurement Processor MB DATA line. Data to be clocked into the control register is presented here, and status data can be read out on this pin when the \overline{RD} input is low. See Table 3-7.

TDI: Trigger data input pin. When $A3 = A2 = 1$, data on this pin is sent to the DIO pin (when \overline{RD} is low).

\overline{RD} : Read enable input (active low). Bringing this pin low causes internal status data (selected with

$A3-A0$) to be presented on the DIO pin for transfer to the Measurement Processor.

\overline{WR} : Write enable input (active low). A negative-going pulse on this pin performs actions described in the Table 3-7.

\overline{SOUT} : Strobe output pin (active low). When $A3, A2, A1,$ and $A0 = 1111$, \overline{SOUT} goes low when the \overline{WR} pin is pulled low. Otherwise, \overline{SOUT} is always high.

$A3, A2, A1, A0$: Address inputs. The ADDR0-ADDR3 selection bits are latched from the Measurement Processor address bus by U2512, Diagram 8.

$\overline{A GATE}$: A Sweep Gate input (active low).

$\overline{B GATE}$: B Sweep Gate input (active low).

TC: Timing clock input.

LFC: Low-frequency clock input. A signal derived from the calibrator circuit is used for skewing the chop-clock phase.

\overline{ROR} : Readout request input (active low). A low causes the CH 1 EN, CH 2 EN, CH 3 EN, CH 4 EN, HD1, HD0, and TS outputs to all go low, and allows the \overline{ROB} input to have complete control of the BLANK output. If \overline{ROB} is low when \overline{ROR} goes low, then the internal timing will be such that the BLANK output will go high quickly enough to blank the display before switching transients can be shown on screen (see the detailed description of the readout interface).

\overline{ROB} : Readout blank input (active low). During readout active time ($\overline{ROR} = \text{low}$), the \overline{ROB} input is inverted and sent to the BLANK output.

OSC OUT: The external holdoff oscillator output drives this pin. A falling edge causes the internal holdoff counter to increment.

OSC RST: Oscillator reset output. Internal logic causes this output to go high to discharge the external holdoff oscillator timing capacitor at the end of holdoff (see detailed description of the holdoff timer operation).

CH 1 EN: Channel 1 enable output (active high).

CH 2 EN: Channel 2 enable output (active high).

CH 3 EN: Channel 3 enable output (active high).

CH 4 EN: Channel 4 enable output (active high).

Table 3-7
Display Sequencer (U600) Control Bit Assignments

A3	A2	A1	A0	DIO when \overline{RD} LO	Action when \overline{WR} Strobed
0	0	0	0	Control Reg. msb	DIO clocked into Control Reg. (a)
0	0	0	1	RAM comparator	RAM written from Control Reg.
0	0	1	0	EOSS flag	RAM address incremented (b)
0	0	1	1	EOS signal (c)	RESET is strobed (d)
0	1	0	0	A Gate Detect flag	MRESET is strobed (e)
0	1	0	1	B Gate Detect flag	RAM load mode enabled (f)
0	1	1	0	A Gate Detect flag	A/B GATE—detect flags reset
0	1	1	1	B Gate Detect flag	Set A slope output (g)
1	0	0	0	(h)	Forces B1/B2 Source/Slope/Delay (i)
1	0	0	1	(h)	Forces B Slope output (j)
1	0	1	0	(h)	Sets BLANK output HI (k)
1	0	1	1	(h)	Sets THO output HI (k)
1	1	0	0	TDI data	(see description of \overline{TEST} input)
1	1	0	1	TDI data	(see description of \overline{TEST} input)
1	1	1	0	TDI data	Sets norm B Source/Slope/Delay (l)
1	1	1	1	TDI data	\overline{SOUT} pin gets strobed

Notes:

- (a) Data is clocked into the control register on the rising edge of \overline{WR} .
- (b) RAM load mode must be enabled; the address increments on the rising edge of \overline{WR} .
- (c) EOS (end of sequence) goes high for the last state of any display sequence. EOS is read out for test purposes.
- (d) The THO output should be set high when RESET is strobed for proper initialization. This does the following:
- It initializes the display sequencer back to the first display state (RAM address 000). In ALT VERT Mode, all vertical enable, horizontal enable, and trig source outputs are initialized. In CHOP VERT Mode, the horizontal enable and trig source outputs are initialized, but the vertical enable outputs continue to cycle at the chop clock rate.
 - It resets the EOSS (end of single sequence) flag.
 - It resets the trigger holdoff timer.
- (e) Used for initialization, during testing of the device.
- (f) A rising edge on \overline{WR} with DIO = 1 enables the RAM load mode; a rising edge on \overline{WR} with DIO = 0 disables the RAM load mode.
- (g) A rising edge on \overline{WR} with DIO = 1 sets the A Slope output high; a rising edge on \overline{WR} with DIO = 0 sets the A Slope output low.
- (h) Used for device testing only.
- (i) A rising edge on \overline{WR} with DIO = 1 forces the B1 Trigger Source, the B1 Slope, and sets the DS output high; a rising edge on \overline{WR} with DIO = 0 forces the B2 Trigger Source, the B2 Slope, and sets the DS output low.
- (j) A rising edge on \overline{WR} with DIO = 1 forces the B SLOPE output high; a rising edge on \overline{WR} with DIO = 0 forces the B SLOPE output low. This forcing function takes precedence over the force B1/B2 Source/Slope/Delay feature described in note (i) above. This forcing function is canceled by applying a negative strobe to the \overline{WR} input with the address = 1110.
- (k) A rising edge on \overline{WR} with DIO = 1 sets the output high; a rising edge on \overline{WR} with DIO = 0 allows the output to behave normally. (l) A negative pulse on \overline{WR} with address = 1110 will cancel the effects of (i) above and allow the B Source, B Slope, and DS outputs to behave normally.

ATS 2, ATS 1, ATS 0: A Trigger Source Select outputs. These bits either correspond to three bits of the control register, or they track with the vertical channel enable outputs (in ALT Vertical Mode with VERT MODE trigger selected). These outputs change state on the rising edge of the THO output, or when RESET is strobed while THO is high. The encoding scheme is shown in Table 3–8.

Table 3–8
A Trigger Source Select Bits

ATS 2	ATS 1	ATS 0	SOURCE
0	0	0	CH 1
0	0	1	CH 2
0	1	0	CH 1 + CH 2
0	1	1	CH 3
1	0	0	CH 4
1	0	1	Line

A SLOPE: A Trigger slope output.

BTS 2, BTS 1, BTS 0: B Trigger Source Select outputs. These bits correspond to either one of two sets of three bits in the control register, or they can track with the vertical channel enable outputs (in ALT Vertical MODE). These outputs normally change state on the rising edge of the THO output, or when RESET is strobed while THO is high. If B1 or B2 Source/Slope/Delay is being forced, the outputs will correspond directly with one of the two three-bit sets in the control register. The encoding scheme matches that used for the A Trigger Source Select bits shown in Table 3–8.

B SLOPE: B Trigger Slope output. This output is set to either one of two bits in the control register. This output normally changes state on the rising edge of the THO output, or when RESET is strobed while THO is high. It may also be forced high or low by the Measurement Processor via the processor interface.

HD1, HD0: Horizontal display enable outputs. These outputs normally change state on the rising edge of the THO output, or when RESET is strobed while THO is high. The encoding scheme is shown in Table 3–9.

Table 3–9
Horizontal Display Mode Select Bits

HD1	HD0	SOURCE
0	0	Readout displayed
0	1	A Sweep displayed
1	0	B Sweep displayed
1	1	X–Y mode

DS: Delay select output. This output normally changes state on the rising edge of the THO output, or when RESET is strobed while THO is high. It may also be forced by the Measurement Processor via the processor interface. DS high selects the first delay (B1), and DS low selects the second delay (B2).

TS: Trace separation output. This output changes state on the rising edge of the THO output, or when RESET is strobed while THO is high. TS goes high to enable trace separation; TS goes low during a readout request cycle.

ZEN: Z–Axis enable output (active low). This output goes low when the ZAP control bit is set high, or when the selected B trigger source channel (as presented on the BTS 2, BTS 1, and BTS 0 output pins) is the same as the channel being enabled for display.

MGE: Measurement gate enable output (active low). This output behaves the same way as ZEN, except in chop vertical mode, in which MGE stays in a low state. Also, the ZAP control bit has no effect on MGE.

THO: Trigger holdoff output (active high). Outputs the variable holdoff pulse. In single sequence mode, this output will go high after the last A Sweep of the sequence and stay high until RESET is strobed. This output may also be forced high via the Measurement Processor interface.

BLANK: This output is controlled from three sources. At the end of a readout request cycle (when ROR goes high), the BLANK output will be asserted for four to six timing clock periods (to hide vertical source switching transients). Chop blanking pulses can be routed to this output (however, when ROR is low, chop blanking is automatically inhibited). Lastly, this output may be forced high via the Measurement Processor interface.

$\overline{\text{TEST}}$: Test mode enable input (active low). $\overline{\text{TEST}}$ is held high and not used in normal operation. This pin is pulled high to force normal operation, but may be pulled low to enable the test mode. Enabling test mode does the following:

1. Disables single sequence and B Ends A modes, no matter what code is in the control register.
2. Reconfigures the trigger holdoff timer to make it more easily testable (see control register description for control bits H4–H0).
3. A3, A2, A1, A0 = 1100 allows a negative-going pulse on $\overline{\text{WR}}$ to reset only the control register.
4. A3, A2, A1, A0 = 1101 allows a negative-going pulse on $\overline{\text{WR}}$ to preset control register bits B1–B6.

Control Register Description

The Display Sequencer internal control register is a 26-bit, serial-shift register that receives control-bit data from the Measurement Processor. Table 3-10 lists the control signal name(s) associated with each register bit. Bit number 1 receives the data from the DIO pin (via the Processor Interface) after one low-to-high transition on the $\overline{\text{WR}}$ input pin (A3 = A2 = A1 = A0 = 0). Bit number 26 receives this data after 25 more low-to-high transitions on the $\overline{\text{WR}}$ input. Bit number 26 is the most-significant bit position of the internal shift register.

RD5–RD0: Data inputs to the internal RAM. The RAM address comes from a three-bit, binary up-counter. To write data into the RAM, the first six bits are loaded into the control register with the RAM data word. With A3, A2, A1, A0 = 0001, a negative-going pulse on the $\overline{\text{WR}}$ input will write the data into RAM. To set the RAM address, the RAM load mode must be enabled. In RAM load mode, a low-to-high transition on the $\overline{\text{WR}}$ input (with A3, A2, A1, A0 = 0010) will increment the RAM address by one. There are eight consecutive RAM locations (addresses 000 to 111); the address counter will increment to 111, then wrap around to 000. Strobing RESET resets the counter to 000. See the Display Sequencer detailed description to find out what the RAM outputs do.

Table 3-10
Shift Register 1 Control Bit Data

Bit Nr	Control Signal Name(s)		
1	AS2	RD5	AC3
2	AS1	RD4	AC2
3	AS0	RD3	AC1
4	ZAP	RD2	AC0
5	B1S2	RD1	BC3
6	B1S1	RD0	BC2
7	B1S0		BC1
8	B1SLOPE		BC0
9	B2S2		
10	B2S1		
11	B2S0		
12	B2SLOPE		
13	VM1		
14	VM0		
15	HM1		
16	HM0		
17	DD		
18	SSE		
19	B ENDS A		
20	H4		
21	H3		
22	H2		
23	H1		
24	H0		
25	FSEL		
26	CBEN		

The RD5–RD0 bits also go to the inputs of an internal RAM comparator. The RAM outputs are sensed by the other comparator input. If the two inputs match, the comparator output will be high. The RAM comparator output can be read by the Measurement Processor through the processor interface.

AC3–AC0: The A Trigger coupling select bits. BC3–BC0 are the B Trigger coupling select bits. To write these bits into the trigger coupling circuits, the Measurement Processor loads the control register as follows: Bits 1, 2, 3, and 4 are set to AC3, AC2, AC1, and AC0 respectively. Bits 5, 6, 7, and 8 are set to BC3, BC2, BC1, and BC0 respectively. The RAM load mode is enabled and THO is strobed once (or

RESET is strobed once while THO is high). At this point, output pins ATS2, ATS1, ATS0, and A SLOPE are set to AC3, AC2, AC1, and AC0 respectively; and output pins BTS2, BTS1, BTS0, and B SLOPE are set to BC3, BC2, BC1, and BC0 respectively. The Measurement Processor then strobes the latches in the Trigger Coupling Select Logic circuits to make the trigger coupling selections. The RAM load mode is then disabled to resume normal Display Sequencer operation.

AS2, AS1, AS0: A Trigger SOURCE select bits. See Table 3-11 for the bit encoding of the control signals when not loading the RAM or coupling circuits.

For any binary code except 111; AS2, AS1, and AS0 are presented on output pins ATS2, ATS1, and ATS0 respectively after a THO rising edge. For binary code 111, the data on the three output pins will correspond to the channel being enabled for display; it alternates as the channel displays alternate and change state on the rising edges of THO. The RAM load mode is disabled to get the A Trigger SOURCE to alternate.

Table 3-11
Trigger Source Select

AS2	AS1	AS0	SOURCE
0	0	0	CH 1
0	0	1	CH 2
0	1	0	CH 1 + CH 2
0	1	1	CH 3
1	0	0	CH 4
1	0	1	Line
1	1	0	--
1	1	1	VERT MODE

ZAP: Setting this bit high forces the \overline{ZEN} output low. This bit is low for allow normal operation of the \overline{ZEN} output.

B1S2, B1S1, B1S0: B1 Trigger SOURCE select bits. Bit encoding is the same as the encoding for the A Trigger SOURCE select bits.

B2S2, B2S1, B2S0: B2 Trigger SOURCE select bits. Encoded the same as A Trigger SOURCE select bits, except that code 111 does not select VERT Mode trigger. Selection between B1 SOURCE and B2 SOURCE is normally made with the DS (delay select) output signal. DS = 1 selects B1, and DS = 0 selects B2. If the B1 select bits are 111 and the B1 SOURCE is selected (not forced), then the data on output pins BTS2, BTS1, and BTS0 will track with the selected vertical channel (similar to the A Trigger SOURCE select outputs).

B1 SLOPE, B2 SLOPE: B Trigger SLOPE bits. One of these two bits is presented on the B SLOPE output pin (if B SLOPE isn't being forced), in the same way that the B1 and B2 sources are selected. When B1 SOURCE is selected, then B1 SLOPE is also selected, and B2 SLOPE gets selected when B2 SOURCE is selected.

VM1, VM0: Vertical MODE control bits. See Table 3-12 for encoding.

Table 3-12
Vertical MODE Select

VM1	VM0	MODE
0	0	Not used
0	1	Chop Mode
1	0	Alt Mode (with no measurement)
1	1	Alt Mode (with measurement)

HM1, HM0: Horizontal MODE control bits. See Table 3-13 for encoding.

Table 3-13
Horizontal MODE Select

HM1	HM0	MODE
0	0	A only
0	1	ALT
1	0	B only
1	1	X-Y

Table 3-14
Holdoff Counter Encoding

H4	H3	H2	H1	H0	Count Length	H4	H3	H2	H1	H0	Count Length
0	0	0	0	0	1	1	0	0	0	0	10000
0	0	0	0	1	2	1	0	0	0	1	20000
0	0	0	1	0	5	1	0	0	1	0	50000
0	0	0	1	1	5	1	0	0	1	1	50000
0	0	1	0	0	10	1	0	1	0	0	100000
0	0	1	0	1	20	1	0	1	0	1	200000
0	0	1	1	0	50	1	0	1	1	0	500000
0	0	1	1	1	50	1	0	1	1	1	500000
0	1	0	0	0	100	1	1	0	0	0	100000
0	1	0	0	1	200	1	1	0	0	1	200000
0	1	0	1	0	500	1	1	0	1	0	500000
0	1	0	1	1	500	1	1	0	1	1	500000
0	1	1	0	0	1000	1	1	1	0	0	100000
0	1	1	0	1	2000	1	1	1	0	1	200000
0	1	1	1	0	5000	1	1	1	1	0	500000
0	1	1	1	1	5000	1	1	1	1	1	1 ^a

^a Strobing RESET presets the holdoff counter to 499999 to simplify testing.

DD: Dual-delay control bit. DD = 1 for dual delay (delta time), and DD = 0 for single delay.

SSE: SGL SEQ enable. SSE = 1 for single sequence mode or 0 for repetitive mode.

B ENDS A: B ends A enable (active high).

H4, H3, H2, H1, H0: Holdoff time. Encoded as in Table 3-14. With the TEST pin held high for normal operation.)

FSEL: Chop frequency select bit. With 10 MHz on the TC input pin, FSEL = 1 provides a chop frequency of 625 kHz; FSEL = 0 produces 1.25 MHz (625 kHz is used).

CBEN: Chop blank enable bit. CBEN = 1 allows the chop blanking signal to be passed out the BLANK output pin (when \overline{ROR} is high); CBEN = 0 inhibits chop blanking.

Display Sequencer Operation

The internal RAM is programmed for the desired vertical channel display sequence, for both CHOP and ALT Vertical Modes. In ALT mode, the RAM also controls the horizontal display control outputs. In CHOP mode, the RAM still controls the vertical channel displays, but different logic controls the horizontal display selection.

RAM data bits RD5, RD4, and RD3 are programmed for a particular channel display (see Table 3-15).

Table 3-15
Display Sequencer Channel Select Logic Bits

RD5	RD4	RD3	Channel
0	0	0	CH 1
0	0	1	CH 2
0	1	0	CH 1 + CH 2
0	1	1	CH 3
1	0	0	CH 4

Bit RD2 selects between the A Sweep display and the B Sweep display (only used in ALT Vertical Mode with measurement). The A Sweep is displayed if this bit is set high (outputs HD1, HD0 = 01), otherwise the B Sweep is displayed (outputs HD1, HD0 = 10). Bit RD1 controls the DS (delay select) output pin in ALT Vertical Mode (with or without measurement). Finally, bit RD0 marks the last state in a display sequence. When the RD0 bit goes high, the sequencer finishes its current state and jumps back to the initial state (RAM address 000 is the initial state). In ALT Vertical Mode, the sequencer will advance to the next state either on each rising edge of the trigger holdoff pulse (ALT Vertical Mode with measurement), or on every other rising edge of the trigger holdoff pulse (ALT Vertical Mode with no measurement).

The first type of ALT Mode is used when there is an intensified zone (with or without an accompanying B Sweep) for only one or two of the displayed channel(s); every display state can be completely specified by programming the RAM properly (no more than eight display states are ever needed for any measurement display sequence; hence, the RAM is limited to eight addresses). The second type of ALT Mode is used when there are intensified zones and B Sweeps for all channels displayed. In this mode, HD1 and HD0 automatically alternate between the A Sweep and the B Sweep on each rising edge of the trigger holdoff pulse. Whenever HD1 and HD0 switch from the B Sweep back to the A Sweep, the vertical sequencer advances to its next state. This second type of ALT Vertical Mode is used only when more than eight RAM locations are needed to define a long display sequence in ALT Horizontal Mode.

In ALT Vertical Mode, the vertical and horizontal display enable outputs are initialized as follows: the trigger holdoff output is forced high (via the processor interface), RESET is strobed, then trigger holdoff is reset to allow sweeps to occur. This procedure ensures that the display enable and trigger source outputs are initialized to the first state of the programmed display sequence.

In CHOP Vertical Mode, the leading edge of the chop blanking pulses advance the vertical display enable outputs. RAM bits RD5, RD4, and RD3 still determine the vertical channel displayed, and RAM bit RD0 marks the last display state in the sequence. RAM bits RD2, and RD1 are not used in CHOP Mode. Other circuitry, clocked by the trigger holdoff pulse, drives the horizontal display control outputs. The same initialization procedure as described above for ALT Vertical Mode is used. However, only the trigger source and horizontal display enable outputs are initialized. The vertical-display-enable outputs cycle at the CHOP rate. Table 3-16 specifies the behavior of the horizontal-display-enable outputs for all horizontal and vertical modes.

Trigger Holdoff Timer

When the B ENDS A control bit is low, the holdoff timer is triggered by the rising edge of $\overline{A\ GATE}$. When the B ENDS A control bit is high, the holdoff timer is triggered by either the rising edge of $\overline{B\ GATE}$, or the rising edge of $\overline{A\ GATE}$, whichever occurs first. The THO output pin will go high immediately, and go low after the programmed number of holdoff oscillator cycles. In SGL SEQ Mode (again, with the \overline{TEST} input pin high), the EOSS (end of single sequence) flag will go high and the THO output will stay high after the last A Sweep of the programmed sequence. Strobing RESET will reset the EOSS flag, and set the THO output back low again, if THO hasn't been forced high via the Measurement Processor interface.

HOLDOFF OSCILLATOR. A relaxation oscillator circuit formed by U601, Q600, Q601 and associated components is connected between the OSC OUT and OSC RST pins to provide the input count pulses to the holdoff timer. The HOLDOFF voltage applied to the base of Q600 sets up a charging current into timing capacitor C600. When the holdoff timer is inactive, the OSC RST output pin is high, and C600 is held discharged. With the capacitor discharged, the output of the oscillator is held high. When a rising edge of $\overline{A\ GATE}$ (or $\overline{B\ GATE}$ in B ends A mode) occurs, the OSC RST output will go low and allow the voltage across C600 to ramp up. When this voltage crosses an upper threshold, the output of U601 at pin 7 goes low. This negative transition increments the internal holdoff counter, and causes the OSC RST output to go high, again discharging C600. When the voltage drops below a lower threshold, the oscillator output again goes high to repeat the oscillation cycle. After the last negative transition on the OSC OUT pin for a particular count length, the OSC RST output will go high and stay there until the next time the THO timer is triggered.

Table 3-16
Horizontal and Vertical Display Response

Delay and Vertical Modes			HORIZONTAL CONTROL SIGNAL OUTPUTS					Readout Active ($\overline{\text{ROR}} = 0$)
			Signal Names	Readout Inactive ($\overline{\text{ROR}} = 1$)				
Horizontal Modes (HM1 HM0)								
A Only (0 0)	A Alt B (0 1)	B Only (1 0)		X/Y (1 1)				
DD	VM1	VM0						
0	0 or 0	0	NSSS (a)	1	2	1	(b)	(c)
			DS	HI	HI	HI	HI	(c)
0	0	1	HD0	HI	(d)	HI	LO	LO
			HD1	LO	$\overline{\text{FD0}}$	HI	HI	LO
			TS	LO	HD1	LO	LO	LO
1	0 or 0	0	NSSS (a)	2	4	2	(b)	(c)
			DS	(d)	(e)	(d)	LO	(c)
1	0	1	HD0	HI	(d)	LO	HI	LO
			HD1	LO	$\overline{\text{FD0}}$	HI	HI	LO
			TS	LO	HD1	LO	LO	LO
0	1	0	NSSS (a)	(f)	(f)	(f)	(b)	(c)
			DS	HI	HI	HI	HI	(c)
0	1	0	HD0	HI	(d)	LO	HI	LO
			HD1	LO	$\overline{\text{FD0}}$	HI	HI	LO
			TS	LO	HD1	LO	LO	LO
0	1	1	NSSS (a)	(g)	(g)	(g)	(b)	(c)
			DS	HI	HI	HI	HI	(c)
0	1	1	HD0	HI	(h)	LO	HI	LO
			HD1	LO	$\overline{\text{FD0}}$	HI	HI	LO
			TS	LO	HD1	LO	LO	LO
1	1	0	NSSS (a)	(f)	(f)	(f)	(b)	(c)
			DS	(i)	(i)	(i)	(i)	(c)
1	1	0	HD0	HI	(h)	LO	HI	LO
			HD1	LO	$\overline{\text{FD0}}$	HI	HI	LO
			TS	LO	HD1	LO	LO	LO
1	1	1	NSSS (a)	(g)	(g)	(g)	(b)	(c)
			DS	(h)	(h)	(h)	(h)	(c)
1	1	1	HD0	HI	(h)	LO	HI	LO
			HD1	LO	$\overline{\text{FD0}}$	HI	HI	LO
			TS	LO	HD1	LO	LO	LO

NOTES:

- (a) NSSS = Complete A Sweep cycles in a single sequence.
- (b) Not applicable in single sequence mode.
- (c) Signal state not affected by readout.
- (d) Signal changes state after each rising edge of THO; initialized to a high state in single sequence mode.
- (e) Signal changes state after every other rising edge of THO; it is initialized to a high state in SGL SEQ mode.
- (f) NSSS = Two times the number of states programmed into the vertical sequencer. In ALT Vertical Mode with no measurement, the vertical sequencer advances to its next state at the end of every other A GATE.
- (g) NSSS = The number of states programmed into the vertical sequencer.
- (h) Programmable with the vertical sequencer.
- (i) Programmable with the vertical sequencer. There are two A Sweeps per vertical display state.

Sweep Gate Detection

The Display Sequence IC (U600) also contains sweep gate detect latches that can be read out and reset via the Measurement Processor interface. The A GATE detect latch output will go high on the rising edge of $\overline{A\ GATE}$ after a falling edge of $\overline{A\ GATE}$, if the \overline{MGE} signal is low (i.e., the latch is armed by \overline{MGE}). The B GATE detect latch output goes high when $\overline{B\ GATE}$ goes low (level sensitive). The A GATE latch is reset on the leading edge of the A/B RESET signal, so that the latch will not miss an A GATE occurring before the end of the latch reset interval. The B GATE latch resets when the A/B RESET signal is low.

Chop Clock

The clock frequency applied to the TC input pin is either divided by 8 (FSEL = 0), or divided by 16 (FSEL = 1), producing a positive-going pulse at the BLANK output pin (when enabled) with a width equal to about two times the period of the clock signal on the TC input. To produce phase skewing, the chop frequency divider circuit is forced to skip ahead by four TC clock periods on a rising edge of $\overline{A\ GATE}$. This skipping is gated on and off by applying a low-frequency clock signal (about 1 kHz from the Calibrator circuit) to the LFC (low-frequency

clock) input pin. Internally, the LFC signal is divided by two, and when the resulting square wave is high, count skip-ahead is enabled.

Readout Interface

The Readout Interface accepts inputs from the \overline{ROR} and \overline{ROB} pins, and drives the BLANK output pin. When \overline{ROR} is high, the BLANK output is controlled by the chop blank signal (when enabled by the CBEN control bit).

When the \overline{ROR} input is low, chop blanking is disabled and the \overline{ROB} input is inverted and allowed to control the BLANK output. When the \overline{ROR} input goes from low to high, the BLANK output remains connected to the readout blank signal for an additional four to six TC clock periods. Normally, the \overline{ROB} input will be low during this time so that the BLANK output will be high to mask vertical source-switching transients. The HD1, HD0, and TS outputs are disabled two to four TC periods after \overline{ROR} goes low, and are again enabled two TC periods before the BLANK output is disconnected from the readout blank signal (\overline{ROB}). For any readout request cycle, the \overline{ROR} input remains low for greater than six TC clock periods. Relative timing of \overline{ROR} , BLANK, HD0 and HD1 (HDx), TS (trace separation), and vertical channel enables (CH x EN) is shown in Figure 3-3.

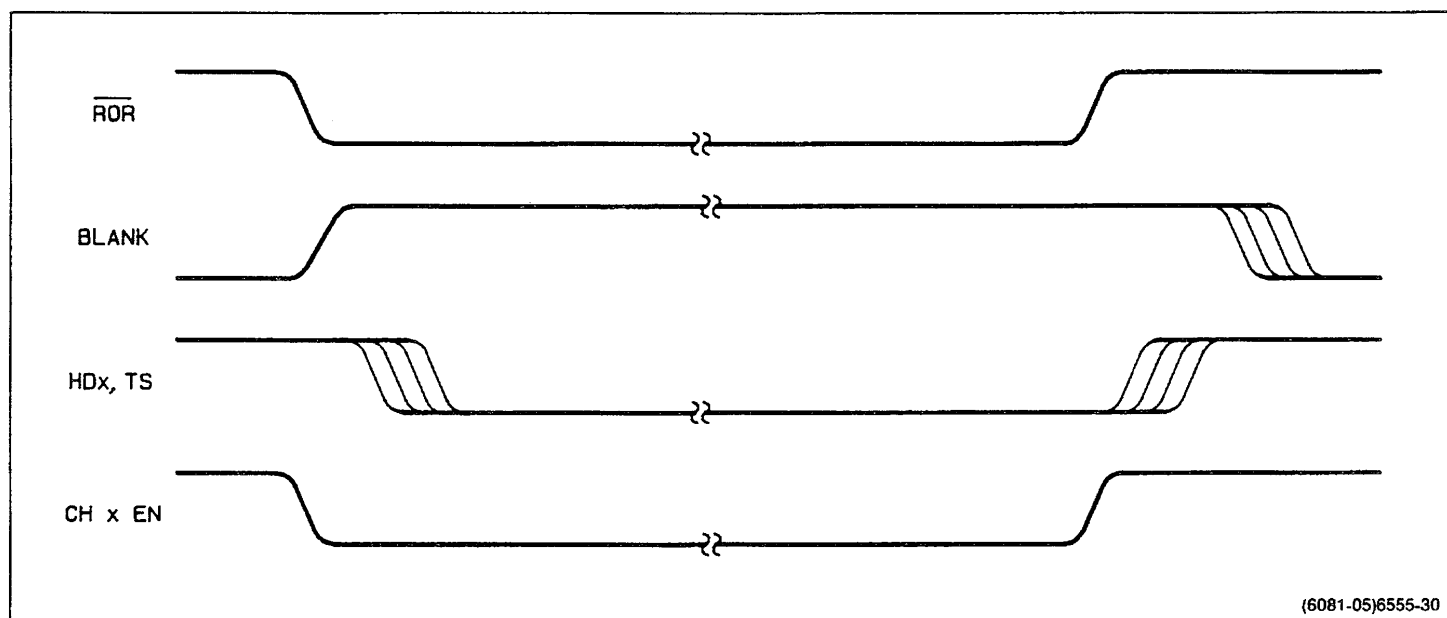

Figure 3-3. Readout interface relative signal timing.

Trigger Logic IC (FLIC)

The Trigger Logic IC or FLIC (fast-logic integrated circuit, U602 Diagram 4) does most of the fast logic functions required to run the oscilloscope. The functions are: A Sweep control, B Sweep control and measurement gate generation, Z-Axis control, and trigger status detection.

The A Sweep logic generates the A Sweep gate signal (A GATE), and provides trigger status information about the state of the A Trigger. The B Sweep logic interfaces to the Delay Time Comparators (Diagram 3) and generates the B Sweep gate (B GATE) and measurement gate signals. There is also some logic that monitors the B Trigger signal status when making voltage measurements with the B Trigger circuit. The Z-Axis control logic provides outputs for controlling the crt beam intensity.

The Trigger Logic circuit is done in an ECL (emitter-coupled logic) gate array, and all inputs and outputs are compatible with standard ECL components.

Pin Description

The following is a description of the fast logic pin outs (see Figure 3-4).

BLANK: Blanking input, from the Display Logic IC (U600).

HD1, HD0: Horizontal display select inputs, from the Display Logic IC.

ZEN: Z-Axis enable input, from the Display Logic IC. Active low.

BUSY: Counter/Timer busy signal.

ATRIG: A Sweep trigger input.

EOAS: End of A Sweep. This signal goes high when the A Sweep ramp crosses its end-of-sweep threshold.

THO: Trigger holdoff input from the Display Logic IC.

SIN: Strobe input. Latches data into the internal register. Active low.

A1, A0: Address inputs. See Table 3-17 for addressing codes.

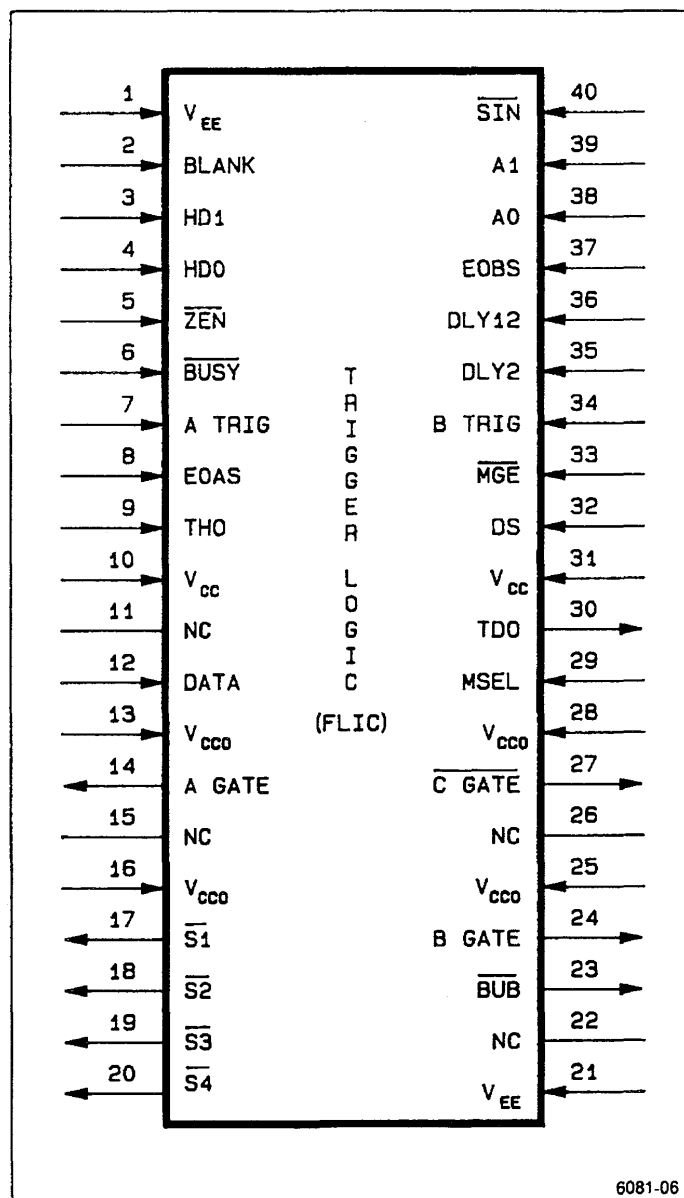

Figure 3-4. Trigger Logic IC (FLIC, U602) pin out diagram.

EOBS: End of B Sweep. This signal goes high when the B Sweep ramp crosses its end-of-sweep threshold.

DLY12: Input from first delay comparator. The comparator for the delay input switches from low to high after the end of either the first or the second sweep delay.

DLY2: Input from second delay comparator. This comparator normally switches from low to high after the end of the second sweep delay (in dual-delay mode).

B TRIG: B Sweep trigger input.

MGE: Measurement gate enable input from the Display Logic IC. Active low.

MSEL: Measurement select input. MSEL = 1 causes the DLY12 signal rising edges to sample the B TRIG input in strobed volts measurements. MSEL = 0 selects the DLY2 signal rising edges.

DS: Delay select signal from the Display Logic IC. DS = 1 selects first delay.

DATA: Data input to the internal, control shift register.

S1: Crt beam-intensity control output. Turns on the beam current for the A Sweep displays. Active low.

S2: Crt beam-intensity control output. Turns on the beam current for the B Sweep displays. Active low.

S3: Crt beam-intensity control output. Turns on the beam current for the A Sweep intensified zone displays. Active low.

S4: Crt beam-intensity control output. Turns on the beam current for the Readout displays. Active low.

A GATE: A Sweep gate output. Starts the A Sweep ramp. Active high.

TDO: Trigger data output. Data to be read is selected via the A1 and A0 inputs (see Table 3-17).

B GATE: B Sweep gate output. Starts the B Sweep ramp. Active high.

BUB: B Sweep unblanking output. Active low.

C GATE: Measurement gate output. Used in gated measurements to arm the Counter/Timer. Active low.

Table 3-17
Trigger Logic IC Addressing Logic

A1	A0	Output of TDO pin	Action when $\overline{\text{SIN}}$ Strobed
0	0	Strobed Volts Latch	DATA clocked into Control Reg
0	1	Auto baseline Latch	Resets Auto base-line Latch
1	0	A Trigger Latch	Resets A Trigger Latch
1	1	Peak Volts Latch	Resets Peak Volts Latch

Trigger Logic IC Control Register Description

The control register of U602 is an 8-bit shift register that receives input from the DATA pin. Bit 1 receives the data on a low-to-high transition on the $\overline{\text{SIN}}$ pin (A1 = A0 = 0). Bit 8 receives this data after seven more low-to-high transitions on the $\overline{\text{SIN}}$ pin. Bit 8 is the msb of the control register. Table 3-18 lists the control signal name associated with each control register bit.

Table 3-18
Control Register Signal-bit Names

Bit	Name
1	DM0
2	DM1
3	BRUN
4	PM0
5	PM1
6	ZM0
7	ZM1
8	ARUN

DM1, DM0: These bits select the delay mode (see Table 3-19).

BRUN: This bit determines whether the B Sweep is in RUNS AFTER delay mode or Triggered After delay mode. BRUN = 1 selects RUNS AFTER Mode.

PM1, PM0: These bits select the peak volts detection mode as shown in Table 3-20.

Table 3-19
Delay Mode Selection Control Bits

DM1	DM0	Delay Mode
0	0	First delay set to zero
0	1	First and second delays set to zero
1	0	Normal delay mode
1	1	B Sweep disabled

Table 3-20
Peak Volts Detection Mode Logic

PM1	PM0	Peak Detection Mode
0	0	Nongated
0	1	Gated from end of delay to end of A Sweep
1	0	Gated with $\overline{C\ GATE}$
1	1	Gated with A GATE

ZM1, ZM0: These bits determine the intensified zone mode. See the Z-Axis logic discussion.

ARUN: This bit determines whether the A Sweep is in the free-run mode or in the triggered mode. ARUN = 1 selects the free-run mode.

A Sweep Logic

When ARUN is high, the A Sweep logic works as follows. A high on the THO input causes the A GATE output to go low. As soon as THO goes low, the A GATE output will go high and the A Sweep runs. At the end of the A Sweep there is a low-to-high transition on the EOAS input. That sets the the internal end-of-A-sweep latch, causing the A GATE output to go low, and the A Sweep shuts off. This state exists during sweep retrace and the baseline stabilization period until the end of holdoff when the THO input once again goes high. That resets the end-of-A-sweep latch and starts another A Sweep cycle. Normally, the falling edge of A GATE will cause an externally generated pulse to be presented on the THO input, thus completing the loop and allowing the A Sweep to free-run (auto-level and auto triggered mode when the sweep is not triggered).

When ARUN is low, the operation is similar except that after a pulse on the THO input, A GATE won't go high

until a low-to-high transition is presented on the A TRIG input (triggered sweep mode).

For either free-run or triggered modes, THO going high will cause the A GATE output to immediately go low, if the end-of-A-Sweep latch is set or not. Once the end-of-A-Sweep latch has been set, no more A Sweeps can happen until the THO input is pulsed (at the end of the holdoff). The end-of-A-Sweep latch can only be set with the EOAS input when A GATE is high.

The A Sweep logic of U602 also monitors the A TRIG input to latch certain A Trigger events. One latch (the auto-baseline latch) will set on any low-to-high transition on the A TRIG input. Another latch (the A Trigger latch) is level sensitive and will set when the A TRIG input is high. Both latches may be read out through the TDO (trigger-data out) pin, selected by the A1 and A0 address input pins. That data is applied to the TDI (trigger data in) pin of U600 and placed in the Display Logic IC's internal register to be read by the Measurement Processor. Both latches may also be reset via the \overline{SIN} pin (see description of A1, A0, and \overline{SIN} input pins).

B Sweep Logic

The B Sweep logic functions about the same as the A Sweep logic, except that more signals must be monitored to determine when the B Sweep can run. When DM1 and DM0 = 11, the B Sweep can't run at all. When DM1 and DM0 = 10, the B Sweep won't be allowed to run or trigger until the DLY12 input goes high while the A GATE signal is also high (the normal delayed sweep mode). When DM1 and DM0 = 01, the B Sweep will be allowed to run or trigger immediately after the A GATE signal goes high (no B Sweep delay). When DM1 and DM0 = 00, then the B Sweep will be allowed to run or trigger immediately after the A GATE signal goes high, if the DS (delay select) input is high. If DS is low, the B Sweep is allowed to run or trigger as soon as the DLY12 input goes high while the A GATE signal is also high.

The B Sweep logic behaves as follows. The B GATE signal goes high and \overline{BUB} (B Sweep unblanking) goes low together when the appropriate conditions (described in the preceding paragraph) are met. A low-to-high transition on the EOBS input will then set the end-of-B-sweep latch, causing \overline{BUB} to go high. B GATE doesn't go low until the A GATE signal goes low. This is used internally to generate the $\overline{S2}$ and $\overline{S3}$ outputs in some modes, and is used externally to carry out the B ends A mode.

The DLY12 input goes to a level-sensitive latch; if A GATE is high and DLY12 momentarily goes high, the

latch will be set, so that the DLY12 input does not need to be held high throughout the sweep cycle. A high level on the THO input will cause the A GATE signal to go low. That resets this latch and causes the reset of the rest of the sweep logic, forcing B GATE low and $\overline{\text{BUB}}$ high.

The DLY2 input also goes to a level sensitive latch. This second latch also gets reset when A GATE goes low. Together with the DLY1 latch output, A GATE, and the $\overline{\text{MGE}}$ input, the $\overline{\text{C GATE}}$ output signal gets generated. $\overline{\text{C GATE}}$ goes low if A GATE is high, the DLY1 latch has been set, the DLY2 latch is still reset, and the $\overline{\text{MGE}}$ input is low.

Peak Volts Logic

The peak volts logic detects the positive and negative peaks of the B TRIG signal. It consists of a level-sensitive latch that can be gated by the $\overline{\text{C GATE}}$ signal, the A GATE signal, the DLY12 latch output, or continuously. The latch may be reset by strobing the $\overline{\text{SIN}}$ input with A1 and A0 set to 11. The latch output can be read at the TDO pin with A1 and A0 set this way. The Measurement Processor reads the state of the peak volts latch to determine when it has found the correct digital value of the signal peak being measured by the B Trigger Level Comparator.

The peak-detect latch output will go high when the B TRIG input goes high (if the gating condition selected by PM1 and PM0 is satisfied). The latch output goes low when reset.

Strobed Volts Logic

This logic samples the state of the B TRIG signal with the delay comparator outputs when making gated voltage measurements. The strobed volts latch consists of an edge-triggered flip-flop with a multiplexer driving the clock input, and the B TRIG signal driving the D input. When MSEL = 1, the DLY12 latch output clocks the flip-flop. When MSEL = 0, the DLY2 latch output clocks the flip-flop. The state of the flip-flop is read out at the TDO pin by the Measurement Processor when A1, A0 = 00. The flip-flop is reset by strobing the $\overline{\text{SIN}}$ input with A1, A0 = 11.

Z-Axis Logic

This logic drives the Z-Axis control outputs ($\overline{\text{S1}}$ - $\overline{\text{S4}}$). These outputs have the following control action:

$\overline{\text{S1}}$ Turns on the A intensity current switch (active low).

$\overline{\text{S2}}$ Turns on the B intensity current switch (active low).

$\overline{\text{S3}}$ Turns on the A intensified current switch (active low).

$\overline{\text{S4}}$ Turns on the Readout intensity current switch (active low).

Table 3-21 describes what the $\overline{\text{S1}}$ - $\overline{\text{S4}}$ outputs do as a function of ZM1, ZM0, HD1, HD0, $\overline{\text{A GATE}}$, $\overline{\text{BUB}}$, $\overline{\text{C GATE}}$, $\overline{\text{BUSY}}$, BLANK, and $\overline{\text{ZEN}}$.

ECL-to-CMOS Level Shifters

The Trigger Logic IC, U602, is an ECL device. Its output signal swing is the standard ECL range of about 0.6 V. All the ECL logic devices in the 2247A are powered from the +5 V supply rather than a -5 V supply. The resulting output voltage swing is from about 4.5 V to about 3.9 V between the high and low ECL logic levels. As U602 must pass signals to the Display Sequencer IC (U600) at CMOS highs and lows (about 3.9 V and 0 V respectively in this application), logic level translators are required. That job is done by an identical translator circuit for each of the three signals that must be sent. The circuit action of U603C, Q604, and Q605 (the $\overline{\text{A GATE}}$ translator) is described.

The single-ended A GATE output signal of U602 at pin 14 is applied to pin 10 of U603C. With its other input pin left open, U603C is used as a line driver only to produce a differential output signal. That differential signal is applied to the bases of a differential amplifier pair of pnp transistors (Q604 and Q605). The output signal is taken across R612 in the collector of Q604. The collector of Q605 is connected directly to ground. When the A GATE output of U602 is high (at 4.5 V), the voltage applied to the base of Q604 is 4.5 V, and the voltage on the base of Q605 is 3.9 V. These voltage levels bias Q605 on and Q604 off, with a resulting output level across collector resistor R612 of 0 V to the $\overline{\text{A GATE}}$ (active low) input of U600. When the A GATE output of U602 goes low at the end of the sweep, the bias voltage levels on Q604 and Q605 reverse, and Q604 is biased on (and Q605 off). Signal current through collector resistor R612 develops a voltage of about 3.9 V (the unasserted level) to the $\overline{\text{A GATE}}$ input of U600.

Display Logic Clock

The Display Logic clock signal at 10 MHz is generated by a transistor oscillator circuit composed of Q608, Y600, and associated components. The frequency of oscillation is controlled by a ceramic resonator, Y600, in the feedback path from the collector to the base of Q608.

Table 3-21
Z-Axis Switching Logic

ZM1	ZM0	HD1	HD0	$\overline{S1}$	$\overline{S2}$	$\overline{S3}$	$\overline{S4}$	Display Mode
0	0	0	0	1	1	1	(c)	Readout
0	0	0	1	(a)	1	(e)	1	A Sweep intensified by BUSY
0	0	1	0	1	(b)	1	1	B Sweep
0	0	1	1	(c)	1	1	1	X/Y
0	1	0	0	1	1	1	(c)	Readout
0	1	0	1	(a)	1	(d)	1	A Sweep intensified by C GATE
0	1	1	0	1	1	1	1	Blank
0	1	1	1	(c)	1	1	1	X/Y
1	0	0	0	1	1	1	(b)	Readout
1	0	0	1	(a)	1	(b)	1	A Sweep intensified by BUB
1	0	1	0	1	(b)	1	1	B Sweep
1	0	1	1	(c)	1	1	1	X/Y
1	1	0	0	1	1	1	(c)	Readout
1	1	0	1	(a)	1	1	1	A Sweep no intensified zone
1	1	1	0	1	1	1	1	Blank
1	1	1	1	(c)	1	1	1	X/Y

NOTES:(a) = BLANK or $\overline{A\ GATE}$ (b) = BLANK or $\overline{A\ GATE}$ or \overline{BUB} or \overline{ZEN}

(c) = BLANK

(d) = BLANK or $\overline{A\ GATE}$ or $\overline{C\ GATE}$ or \overline{ZEN} (e) = BLANK or $\overline{A\ GATE}$ or \overline{BUSY} or \overline{ZEN}

A AND B SWEEPS AND DELAY COMPARATORS (Diagram 5)

Sweep Control Shift Registers

Two serial shift registers provide the control interface between the Measurement Processor and the A and B Sweep circuitry. Control bits loaded into registers U302 for A Sweep and U303 for B Sweep are serially clocked from the SR DATA line by the SR1 CLK pulse. The states of the loaded bits select the A and B Sweep timing by choosing the correct charging current and timing capacitor to provide the full range of sweep speeds. Other control bits loaded into the two registers select the delay voltage applied to the Delay Comparators and the output voltage from the VOLTS CAL circuit (used for measurement SELF CAL). Extra bits are shifted through the two shift registers into the Auxiliary Data Register (U1103, Diagram 3) via the AUX DATA signal line to

control the trigger bandwidth, the TV Sync Detector switching, and the functions of 10X MAG, X-Y display, and Vertical Comparator enabling.

A and B Sweep Timing

Refer to Figure 3-5 for a simplified schematic of the A Sweep circuitry.

TIMING RESISTORS. The Sweep Timing resistors in resistor pack R313 are shared between the A Sweep and the B Sweep circuitry; those in resistor pack R321 are divided between the two sweep circuits. Timing Resistor selection is done by multiplexers U308 and U307 for the A Sweep and by U310 and U311 for the B Sweep. The multiplexers are driven by the Measurement Processor via control bits loaded into Shift Register 1 (U302 and U303). (See Table 3-22 for the control bit coding.)

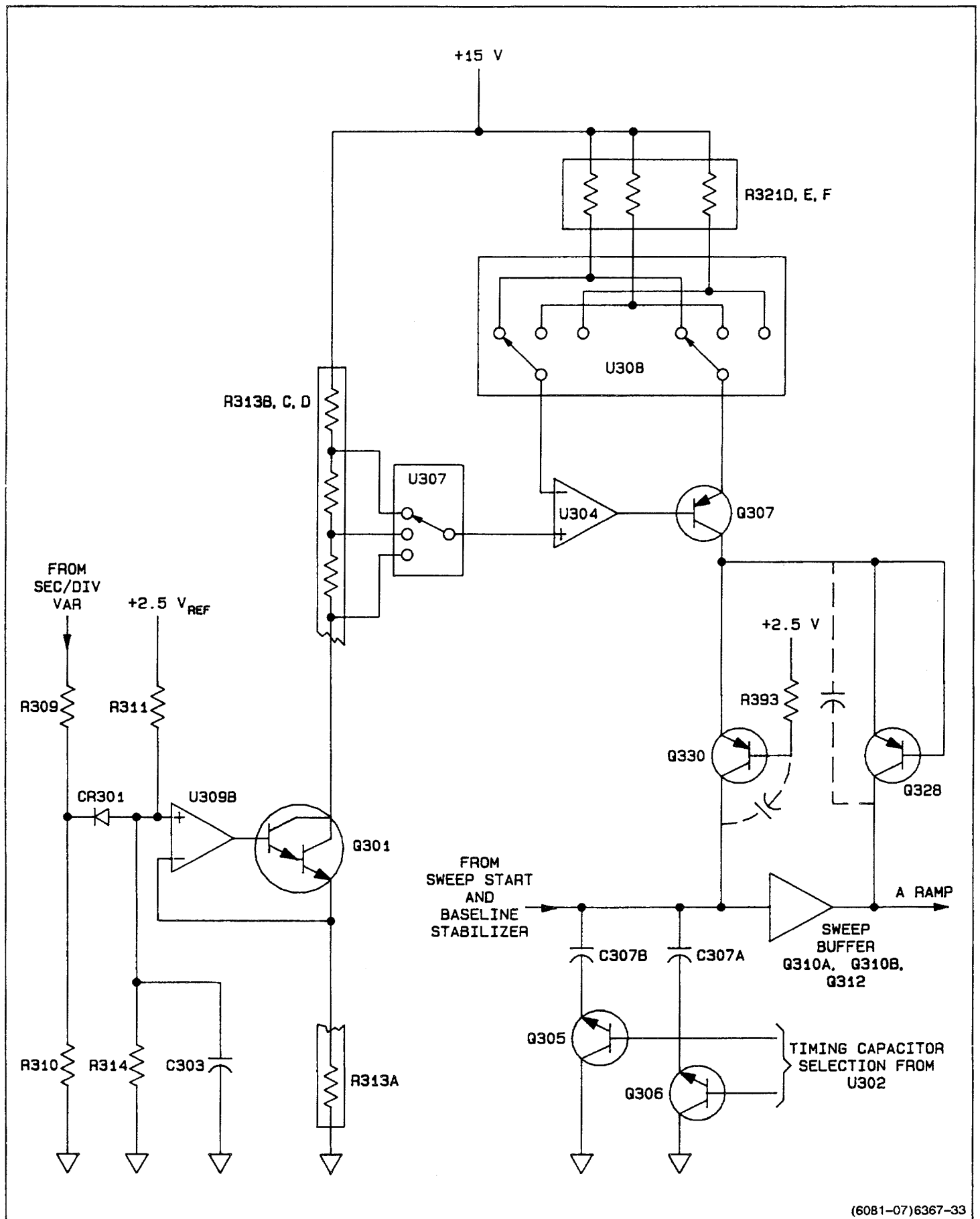

(6081-07)6367-33

Figure 3-5. Simplified Sweep Circuit.

SEC/DIV VAR CIRCUIT. Variable sweep speed is controlled by the TIME VAR voltage applied to operational amplifier U309B. The amplifier controls the current passing through Darlington transistor Q301 to the voltage divider formed by resistor pack R313. The voltages at the taps of the voltage divider set the forward bias on the charging-current pass transistor, Q307, via operational amplifier U304. When the SEC/DIV VAR control is in its detent (calibrated) position, diode CR301 is reverse biased, and the divider formed by R311 and R314 between the +2.5 V reference and ground precisely sets the input voltage to the noninverting input of U309B. With a fixed voltage output from U309B, the current through Q301 and R313 is also a fixed value. When the SEC/DIV VAR control is rotated out of its detent position, the voltage at the junction of R309 and R310 decreases to forward bias CR301. The input voltage to U309B and, therefore, the current to R313 decreases in proportion to the amount of rotation of the SEC/DIV VAR control. A decreasing voltage at the output taps of R313 decreases the charging current through Q307 to increase the sweep ramp time.

A AND B SWEEP TIMING CAPACITORS. The timing capacitor selection circuitry is similar for the A and the B Sweep, but the B Sweep has fewer range steps and doesn't require two selectable capacitors. Only the A Sweep timing capacitor selection is described; like components in the B Sweep circuit do the same job.

Timing capacitance for the A Sweep is made up of a combination of fixed, variable, stray, and selectable components. Sweep timing for the fastest A Sweep speeds is done with a combination of the fixed, variable, and stray capacitance and the selectable charging current supplied through R321, U308, Q307 and Q330. When the slower sweep speeds are selected, additional capacitors must be switched into the circuit to produce a longer charging time. The capacitors that are always in the A Sweep charging path are C315 (a fixed capacitor), C314 (a variable capacitor used to adjust the A Sweep timing at the fastest sweep speeds), and the stray circuit capacitance.

The base-to-collector junction capacitance of Q330 changes as the voltage between the base and collector of Q330 increases during ramp up. At the fastest A Sweep speeds, that change would affect the timing at the start of the charging ramp. To compensate for the junction-capacity effect of Q330, transistor Q328 (connected as a diode) is added between the charging current path and the A Sweep Buffer output. The capacitive current through the reverse-biased junction of Q328

adds current to the output to make up for the current required to charge the base-to-collector capacity of Q330 in the input of the Sweep Buffer.

The selectable sweep timing capacitors come in a matched set of three capacitors, two for the A Sweep timing (C307A and C307B) and one for the B Sweep timing (C307C). When added capacitance is needed for a sweep speed setting, the Measurement Processor loads selection control bits into Shift Register 1 (U302 for the A Sweep) that turn on either Q305 or Q306 or both. Assume that Q305 is biased on by a high control bit from pin 5 of U302. Capacitor C307B is then added in parallel to the capacitors in the charging path, and a longer ramp time is needed to reach the end-of-sweep voltage level. Control bits selecting the charging current are also loaded at the same time. See Table 3-22 for the A Sweep timing and control bit selections (as0-as5) and Table 3-23 for the B Sweep bit selections (bs0-bs4).

Baseline Stabilizer

The job of the Baseline Stabilizer circuit (Q302, Q303, and Q304 for the A Sweep and Q315, Q316, and Q317 for the B Sweep) is to tie the start of the sweep ramps to the same fixed level for each sweep. Operation of the A Sweep stabilizer is described.

A differential circuit formed by Q302 and Q303 compares the A Sweep feedback signal on the base of Q303 against the reference voltage on the base of Q302, to control the base bias current to Q304 and thereby the sweep baseline level. Operational amplifier U309A generates the fixed reference that the baseline voltage level is compared against. The reference voltage amplifier has a gain of -0.8 (less than one and inverted); and, with +2.5 V applied to the inverting input and the non-inverting input grounded, the output level is -2 V. Capacitor C305 filters the output to eliminate noise that could cause sweep start jitter. The filtered voltage is applied to the junction of R317, R354, and C305 and references both Baseline Stabilizer circuits.

A and B Sweep Start

The A and B Sweep Start circuits operate the same way with like components in each doing the same job; only the A Sweep Start circuit is described. Sweep time may be divided into three periods: baseline, run-up, and retrace (see Figure 3-6). Sweep start and length of sweep run-up is controlled by the A GATE and A GATE signals from the Trigger Logic IC (U602, Diagram 4).

Table 3-22
A Sweep Timing Selections

SPEED	I _{timing}	C _{timing}	as0	as1	as2	as3	as4	as5	Min H.O.
20 ns	2 mA	C314/C315	0	0	1	1	1	0	2.0 μ s
50 ns	800 μ A	"	0	0	0	0	1	0	2.0 μ s
100 ns	400 μ A	"	0	0	1	0	0	1	2.0 μ s
200 ns	200 μ A	"	0	0	0	1	0	1	2.0 μ s
500 ns	80 μ A	"	0	0	0	0	0	1	2.0 μ s
1 μ s ^a	40 μ A	"	0	0	1	0	0	0	2.0 μ s
2 ms ^a	20 μ A	"	0	0	0	1	0	0	4.0 μ s
5 μ s ^a	8 μ A	"	0	0	0	0	0	0	10 μ s
1 μ s	4 mA	C307B	0	1	1	0	1	0	2.0 μ s
2 μ s	2 mA	"	0	1	0	1	1	0	4.0 μ s
5 μ s	800 μ A	"	0	1	0	0	1	0	10 μ s
10 μ s	400 μ A	"	0	1	1	0	0	1	20 μ s
20 μ s	200 μ A	"	0	1	0	1	0	1	40 μ s
50 μ s	80 μ A	"	0	1	0	0	0	1	100 μ s
100 μ s	40 μ A	"	0	1	1	0	0	0	200 μ s
200 μ s	20 μ A	"	0	1	0	1	0	0	400 μ s
500 μ s	8 μ A	"	0	1	0	0	0	0	1.0 ms
1 ms	4 mA	C307A	1	0	1	0	1	0	2.0 ms
2 ms	2 mA	"	1	0	0	1	1	0	4.0 ms
5 ms	800 μ A	"	1	0	0	0	1	0	10 ms
10 ms	400 μ A	"	1	0	1	0	0	1	20 ms
20 ms	200 μ A	"	1	0	0	1	0	1	40 ms
50 ms	80 μ A	"	1	0	0	0	0	1	100 ms
100 ms	40 μ A	"	1	0	1	0	0	0	200 ms
200 ms	20 μ A	"	1	0	0	1	0	0	400 ms
500 ms	8 μ A	"	1	0	0	0	0	0	1 s

^aUsed only during horizontal characterization.

A GATE SIGNALS. The A GATE and $\overline{\text{A GATE}}$ signals are applied via 8.2 V zener diodes (VR301 and VR302) to the bases of Q308 and Q309 in a differential amplifier configuration. The input circuit to the differential pair level shifts the ECL signals (4.3 V to 3.4 V) to the proper biasing levels (-3.9 V to -4.8 V) for the bases of the

differential amplifier transistors. Transistor Q326 in the emitter circuit of Q308 and Q309 is the current source for the differential pair. Transistor Q311 is part of the bias circuit for Q326 and provides feedback to the base of Q326 that controls the current provided to Q308 while the sweep is being held at the baseline level.

Table 3-23
B Sweep Timing Selections

SPEED	I _{timing}	C _{timing}	bs0	bs1	bs2	bs3	bs4
20 ns	2 mA	C329/C330	0	1	1	1	0
50 ns	800 μ A	"	0	0	0	1	0
100 ns	400 μ A	"	0	1	0	0	1
100 ms	200 μ A	"	0	0	1	0	1
100 ms	80 μ A	"	0	0	0	0	1
1 μ s	40 μ A	"	0	1	0	0	0
2 μ s	20 μ A	"	0	0	1	0	0
5 μ s	8 μ A	"	0	0	0	0	0
10 μ s	4 mA	C307C	1	1	0	1	0
20 μ s	2 mA	"	1	0	1	1	0
50 μ s	800 μ A	"	1	0	0	1	0
100 μ s	400 μ A	"	1	1	0	0	1
100 μ s	200 μ A	"	1	0	1	0	1
100 μ s	80 μ A	"	1	0	0	0	1
1 ms	40 μ A	"	1	1	0	0	0
2 ms	20 μ A	"	1	0	1	0	0
5 ms	8 μ A	"	1	0	0	0	0

BASELINE STATE. In the baseline state (during sweep holdoff), Q308 and Q304 are on and Q309 is off, and the level at the collector of Q308 is held at -2.8 V. That voltage is buffered by the A Sweep Buffer (with about a 0.7 V rise across the base-to-emitter junction of Q312) and fed back to the base of Q303 where it is compared with the -2 V reference produced by operational amplifier U309A. If the baseline voltage is too low compared to the output of U309A, Q303 (the retrace current regulator) is biased on a little harder. Additional base current is available to Q304, and it conducts harder to raise the output baseline voltage to the reference voltage level. The opposite action occurs if the baseline voltage is too high.

A smaller feedback loop formed by Q311 and R305 controls the gain of Q326 so that the standing current available (about 3 mA) is just enough to keep Q304 biased on during the baseline state. When the states of the gate signals reverse, Q309 is turned on and Q308 turns off. The standing current then conducts through

Q309 to rapidly pull the base of Q304 down to shut it off. When the base voltage reaches about -2.7 V, Q333 conducts. That action clamps the base voltage of Q304 (and the collector voltage of Q309) at that level and prevents Q309 from saturating so that it will have a short turn-off time when the sweep ends.

RUNUP STATE. With Q304 and Q308 off, the charging current from the timing circuit can begin charging the timing capacitors, and the voltage at the emitter of Q304 ramps up linearly. That ramp is buffered by the A Sweep Buffer (U310A and B and Q312) to drive the Horizontal Output Amplifier. As the ramp is running up, it is being compared with a fixed reference level by the Sweep End Comparators. When the ramp level reaches the comparison level, the A SWP END signal goes high. That signals the Trigger Logic IC, U602, to end the A GATE signal, and the sweep is switched to the retrace state. The sweep ramp is also being fed back to the base of Q303. At the point in the ramp that the base voltage of Q303 exceeds that on the base of Q302 (the -2 V baseline reference), Q303 is biased off and Q302

conducts. This biasing conditions disables the feedback loop that stabilizes the baseline voltage level, and it remains off until the feedback voltage during the retrace period falls back to near the -2 V baseline reference voltage on the base of Q302.

RETRACE STATE. At the end of the sweep, the gate signals reverse state. Transistor Q309 is biased off, and Q308 is biased on. Retrace current supplied by Q308 quickly returns the voltage across the timing capacitor to a little below the baseline voltage level. That retrace current is regulated by Q311 and Q326 to produce a rapid, yet rate-controlled retrace. At the point of the fall in feedback voltage where Q303 starts to turn on, base current becomes available to Q304 to turn it on, and the feedback loop that stabilizes the voltage at the baseline level again becomes active.

A and B Sweep Buffers

The A Sweep Buffer (Q310A and B, and Q312) and B Sweep Buffer (Q323A and B, and Q325) buffer the voltage ramp as the timing capacitors charge. In the A

Sweep circuit, Q310A is a high-impedance source follower driving emitter-follower Q312. The output signal from the emitter of Q312 is applied to the Delay Time Comparators and the End-of-Sweep Comparators, fed back to the Baseline Stabilizer circuit, and sent to the Horizontal Output Amplifier (Diagram 6) as the A RAMP horizontal deflection signal.

Sweep End Comparators

The sweep ramp signals must horizontally deflect the electron beam across the entire face of the crt. Comparators U316A, B, C, and D determine when the A and B Sweeps have reached the required amplitude. These comparators check the sweep voltage against the reference level that defines the end of the sweep and generate the A SWP END and B SWP END signals when that level is reached. The sweep-end signals are applied to the Trigger Logic IC (U602) so that device knows when the sweeps are done. The Trigger Logic IC then switches the states of the A GATE or the B GATE signal (as appropriate) to reset the sweep circuitry to its baseline level.

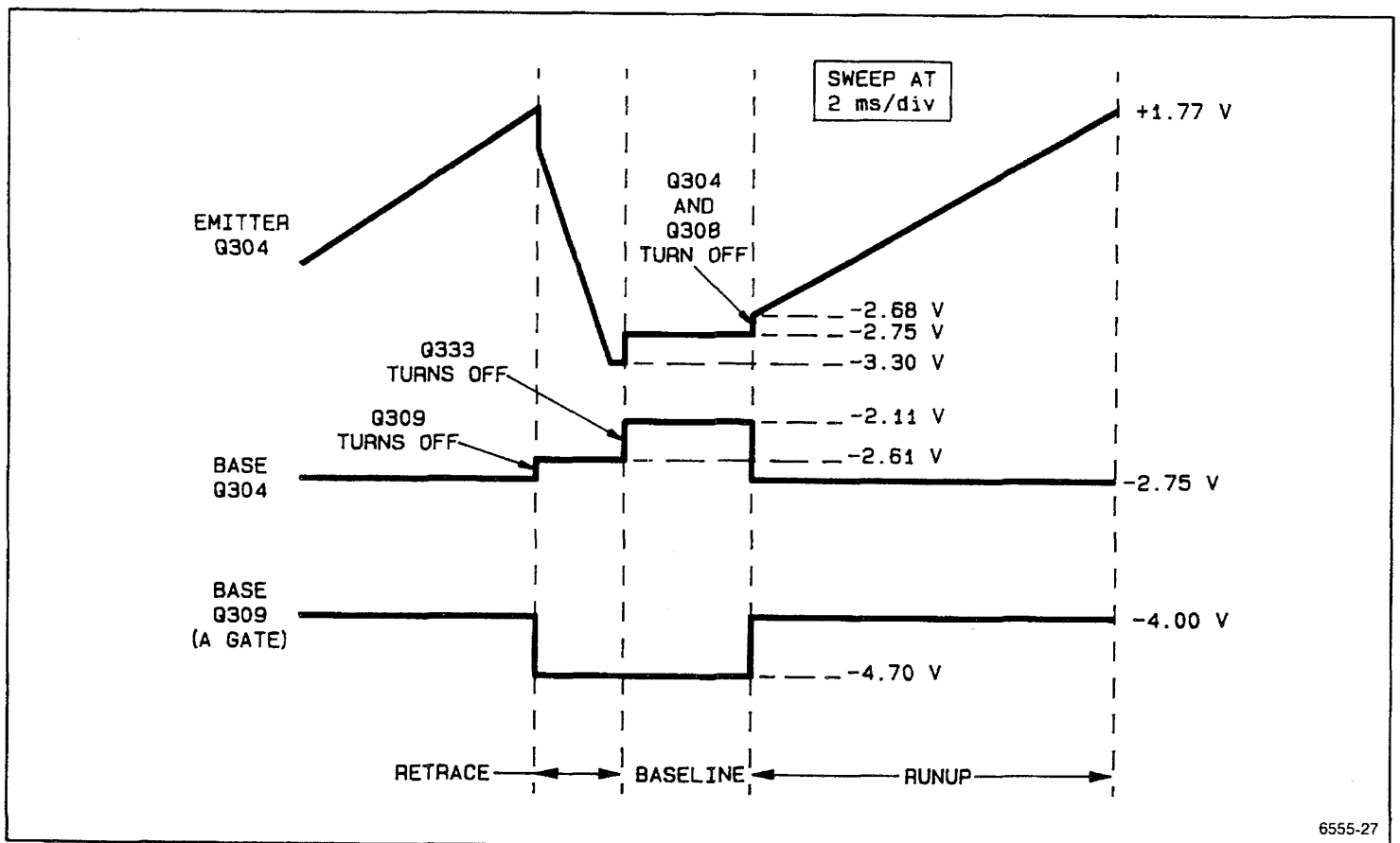

Figure 3-6. A Sweep Start circuit waveforms.

Delay Time Comparators

When the A Sweep ramp runs, its amplitude is compared against two delay levels by the comparators of U313. The differential outputs of the REF delay comparator change states when the A Sweep crosses the first delay level. The differential output signal from the delay comparator is applied to ECL line receiver U315C. That device has a high gain and produces a fast-rise signal at an ECL level. When the DLY END 0 (reference delay completed) is received by the Trigger Logic IC (U602, Diagram 4), a B GATE is produced to start the B Sweep in RUNS AFTER B Trigger mode. That B Sweep displays the applied waveform starting at the first (reference) delay setting.

The differential output of the second delay comparator in U313 changes states when the A Sweep ramp at pin 9 crosses the second (delta) delay level applied to pin 6. At that point, the DLY END 1 signal is produced at the output of U315A (pin 2) and applied to U602. The DLY END 1 signal identifies the end of a gating interval when gated measurements are running.

Delay Time Switching

The DELTA DELAY and REF DELAY voltage level are applied to multiplexer U301C from the DAC circuit. The Measurement Processor established those voltages based on the settings of the CURSOR/TIME POSITION controls made by the user from the front panel. The DLY SEL signal determines whether the REF DELAY or DELTA DELAY will be used to drive DLY END 0.

HORIZONTAL OUTPUT AMPLIFIER (Diagram 6)

Horizontal Preamplifier

Horizontal Preamplifier IC U802 converts single-ended horizontal signals (A sweep, B sweep, horizontal readout, and X-Axis) into differential outputs to drive the crt horizontal deflection plates. The horizontal preamplifier signals are selected by the HD0 and HD1 logic signals from Display Sequencer U600 on Diagram 4. Magnified sweep, beam find, horizontal positioning, and horizontal gain adjustments (X1 and X10) are provided in U802 and associated components.

The function of each pin of U802 is as follows:

RO (Pin 1): RO HORIZ. Input for horizontal component of the readout display.

GA1 (Pin 2): Adjustment of R826 sets the horizontal X1 gain.

A RAMP (Pin 3): Input for the A Sweep signal.

GND (Pin 4): Ground connection for U802.

B RAMP (Pin 5): Input for the B Sweep signal.

MAG (Pin 6): Selects X10 magnified sweep when high or normal sweep when low. Magnified mode is selected when in X-Y horizontal mode. The RO REQ DLY signal turns X10 MAG off when readout is displayed.

X (Pin 7): X-AXIS. This is the X-Axis signal input when in X-Y horizontal mode. The signal source is the CH 1 trigger signal from U421A (Diagram 3). Adjustment of R827 sets the gain of the X-Axis signal.

HD0 (Pin 8): Pin 8 (HD0) and pin 11 (HD1) are logic lines that select the horizontal input signal to output differentially at pins 18 and 19. Table 3-24 gives the selection logic.

Table 3-24
HD0 and HD1 Logic

HD1	HD0	Horiz Signal Selected
0	0	RO HORIZ
0	1	A SWEEP
1	0	B SWEEP
1	1	X-AXIS

V_{EE} (Pin 9): -5 V supply to U802.

GA10 (Pin 10): Adjustment of R825 sets the horizontal X10 gain.

HD1 (Pin 11): See the description for HD0 above.

ROUT (Pin 12): Horizontal Preamplifier differential output signal for the right deflection plate.

LOUT (Pin 13): Horizontal Preamplifier differential output signal for the left deflection plate.

BF (Pin 14): The BEAM FIND signal from U503 (Diagram 4) switch the Beam Find feature on or off.

BEAM FIND on reduces the horizontal deflection to within the graticule area. Vertical deflection is also reduced and the intensity is set to a fixed viewing level to aid in locating off-screen, over-deflected, or under-intensified displays.

POSITION (Pin 15): Input for the horizontal position control signal. Multiplexer section U301B switches to reduce the range of the Horizontal POSITION control to match that of the Vertical POSITION controls when in X-Y horizontal mode. When X-Y display mode is selected, a low \overline{XY} signal on Pin 9 of U301B connects the pin 5 input to the horizontal position input of U802. The signal at pin 5 is a reduced horizontal positioning signal produced by the R353/R358 voltage divider.

V_{CC} (Pin 16): +7 V supply to U802.

Output Amplifiers

The differential output current signal from U802 passes through common-base current amplifiers Q810 and Q809. This current signal is then connected to the bases of Q811 and Q812, through R863 and R873 and on to the bases of Q804-Q803 and Q807. At lower sweep speeds, the signal path is through R863 and R873 to the bases of Q804-Q803 and Q807. These transistors are inverting amplifiers whose collector currents drive the emitters of complementary output amplifiers Q801-Q802 and Q805-Q806, respectively. The circuit of Q804 and Q803 is configured to respond quickly to the negative-going feedback signal, and transistor Q807 is configured to respond quickly to the positive-going feedback signal. Zener diode VR801 maintains the emitter bias of Q803 and Q804 at 11 V.

Magnifier registration and horizontal readout centering is set by MAG REG potentiometer R809. Adjustment of R809 is done to balance the currents into the emitters of Q809 and Q810 to obtain the correct horizontal position of the readout within the graticule display area.

The differential circuitry of both sides of the Horizontal Output Amplifier is similar; operation of only one side of the amplifier is described. The complementary amplifiers Q801 and Q802 produce the negative-going horizontal signal to drive the left deflection plate. Capacitor C802 transfers part of the high-frequency signal to the emitter of Q801 to maintain the gain of the output stage at high sweep speeds. Feedback resistor R806 sets the overall gain of the output amplifier stage, with C807 providing high-frequency compensation. As the frequency of the sweep signal increases, the reactance of C807 decreases and feedback current

increases. To compensate for the increase in drive current required to maintain the gain of the output stage, the fast-path amplifier Q811 increases signal current to the bases of Q804-Q803. High-frequency signal current is shunted around R863 by C860 and R862. As the emitter voltages of Q801 and Q802 decrease to follow the input ramp signal, Q801 is rapidly biased off and Q802 is biased on to absorb all the charge current and produce the negative-going signal to drive the left deflection plate.

Common-Mode Stabilizer

Operation amplifier U801A compares the node voltage at the junction of R820, R821, and R822 to ground. Its output drives the amplifier input common-mode point (at the junction of R811 and R812). The purpose of this dc feedback circuit is to keep the average voltage level on the right and left horizontal deflection plates set to the center of the amplifier's dynamic operating range (about 70 V).

Z-AXIS, CRT, PROBE ADJUST, AND CONTROL MUX (Diagram 7)

Z-Axis and Auto Focus Amplifiers

The Z-Axis Amplifier and Auto Focus Amplifier circuits operate on the same principle and both get their drive signal from the Z-Axis/Focus Driver. However, the differences are enough that both circuits are described.

Z-AXIS AMPLIFIER. Intensity control signal current from the Z-Axis/Focus driver is applied to the Z-Axis amplifier via Q2707. That transistor acts as a current buffer amplifier. The input signal line is clamped at 5.4 V by Q2715 to prevent an overdrive of the Z-Axis circuit. The Z-Axis Amplifier output transistors consist of Q2701 and Q2702 on one side of the complementary-symmetry totem-pole output amplifier and Q2703 and Q2704 on the other side. Two transistors are used on each side to divide the power handling requirements needed to drive the crt control grid. The crt grid capacity is large, and requires a relatively large amount of power to change the intensity level quickly.

In the base circuit of Q2704, CR2705 prevents the base-to-emitter voltage from exceeding 0.6 V. Zener diode VR2701 dc level-shifts the signal voltage level at the emitter of Q2705 for proper biasing of Q2704. The ac signal components are bypassed around VR2701 by C2703. Base biasing for Q2702 and Q2703 is taken from a series-resistance divider formed by R2711, R2712,

R2713, and R2714 between ground and the +130 V supply. Base biasing for Q2701 is provided by R2715 and R2716 in series between ground and the +130 V supply.

A negative-going input signal to the base of Q2705 causes that transistor to decrease conduction, and the voltage at the top of C2705 goes negative following the input signal. Transistor Q2701 is biased on harder by the negative transition, and Q2704 decreases in conduction. At the Z-Axis output signal line (collector of Q2702), the increasing conduction causes the voltage to rise towards the +130 V supply level. A positive-going input signal has the reverse effect on the output signal. The full output-voltage swing of about 60 V is produced by a 3 mA current change of the Z-Axis/Focus Driver signal current.

Gain of the Z-Axis Amplifier stage is set by the feedback through R2708 and R2709 from the collector of Q2702 to the base of Q2705. The amplifier is high-frequency compensated by capacitor C2704 in parallel with the feedback resistors.

BEAM FIND. The Z-Axis portion of the BEAM FIND circuit consists of R2705 and Q2706. When BEAM FIND is active, Q2706 is biased on. This clamps the Z-Axis signal line via R2706 and raises the voltage at the base of Q2705 to a level that produces a bright trace.

Auto Focus Amplifier

The Auto Focus Amplifier (Q2708, Q2709, Q2711, Q2712, and Q2713) uses a sample of the Z-Axis/Focus Driver signal current to drive the auto-focus circuit. The input signal is inverted by Q2708 to drive Q2711 in a complementary fashion to Q2705 in the Z-Axis Amplifier circuit (as the opposite circuit action must happen to produce the correct auto-focus response). The auto-focus output amplifier is similar to the Z-Axis amplifier, but it uses only one complementary transistor on each side (not as much power is needed to drive the focus grid as needed to drive the intensity grid).

Dc Restorers

The Z-Axis and the Auto Focus Dc Restorers are similar in operation. Both circuits are described, but only the added portions of Auto Focus circuitry are included in the discussion of the Auto Focus circuit.

The Dc Restorers set the crt control-grid and focus-grid biases and couple the ac and dc components of the

Z-Axis and the Auto Focus Amplifier outputs to the crt grids. Direct coupling of the Z-Axis and Auto Focus signals to the crt control grid is not employed because of the high potential differences involved. Refer to Figure 3-7 during the following discussion.

Z-AXIS DC RESTORER. Ac drive to the Z-Axis Dc Restorer circuit is obtained from pin 12 of T2204. The drive voltage has a peak-to-peak amplitude of about ± 130 V at a frequency of about 18 kHz and is coupled into the Z-Axis Dc Restorer circuit through R2722 and C2713. The cathode of diode CR2704 is biased by Grid Bias potentiometer R2719 and referenced to ground via R2720. The ac-drive voltage is clamped to the voltage set by the Grid Bias potentiometer wiper whenever the positive peaks forward bias diode CR2704. Capacitor C2710 prevents significant loading of the potentiometer wiper voltage when CR2704 conducts.

The Z-Axis Amplifier output voltage, which varies between +16 V and +66 V, is applied to the Dc Restorer at the anode of CR2703. The ac-drive voltage holds CR2703 reverse biased until the voltage falls below the Z-Axis Amplifier output voltage level. At that point, CR2703 becomes forward biased and clamps the junction of CR2703, CR2704, and C2713 to the Z-Axis output level. Thus, the 18 kHz ac-drive voltage is clamped at two levels to produce a roughly square-wave 18 kHz signal with a positive dc-offset level.

The Dc Restorer is referenced to the -2.7 kV crt cathode voltage through CR2702 and R2723. Initially, both C2712 and C2711 charge up to a level determined by the difference between the Z-Axis output voltage and the crt cathode voltage. Capacitor C2712 charges from the Z-Axis output through R2721, R2723, CR2702, and CR2703, to the crt cathode. Capacitor C2711 charges through R2723 (a series damping resistor), CR2702, and CR2701 to the crt cathode.

During the positive transitions of the ac drive (from the lower clamped level toward the higher clamped level) the charge on C2712 increases due to the rising voltage. The voltage increase across C2712 is equal to the amplitude of the positive transition. The negative transition is coupled through C2712 to reverse bias CR2702 and forward bias CR2701. The increased charge of C2712 is then transferred to C2711 as C2712 discharges toward the Z-Axis output level. Successive cycles of the ac input to the Dc Restorer charge C2711 to a voltage equal to the initial level plus the amplitude of the clamped square-wave input.

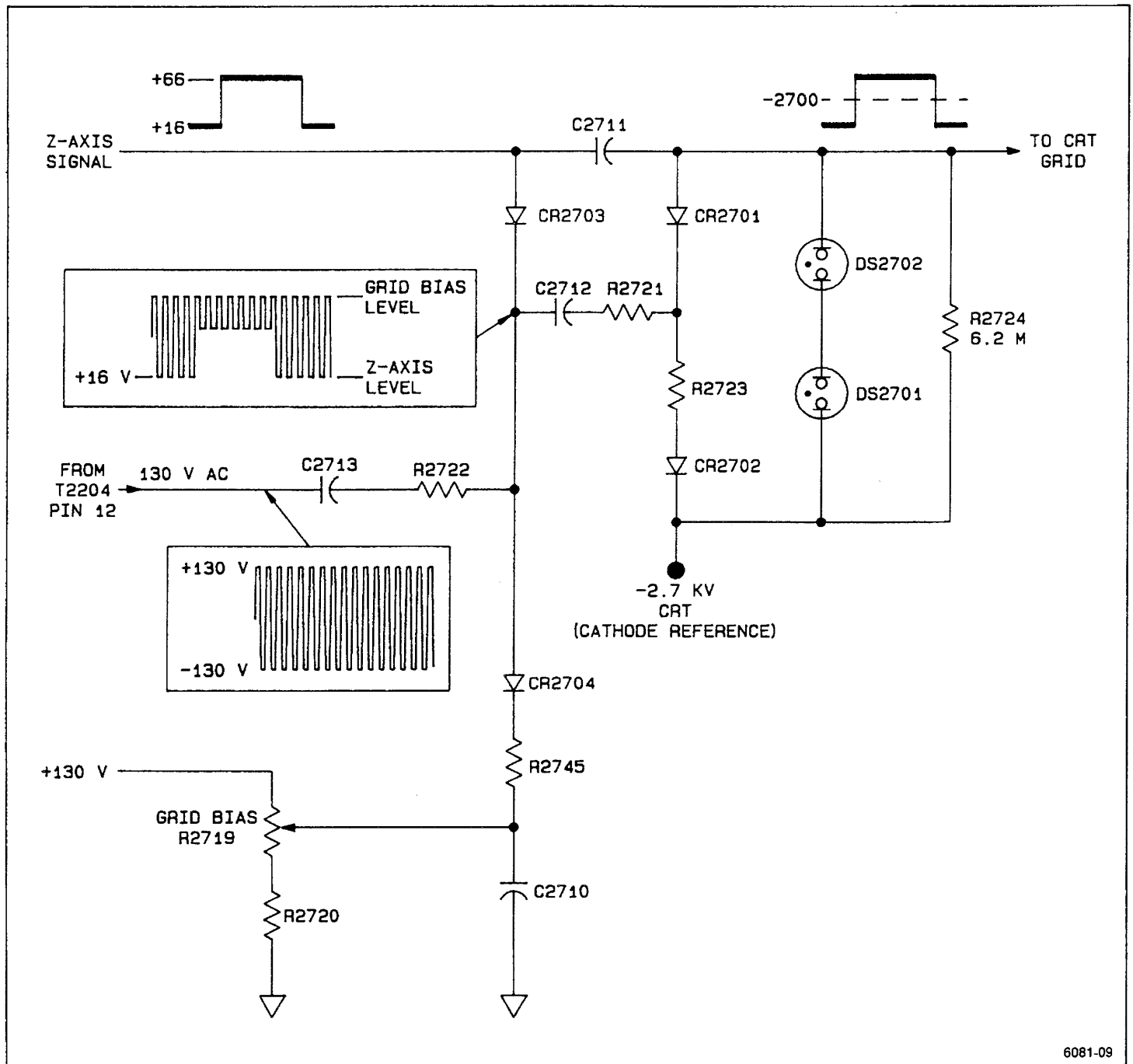

6081-09

Figure 3-7. Simplified diagram of the DC Restorer circuitry.

The charge held by C2711 sets the control-grid bias voltage. If more charge is added to that already present on C2711, the control grid becomes more negative (display dimmer). Conversely, if less charge is added, the control-grid voltage level becomes closer to the cathode-voltage level, and the display becomes brighter. During periods that C2712 is charging, the crt control-grid voltage is held constant by the long time-constant discharge path of C2711 through R2724.

Fast-rise and fast-fall transitions of the Z-Axis output signal are coupled to the crt control grid through C2711 to start the crt writing-beam current toward the new intensity level. The Dc Restorer output level then follows the Z-Axis output-voltage level to set the new bias voltage for the crt control grid.

Neon lamps DS2702 and DS2701 protect the crt from excessive grid-to-cathode voltage if the potential on

either the control grid or the cathode is lost for any reason.

AUTO FOCUS DC RESTORER. The action of the Auto Focus circuit has to be in reverse of the action of the Z-Axis circuit. The differential transistor pair of Q2708 and Q2709 provides drive to the Auto Focus Amplifier that is inverted in polarity to the Z-Axis signal. As the intensity increases (more beam current), the focus grid bias must become more positive to maintain the focus of the beam. Also, since the focus grid operates at a less negative level than the control grid, the Auto Focus DC Restorer is referenced to the -2.7 kV supply via a voltage divider chain.

The FOCUS potentiometer (R2758) voltage is taken across the middle resistor of the divider string to provide an adjustable focus voltage that sets the nominal focus level. Capacitor C2758 filters the reference supply voltage for the focus circuit.

Volts Cal Signal Source

This circuit provides the precision voltages required for setting the voltage measurement constants during the SELF CAL routine. Ground is connected to the vertical input when GND Input Coupling is selected.

Five voltages are selected from a precision voltage divider, R921, and multiplexed through U931 to the vertical inputs at the appropriate time during the SELF CAL routine. Selection is controlled by three binary coded lines (VOLT CAL 0, 1, 2) from U303. Those control bits and the selected output voltage may be checked one at a time by running the VOLT REF exerciser from the Service Menu.

Control Multiplexer

Multiplexer U506, controlled by Data Latch U2313 on Diagram 11, selects the A INTEN, B INTEN, and READOUT control levels and probe code voltages to be sent on the MAIN BD MUX signal line to multiplexer U2309 on Diagram 11. The bit coding is shown in Table 3-25. The selected output from U2309 is applied to the A-to-D Comparator (U2306, Diagram 11) where its voltage level is determined by the Measurement Processor.

Scale Illumination

Front panel SCALE ILLUM control R905 varies the base current of Q905, Q907, and Q908 to set the intensity levels of the scale illumination bulbs (DS901, DS902, DS903).

Table 3-25
Front-Panel Multiplexer
Channel Select Bits

CONTROL LINE			Analog Signal Selected
POT7	POT6	POT5	
0	0	0	A INTEN
0	0	1	RO INTEN
0	1	0	CH 1 PROBE
0	1	1	CH 2 PROBE
1	0	0	CH 3 PROBE
1	0	1	CH 4 PROBE
1	1	0	B INTEN
1	1	1	ANALOG GND

NOTE

Bulb life is extended by keeping SCALE ILLUM control set low or off except when full intensity is required.

Probe Adjust Circuit

The Probe Adjust circuit generates a 0.5 V square wave signal at about 1 kHz. Operational amplifier U930A has a gain of about 4. The $+2.5$ V reference on its noninverting input produces a little over 10 V at the output pin. That voltage is divided by the voltage divider formed by R936, CR936, and R937 for a peak amplitude of the signal of 0.5 V during the time CR936 is forward biased. When CR936 is reverse biased by the output of U930B, the Probe Adjust output voltage is pulled down to 0 V through R937 to ground.

Operational amplifier U930B is a free-running oscillator circuit with a period of about 1 ms. The oscillator frequency is determined mainly by the charging time constant of C935 and R935. The voltage divider formed by R938, R934, and R939 divides the $+15$ V supply to provide a positive voltage on pin 5 of the oscillator to get the circuit into oscillation. (When the circuit is oscillating, the feedback signal switches the pin 5 voltage between about $+8$ V to 0 V.) The gain of the amplifier is high enough to drive pin 7 to the positive supply voltage level at about 14 V, and the signal voltage level on pin 5 rises to a little over 8 V from the feedback current supplied by

R933. The CLK 1K signal taken from the junction of R934 and R939 is supplied to U600 and is used to skew the chop-clock frequency. The skew prevents the oscilloscope from triggering on the chop frequency when displaying multiple traces in CHOP Mode.

At that level CR935 is reverse biased, and CR936 is forward biased (by the output of U930A) to pass the Probe Adjust high level output signal current. Charging current through feedback resistor R935 charges C935 up from 0 V toward the output voltage level. As soon as the charge on C935 (and the voltage on pin 6 of U930B) reaches the voltage level on pin 5, the output level at pin 7 drops to about -5 V, and C935 must then begin discharging to the new voltage level. At that point CR935 is forward biased and that reverse biases CR936 so that the Probe Adjust output voltage drops to 0 V. Resistor R940, in series with CR935, limits current flow to protect U930 and CR935 in the event of a static discharge to the PROBE ADJUST output connector.

Crt

The Trace Rotation adjustment, R911, varies the current through the Trace Rotation coil. The Trace Rotation coil is located between the crt face and the vertical and horizontal deflection plates, and it affects both the vertical and horizontal alignment of the trace.

The Geometry adjustment, R2784, varies the voltage level on the horizontal deflection-plate shields to control the overall geometry of the display (minimizes bowing of the display).

The Astigmatism adjustment, R2788, varies the voltage level on the astigmatism grid to obtain the best-focused display over the whole face of the crt.

MEASUREMENT PROCESSOR (Diagram 8)

The Measurement Processor circuitry includes the Processor (U2501), the System RAM (U2521), the System ROM (U2519), communication bus latches and transceivers, the Address Decoding circuitry, and the Power-On Reset IC (U2502).

Power-On Reset

The +5 V supply is monitored by U2502 to generate the reset signals throughout the instrument. These reset signals initialize the states of the logic devices and ensure

that memory writes to any of the RAM spaces cannot occur until the +5 V supply is up to its correct operating level. The RESET signal output at pin 6 is initially high during power up (as soon as the voltage has reached the operating level of the RESET IC, U2502). That high signal is inverted by U2506C to produce the $\overline{\text{SYS RESET}}$ signal. The $\overline{\text{SYS RESET}}$ signal holds Processor U2501 in its reset state.

The $\overline{\text{SYS RESET}}$ signal also resets and initializes the Readout Processor (U2400, Diagram 9) and DAC Processor (U2601, Diagram 13). At pin 5 of U2502, a $\overline{\text{RES}}$ signal is generated. That signal biases Q2507 off to prevent System RAM U2521 from being selected by any random states that might occur on the address lines during reset as the voltage is rising.

About 5 ms after the +5 V supply reaches the operating level required for the Processor, the RESET condition is removed, allowing the Processor to operate. At power off (and for a momentary drop in the +5 V supply), when the +5 V supply falls below the safe operating level of the logic devices, the RESET condition occurs to prevent random operation.

Measurement Processor

FUNCTION. Measurement Processor U2501 is a multitasking device. Its major functions are the following:

1. Continually refreshes the front panel indicator LEDs. One column of the six-column LED matrix is refreshed every 2.048 ms.
2. Continually scans the front panel switch settings, sensing rotation of rotary switches and closures of momentary-contact switches. One column of the six-column switch matrix (the same column number of LEDs being refreshed) is read every 2.048 ms.
3. Communicates with the Readout Processor and Readout RAM to set attributes for each readout field, put text into each field, and turn the readout fields on or off.
4. Scans the front panel pots and sets control voltage levels. The Measurement Processor selects a pot to be read and connects it to A-to-D Comparator U2306 in the d-to-a circuitry. The Measurement Processor does a successive-approximation a-to-d conversion on each pot, using the DAC (U2302) to output the search values to the

Comparator. Pot values are scanned, processed, and converted to analog control values by the DAC. The analog levels from the DAC are output to the controlled devices via sample-and-hold circuits (U2304, U2305 on Diagram 11 and U2606, U2607, U2608 on Diagram 13).

5. Sets up the hardware state of the instrument, including shift registers 0 and 1, BEAM FIND, and the operating states of U600 (SLIC) and U602 (FLIC). *This setup takes place as needed for every change of a front panel momentary-contact or rotary-contact switch.*
6. Keeps track of trigger status and controls the trigger levels when in AUTO LEVEL mode. It uses FLIC (U602) to find the A Trigger status (writing to FLIC to reset the A Trigger latch, and reading from it to get the status). It uses SLIC (U600) to find the B Trigger status (writing to SLIC to reset the B Gate latch, and reading from it to get the status). To reacquire the trigger level (positive and negative peaks of the trigger source waveform) it uses the Trigger ICs (U421 and U431), and the Trigger Comparators in FLIC (it writes to FLIC to reset the Trigger comparator latches, and reads from FLIC to get the status of the latches). To switch between free-running and triggered mode in AUTO LEVEL and AUTO trigger modes, it writes to the control register in FLIC; it switches to triggered mode when trigger frequency is sufficiently high and to free-run mode when too low.
7. Tracks the trigger level and ground with cursors. The cursors are displayed by directing the Readout system to display cursor characters, and using the DAC system to set the REF CURSOR and DELTA CURSOR level to match the trigger or ground point on the waveform.
8. Does automated measurements. Some measurements are knob-driven. They are:
 - ← SEC →
 - ← 1/SEC →
 - ← PHASE →
 - ← VOLTS →
 - ↗ VOLTS →

When these measurements are running, a new digital value is displayed, and the cursor or delay-zone position is changed only when the user

changes the setting of one of the continuous-rotation CURSOR/TIME POSITION controls. Other measurements are waveform-driven. They are:

DC
 + PEAK
 - PEAK
 PK-PK
 GATED + PEAK
 GATED - PEAK
 GATED PK-PK

When these measurements are running, a new digital value is displayed and the cursor position is changed each time a measurement cycle occurs. These measurements use the B trigger system; and, for DC, the low-pass circuit formed by U1101B and associated filter components (Diagram 3).

9. Controls Counter/Timer (C/T) operation—tells the C/T when to start and stop counting and calculates the results. The Measurement Processor communicates with the C/T via a microprocessor interface contained in Slow Counter Logic (SCL) U1902 (diagram 12). This interface provides the capability for the Processor to write an 8-bit control word to SCL, read out the three count chains, read the overflow status bits, clear the overflow status bits, and interface to the fast-logic half of the counter subsystem (FCL U1905).

The Processor sets a bit (called ENABLE) in FCL to enable the C/T to start counting trigger events (period and width measurements) or delay intervals (delta-time measurements). When the C/T starts counting, the $\overline{\text{BUSY}}$ line (from the C/T to the Processor) goes low to indicate that the C/T has started measuring. After measurement time is up, the Processor sets the ENABLE bit low, the C/T stops counting, and the $\overline{\text{BUSY}}$ line goes high. Then the Processor calculates the measurement value. When a gated frequency or period measurement is performed, the procedure is about the same, except that the C GATE signal from U602 (diagram 4) arms the C/T; the ENABLE bit is still used to tell the C/T when to start arming itself with C GATE. The $\overline{\text{BUSY}}$ signal toggles low and high to tell the Processor when the measurements start and stop.

10. Controls the AUTO SETUP function by setting up the vertical, horizontal, triggering, and crt controls to obtain a usable display based on the input signal characteristics.

11. Controls the STORE/RECALL system store and recall functions.
12. Calibrates the measurement system. The vertical and horizontal gains of the instrument are set by manual potentiometer adjustments; therefore, the Processor does not control the match between the waveform display and the graticule. However, it does adjust the measurement results to compensate for any error in the vertical or horizontal gain.

In the Time Base calibration routine, the Measurement Processor uses the TB Cal signal, the Trigger circuitry, the A Sweep system, and U602 (FLIC) to find the match between the delay levels (REF DELAY and DELTA DELAY) and edges of the calibration signal. In the Vertical System calibration, the Processor uses the Volts Cal Signal Source (U931, Diagram 7), the Readout System, the Vertical Preamplifiers, the Delay Line Driver, and the Vertical Comparator (U702, Diagram 2) to find the match between Readout REF CURSOR and DELTA CURSOR levels and vertical outputs generated by the preamplifiers. It uses the Volts Cal Signal Source, the Vertical Preamplifiers, and the Trigger circuitry to find the match between trigger levels and trigger signals picked off from the Vertical Preamplifiers.

MEASUREMENT PROCESSOR SIGNALS. Table 3-26 is a listing of signal name and function of the Measurement Processor signals.

Data Buffers

BUS 0 BIDIRECTIONAL BUFFER. Buffer U2515 communicates the serial bit data to and from the Measurement Processor. Seven data lines of the eight available are used in this application. The remaining one is connected to the +5 V supply to prevent random states and noise from affecting the other data lines in the device. The buffer is enabled via U2503B when both pins 38 (MCS0) and 39 (\overline{DEN}) of the Processor are low. The direction of transfer is controlled by the DT/\overline{R} output of the processor.

BUS 1 BIDIRECTIONAL DATA BUFFER. Data communication to and from the Measurement Processor is via Buffer U2514. Direction of the data transfer is controlled by the DT/\overline{R} (Data Transmit/Received) output from the Measurement Processor. Data enabling occurs when pin 39 (\overline{DEN}) goes low while pin 38 (MCS0) is high.

BUS ARBITRATION GATES. The Bus Arbitration logic (U2503A and B, and U2506D) controls which Bus Buffer is enabled for communication with the Measurement Processor. This control logic is necessary since both buffers cannot be active at the same time. Bus 1 (U2514) is the eight-bit data communication bus, and Bus 0 (U2515) uses seven bits to communicate single-bit data to the Measurement Processor. On the Bus 0 AD0 signal line, the Measurement Processor sends the serial MB DATA to each of the operating mode Shift Registers and to SLIC (U600) and FLIC (U602). Additional arbitration is provided by U2503C to produce a $\overline{SLIC RD}$ strobe when the Measurement Processor wants to read the status of the Display Controller.

Address Latches

MULTIPLEXED AD BUS ADDRESS LATCH. Since the AD0 through AD7 bits are multiplexed between address and data information, the addressing information needs to be latched to hold it for stable addressing (demultiplexed). The ALE (Address Latch Enable) signal from the Measurement Processor (pin 61) goes high when the address bits are stable, and the bits are latched into U2513. The device is permanently enabled by the grounded enable pin.

NONMULTIPLEXED ADDRESS BUS ADDRESS LATCH (U2512). Some of the nonmultiplexed address bits are also latched to maintain them between ALE strobes. The latching also prevents address line problems on the Main board from locking up the Measurement Processor. From U2512, latched addresses ADDR0-ADDR3 (A12-A15) are routed to the Display Controller (U600) for addressing the internal registers in that device. Those address lines are also applied to U501 (Diagram 4) for additional decoding to load the Analog Control Shift Registers with the serial data supplied from the MB DATA signal line. Two address lines (A16-A17) are latched in U2512 for use by the System ROM U2519.

Measurement Processor ROM

The operating code for the Measurement Processor is stored in the System ROM (U2519). Immediately after the Power On Reset ends, the Measurement Processor fetches the first command from the reset vector and begins running the program.

Table 3-26
Measurement Processor Signals

Signal Name	Signal Function
$\overline{\text{SYS RESET}}$	Master reset for the Processor board.
CLK 8M	8 MHz clock for the Readout and DAC Processors.
AD0-AD7	Multiplexed address/data lines for the Measurement Processor.
A8-A15	Address lines for the Measurement Processor.
A16-A17	Multiplexed address/status lines.
D0-D7	Data lines for Bus 1 (to memory and readout).
ADDR3-ADDR0	Latched addresses to Main board.
$\overline{\text{RO INTR}}$	Indicates the Readout System is busy when asserted.
$\overline{\text{DAC INTR}}$	Indicates the DAC Subsystem is busy when asserted.
MB RETURN	Return data from the Main board Shift Register 2.
SW BD DATA	Data from the switch board.
AD COMP	Output of the A-to-D Converter Comparator, U2306.
MB DATA	Bidirectional data line to/from the Main board.
TB CAL	Time-base calibration signal to trigger circuit.
$\overline{\text{SCL SEL}}$	Slow Counter Logic chip select (Counter/Timer).
$\overline{\text{RD}}$ and $\overline{\text{WR}}$	Control direction of communication with the devices on the data bus.

Measurement Processor RAM

The Measurement Processor RAM (U2521) provides storage space for intermediate-step calculation results, the front panel settings, store/recall system setups, and the system calibration constants. The Processor RAM is battery backed up so that data stored during operation remains intact during periods of power off. When the instrument is turned on again, the stored front panel settings return the oscilloscope to the same operating state that was present at power off. The stored calibration constants preserve the accuracy of the measurement system (assuming the instrument is warmed up and was warmed up when the SELF CAL routine was last done). If the backup battery is dead, or if the stored calibration constants are lost for some other reason, the instrument will do a SELF CAL at power on. This restores accuracy to the instrument (unless the problem is a RAM fault, in

which case the instrument cannot SELF CAL), but the battery circuitry should be checked and the battery replaced if necessary. Also, the SELF CAL routine should be run again after the instrument is warmed up to generate accurate calibration constants at the operating temperature. If the power-off front panel settings are lost for any reason, the power-on conditions that are set up are only restored in valid states (but not any predefined setup).

Address Decoders

The Address Decoders (U2517 and U2518) allow the Measurement Processor to enable any device on the busses for communication. Enabling signals $\overline{\text{BUS0 SEL}}$ and $\overline{\text{DAC SEL}}$ from the processor select the Address Decoder (either U2517 or U2518) that is actively decoding when the $\overline{\text{WR}}$ signal is low.

Backup Battery

To keep the data stored in the Measurement Processor RAM (U2521) during power off, a back-up battery system (BT2501, CR2502, and R2506) is used. The battery supplies the energy to maintain the memory states of the static RAM. The lithium battery is not rechargeable and has an operating life of over five years. When the instrument is on, CR2502 becomes reverse biased to prevent any reverse current; when off, CR2501 is reverse biased to isolate the back-up battery from the +5 V supply. If the battery requires replacement, observe the proper safety precautions in the handling and disposition of the replaced battery (see the WARNING under "Battery" in the Specification).

READOUT SYSTEM (Diagram 9)

Readout Processor

The Readout Processor (U2400) is an eight-bit micro-computer, containing its own internal ROM and RAM. The Readout Processor controls the display of text and cursors on the crt. It refreshes each character in the display every 16 ms. When the refresh rate becomes too high, refresh stops until the rate is low enough again. When the refresh rate becomes too low, refresh is done by taking control of the crt beam for a character at a time (Fast mode), until the refresh catches up. When the refresh rate is just right, refresh is done a dot at a time (Slow mode).

Each refreshed dot or character is refreshed with the appropriate display position attributes. The attributes define the characters or dots as:

Stationary text that stays put at a fixed point on screen (examples are scale factor and menu displays).

Cursor-level offset text whose position is determined by the REF CURSOR or DELTA CURSOR control levels only (examples are the time-measurement cursors).

Cursor-level and position-level offset text whose display position is determined by both the cursor levels and the vertical position controls (an example is the TRACK TRIG LEVEL cursor).

The Readout Processor also communicates with the Measurement Processor system to obtain its RAM programming (for determining the display types) and report its status.

Measurement/Readout Processor Communication Protocol

A data byte is transmitted between the Measurement Processor and Readout Processor as follows:

1. The Measurement Processor waits until $\overline{RO\ INTR}$ is unasserted (the Readout Processor is ready to receive).
2. The Measurement Processor writes a byte to tri-state Write Latch U2401 by strobing $RO\ BUF\ WR$; this asserts $\overline{RO\ INTR}$ (from Interrupt Latch U2417C and D) and causes an interrupt to the Readout Processor.
3. The Readout Processor, when interrupted, reads the Write Latch (U2401); it then unasserts $\overline{RO\ INTR}$ by clocking the Interrupt Latch to reset it. (This is the same clock used when the Readout Processor writes to tri-state Read Latch U2402.)

Communication from the Readout Processor to the Measurement Processor is done for diagnostics only and can be started only by the Measurement Processor. The Measurement Processor may check the communication link by comparing bytes sent to bytes received, query the Character Code RAM contents, and check the Character ROM identification header. The replies are all sent between the Readout Processor and Measurement Processor a byte at a time as follows.

1. The Readout Processor waits until $\overline{RO\ INTR}$ is asserted (the Measurement Processor is ready to receive).
2. The Readout Processor writes a byte to tri-state latch U2402; the clock that does the write also unasserts $\overline{RO\ INTR}$.
3. The Measurement Processor waits until $\overline{RO\ INTR}$ is unasserted, then reads tri-state latch U2402. It then strobes $RO\ BUF\ WR$ to assert $\overline{RO\ INTR}$ (if another byte is coming from the Measurement Processor).

Display Refreshing

READOUT FIELD. A Readout field is refreshed in this way:

1. The display field is selected by latching the top address bits for the field into U2411 (FLD2–FLD0).
2. The mixing attributes for the field are latched into U2411 (MIX3–MIX0).
3. The position-tracking attributes for the field are latched into U2403 (RO CH 4 POS EN through RO CH 1 POS EN and RO TR SEP EN).
4. The starting address for the field (set by communication with the Measurement Processor) is latched into counters U2404 and U2405 (CH7–CH0).
5. One character at a time, all the characters in the field are refreshed until the top address for the field (set by communication with the Measurement Processor) has been refreshed.

READOUT CHARACTER. A Readout character is refreshed in this way:

1. $\overline{\text{RO RUN}}$ is asserted. This tells the Dot Refresher PAL (U2410) to begin the character refresh and releases the reset on the Dot Counter (U2407) and the Dot Refresher divider (U2409B).
2. For each dot in the character, the next dot is refreshed.
3. When the final dot is refreshed, $\overline{\text{EOCH}}$ (end-of-character at U2408 pin 17) becomes asserted, and $\overline{\text{Q EOCH}}$ (the latched version) becomes asserted. The Readout Processor unasserts $\overline{\text{RO RUN}}$, and increments the character address counter lines CH7–CH0.

READOUT DOT. A Readout dot is refreshed in this way:

1. $\overline{\text{RO REQ}}$ is asserted (this causes RO HORIZ and RO VERT to control the crt horizontal and vertical) briefly to show the dot.
2. $\overline{\text{RO BLANK}}$ is unasserted then asserted (this unblanks then blanks the crt beam).
3. $\overline{\text{DOT CLK}}$ is asserted and unasserted (this increments the dot counter lines DOT4–DOT0).

FAST REFRESH. Fast refresh occurs when the Processor asserts $\overline{\text{FAST}}$ (whenever the refresh rate is too low) or when $\overline{\text{A GATE}}$ is unasserted (the sweep is in holdoff). In this mode, $\overline{\text{RO REQ}}$ is asserted at the start of a character, and unasserted at the end. Whenever $\overline{\text{RO REQ}}$ is asserted, the Readout system controls the crt beam intensity and the vertical and horizontal position of the beam. Dots are refreshed every 1.6 μs during fast refresh.

SLOW REFRESH. Slow refresh occurs when the Processor unasserts $\overline{\text{FAST}}$ (when the refresh rate is not falling behind in refreshing the readout) and $\overline{\text{A GATE}}$ is asserted. In this mode, $\overline{\text{RO REQ}}$ is asserted before each dot in a character, and unasserted after each dot.

Data flow for the dots in a character is roughly this:

1. FLD2–FLD0 give the current field being refreshed.
2. CH7–CH0 give the position of the character within that field. CH7–CH5 gives the row within the Readout (row 0 at the bottom, and 7 at the top), and CH4–CH0 gives the column (column 0 at the left, column 1f hex at the right).
3. Given the field and character position, the RAM (U2406) outputs the character code (the code for the character that is to be displayed at that position) on R7–R0.
4. DOT4–DOT0 gives the dot that is being refreshed within the character.
5. Given the character code and dot number, ROM U2408 outputs the position of the dot within the character. There are up to 31 dots in a character, in an array of 128 possible dot positions (16 vertical by 8 horizontal). DD6–DD3 gives the vertical position of the dot, and DD2–DD0 gives the horizontal position.
6. Given the row and column containing the character, and the vertical and horizontal position of the dot, U2412 generates the vertical analog current for the dot, and U2413 the horizontal analog current.
7. U2414 sets up the mixing for the vertical output signal (see Readout Position Mixer).
8. U2415 sets up the mixing for the horizontal output signal.

Interrupt Request Latch

When the Measurement Processor wants to write new display data to the Readout Processor or Character Codes RAM (U2406), it latches the new data into the Readout Write Latch (U2401) from the D0–D7 bus lines by issuing the $\overline{RO\ BUF\ WR}$ (readout buffer write) strobe to the Interrupt Request Latch (U2417). The output of U2417D (pin 11) is latched low and the Readout Processor is interrupted from its display processes ($\overline{RO\ INTR}$ goes low). The Readout Processor enables the Readout Write Latch and reads in the new data. When the character is received, the Readout Processor transfers the byte to the Character Code RAM and resets the Interrupt Request Latch (U2417C and D) to let $\overline{RO\ INTR}$ go high again.

Communication Latches

Communication from the Measurement Processor and the Readout Processor is done via the Readout Write Latch (U2401). The Readout Read Latch (U2402) is used only for diagnostics communication.

Character Position Address Counter

The starting address of a readout field to be displayed is loaded into the Character Position Address Counter (U2404 and U2405). The counter then sequences through the addresses of the characters loaded in Character Code RAM U2406. The vertical and horizontal position of the character being displayed is also defined by the output of the counter and is supplied to the Vertical and Horizontal DACS on the CH0–CH7 bus lines.

Character Codes RAM

The ASCII codes needed to display a field of readout are loaded into the Character Codes RAM (U2406) from the Measurement Processor via the Readout Writer Buffer (U2401) on the R0–R7 bus lines. When the field is displayed, the RAM is addressed in sequence by the Character Position Address Counter to output those codes for a display refresh. The field of codes accessed by the FLD0–FLD2 address lines defines either text (menus, measurement readouts, and error messages), vertical cursors, or horizontal cursors. Each field has space for up to 255 characters, and each field is superimposed over the others on the crt. A voltage (horizontal) cursor is generated by holding the vertical at the REF CURSOR voltage and displaying a whole line of dashes in the horizontal. A time (vertical) cursor is generated by

holding the horizontal at the REF CURSOR voltage and routing the whole line of dashes (as above) from the Horizontal DAC to the vertical signal mixer multiplexer. Hexadecimal addresses for a field are shown in Figure 3–8.

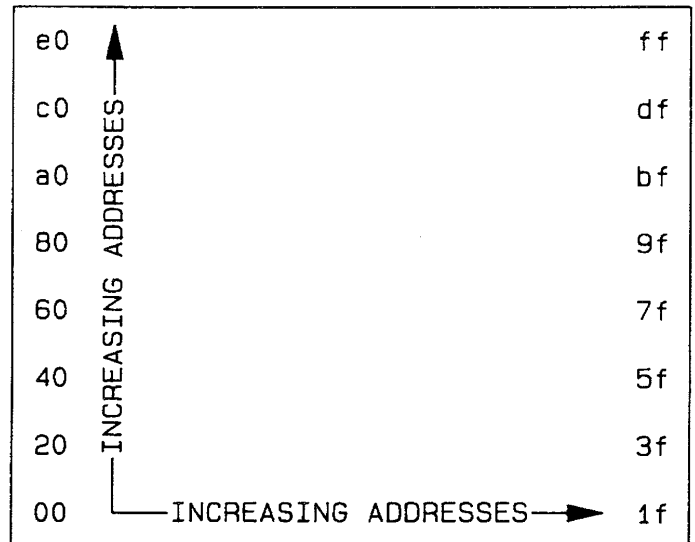

6081-10

Figure 3–8. Display addresses.

Character Dot Counter

The Character Dot Counter (U2407A and B) is reset before the start of each character display. When $\overline{RO\ RUN}$ goes low (the start of a refresh cycle), the reset is released and the clock signal from the Dot Refresher (U2410) clocks the output of the counter through the number of counts needed to address all the dots in a character stored in the Character Dot Position ROM (U2408).

Character Dot Position ROM

The dot sequence and dot position to display each character is stored in the Character Dot Position ROM (U2408). Character addressing for the display is provided by the Character Codes RAM (U2406) on the R0–R6 bus lines. Addressing of the individual dots within a character is provided from the Character Dot Counter (U2407A and U2407B) on the DOT0–DOT4 signal lines. The pixel information output by the Character Dot Position ROM defines the vertical and horizontal position of the dot to be displayed. At the end of a character display, the \overline{EOCH} signal is generated from U2408 pin 17 to the Dot Refresher (U2410) to let that device know that the character is finished and the next character can be started.

Dot Refresher

Dot Refresher U2410 is a programmable-AND, fixed-OR logic (PAL) device. It monitors $\overline{RO\ RUN}$ for its low states to determine when a refresh cycle starts. It then asserts $\overline{RO\ REQ}$ to take control of the display for refreshing the displayed character dots. $\overline{RO\ BLANK}$ goes high then low again for each displayed dot. The clock signal then goes low and high again to clock the Character Dot Counter (U2407A and U2407B) to the address of the next dot in the character being refreshed. In Fast mode (when there is low demand for display time or the refresh rate is getting too slow), each character is completely refreshed. In Slow mode, the dots are refreshed at the rate of only one dot per each readout request.

When all the dots in a character have been refreshed, the \overline{EOCH} (end-of-character) signal from Character Dot Position ROM U2408 (pin 17) tells U2410 that there are no more pixels to be refreshed in that character. $\overline{RO\ REQ}$ is then unasserted to release control of the display system and $\overline{Q\ EPOCH}$ (U2410, pin 18) is sent to the Readout Processor to tell it that the Dot Refresher is finished with the character.

The Dot Refresher also asserts the $\overline{POS\ EN}$ signal low (pin 19) when readout associated with any of the traces is being displayed. That signal enables the Readout Position Enable Latch (U2403).

Divider/Counter

The 8 MHz System Clock is divided down to 4 MHz by Divider/Counter U2409A for clocking the Readout Processor and to 2 MHz to clock the Dot Refresher (after inversion by U2417B). The 2 MHz signal also clocks U2409B, a second divider that produces the signals that cycle the Dot Refresher through its internal states.

Readout Position Enable Latch

When the readouts must follow the Channel Vertical POSITION controls or the TRACE SEP control, the vertical position information must be added to the readout position. This job is done in the Vertical Position Switching circuitry (Diagram 2). The time of enabling and the readout position that is enabled is determined by the Readout Processor. The correct enabling data for the next field of characters to be displayed is latched into U2403 from the R0-R7 (bits 0-4 only) bus by the $\overline{POS\ STB}$ signal (U2403, pin 11). See Table 3-27. When a field is being refreshed, the outputs of U2403 are enabled by the $\overline{POS\ EN}$ signal from the Dot Refresher, U2410 pin 19.

Table 3-27
Position Enable Bit Assignment

b4	b3	b2	b1	b0	Value
x	x	x	x	0	Disable CH 1 position current
x	x	x	x	1	Enable CH 1 position current
x	x	x	0	x	Disable CH 2 position current
x	x	x	1	x	Enable CH 2 position current
x	x	0	x	x	Disable CH 3 position current
x	x	1	x	x	Enable CH 3 position current
x	0	x	x	x	Disable CH 4 position current
x	1	x	x	x	Enable CH 4 position current
0	x	x	x	x	Disable Trace Sep current
1	x	x	x	x	Enable Trace Sep current

Readout DACs

Vertical Character and Dot position data bytes are converted to analog current for eventual application to the Vertical Delay Line by Vertical Readout DAC U2412. The vertical signal current is applied to signal mixer multiplexer U2414. When fixed position text is displayed, the output mixer selects a fixed position value to mix with the vertical output signal to define the readout position on the display. When time cursors are displayed, the horizontal output signal defines (vertically) where a character (dot) is displayed on the crt. Vertical Readouts that follow the Channel Vertical POSITION controls (tracking cursors and associated text) have their position information summed with the Vertical Position Switching circuitry (Diagram 2) just before the Delay Line Driver.

Horizontal Character and Dot position data bytes are converted to analog current for application to the Horizontal Preamp (U802, Diagram 6) by Horizontal Readout DAC U2413. The horizontal signal current is applied to both signal mixer multiplexers (U2414 and U2415). When fixed position text is displayed, the output mixer selects a fixed position value to mix with the horizontal output signal to define the readout position on the display. When time cursors are displayed, the cursor

position signal defines (horizontally) where a dot is displayed on the crt. None of the readout (text or cursors) is positionable using the Horizontal POSITION control.

Field and Mixer Control Latch

Selection signals for switching the Readout Position Mixer multiplexers (U2414 and U2415) are latched into Field and Mixer Control Latch U2411 by the MIX STB output from the Readout Processor (U2400 pin 25). Three field selection bits used in addressing the Character Code RAM are also loaded from the data byte output from U2400 on the R0-R7 data bus. The MIX3-MIX0 bits select the combination of fixed, positionable, and character (dots) signals that are mixed to produce the required readout positions on the crt.

The Field signals (CH8, CH9, and CH10) access the type of characters that are displayed (menus and readout labels, vertical cursors, or horizontal cursors). Each of the three fields contains space for 255 characters. Characters from each field are superimposable over the other field's characters in the display. The attributes implicitly affect the field specified by b0, b1, and b2 (b2

is always handled as if zero, even if not communicated as zero).

Readout Position Mixers

The Readout Position Mixer (U2414, U2415) selects either fixed or cursor-position voltages to mix with the character signals to position them in the display. Selection is done with the MIX0-MIX3 signal levels set by the Measurement Processor for the particular field of characters being displayed (see Table 3-28).

The 2247A Readout Output Mixer allows three modes of display to present the text and vertical or horizontal cursors.

TEXT OUTPUT MODE. The vertical output displays vertical text information, locked to crt vertical screen position. The horizontal output displays horizontal text information, locked to crt horizontal screen position.

HORIZONTAL CURSOR MODE. The vertical output displays vertical text information, whose position is controlled by an analog cursor level control. The horizontal output displays horizontal text information, locked to crt horizontal screen position.

Table 3-28

Field and Mixer Attribute Bit Assignment

MIX3	MIX2	MIX1	MIX0	NC	CH10	CH9	CH8	Value
x	x	x	x	x	b2	b1	b0	Field number (0,1, or 2)
x	x	0	0	x	x	x	x	Route Horiz DAC to Horiz Ampl
x	x	0	1	x	x	x	x	Route Cursor0 to Horiz Amplifier
x	x	1	0	x	x	x	x	Route Cursor1 to Horiz Amplifier
x	x	1	1	x	x	x	x	Unassigned
0	0	x	x	x	x	x	x	Route Vert DAC to Vert Ampl
0	1	x	x	x	x	x	x	Route Vert DAC + Cursor0 to Vert Amplifier
1	0	x	x	x	x	x	x	Route Vert DAC + Cursor1 to Vert Amplifier
1	0	x	x	x	x	x	x	Route Horiz DAC to Vert Ampl

VERTICAL CURSOR MODE. The vertical output provides a ramp signal, locked to crt vertical screen position. The horizontal output matches the voltage of an analog cursor level control.

MIXER OPERATION. The readout system displays text in a pixel-type representation. For example, an underlined letter "A" may be represented as in Figure 3-9. Blackened spaces in the illustration denote a displayed pixel.

For each character, one pixel at a time is displayed by driving the vertical and horizontal outputs to values representing the vertical and horizontal position of a pixel within the character and then unblanking the Z-Axis.

Multiplexers U2414 and U2415 are ganged electronic switches that mix current and voltage settings. Vertical Readout DAC U2412 (vertical text generator) provides an output current from pin 2 that is proportionate to the vertical position of the pixel being displayed; the minimum output is 0 mA. Horizontal Readout DAC U2413 (horizontal text generator) provides an output current that is proportionate to the horizontal position of the pixel being displayed. Its minimum output is also 0 mA. The REF CURSOR and DELTA CURSOR levels are voltages that offset the text output for the type of cursor being displayed (vertical TIME cursors or horizontal VOLTS cursors). When straight text is to be displayed, dc levels for offsetting the vertical and horizontal text display outputs are added. Horizontal and vertical signals to be mixed for a particular readout are selected by the MIX0-3 outputs of latch U2411. The data is latched from

the Readout Processor bus when MIX STB clock is generated by the Readout Processor.

Output Buffers

The Output Buffers (U2416A and U2416D—vertical, and U2416B and U2416C—horizontal) are voltage follower circuits that mix the signals selected by the Readout Position Multiplexers and buffer them for application to the vertical delay line (RO VERT) and the Horizontal Preamplifier (RO HORIZ).

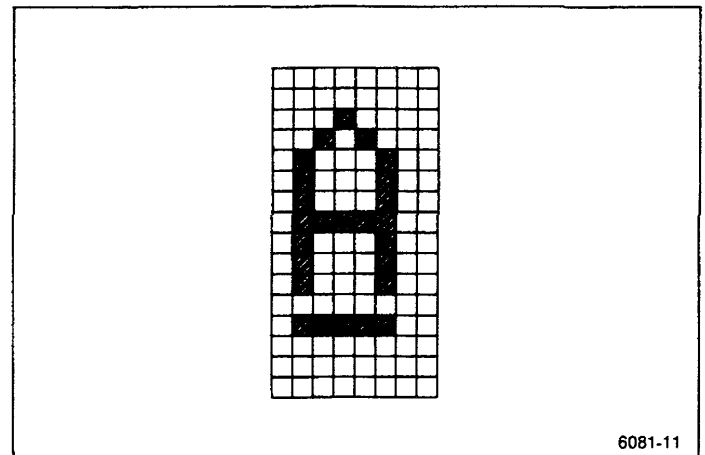

Figure 3-9. Character pixel arrangement.

The voltage at U2416 pin 14 depends on two things: the current from U2414 pin 13, and the voltage at U2414 pin 3. The possible displays are given in Table 3-29.

The voltage at U2416 pin 8 depends on two things: the current from U2415 pin 13, and the voltage at U2415 pin 3. The possible conditions are shown in Table 3-30.

Table 3-29
Display Possibilities

Readout Type	U2414-3	U2414-13
Stationary Text	0.6 V	U2412 output
Horizontal Ref Cursor	REF CURSOR	U2412 output
Horizontal Delta Cursor	DELTA CURSOR	U2412 output
Vertical Ref Cursor	0.6 V	U2413 output
Vertical Delta Cursor	0.6 V	U2413 output

Table 3-30
Possible Signal Conditions to U2416

Readout Type	U2415-3	U2415-13
Stationary Text	2.0 V	U2413 output
Horizontal Ref Cursor	2.0 V	U2413 output
Horizontal Delta Cursor	2.0 V	U2413 output
Vertical Ref Cursor	REF CURSOR	0 mA
Vertical Delta Cursor	DELTA CURSOR	0 mA

SWITCH BOARD AND INTERFACE (Diagram 10)

The front panel LEDs that backlight the switches and panel labels are schematically arranged in a matrix of eight rows and six columns. The front panel switches are arranged in a matrix of 16 rows and six columns. Each LED and switch is connected to a distinct row/column intersection, with a column of LEDs and a column of switches being common and enabled by the same signal.

At intervals of about 2 ms, a column of LEDs is refreshed (appropriate LEDs in column are turned on) and the status (open or closed) of the connected column of switches is read. All six columns of LEDs and the six columns of switches are completely refreshed and checked every 12 ms. The timing is fast enough to prevent flicker of the LEDs and to catch a momentary push button closure.

LED Refresh

Assume LED column AS0 is being refreshed. First, the LED Cathode Register, U2524, is loaded with a data byte from the Measurement Processor. That byte defines the LEDs that are on for that column, and the outputs of Cathode Driver U2525 for the "on" LEDs are low. Then, a high on the D0 bit of the Measurement Processor Data Bus is latched into LED Anode Register U2523 with the LED ANODE CLK signal. That high turns on the associated Darlington transistor (Q2506 for the AS0 column), and the LEDs in that column that also have their cathodes low from U2525 are turned on.

Switch Reading

At the same time the AS0 LED column is refreshed, the connected AS0 switch column is pulled high through CR2006. The switch status (low for open or high for closed) for the active switch column is parallel loaded into the Switch Board Shift Registers (U2001 and U2002). This switch status data is then shifted out serially (by 15 SW BD SR SHIFT clocks) to the Measurement Processor on the SW BD DATA return line. The position of a high in the serial data stream, and knowing the active column, tells the Measurement Processor the switch in column AS0 that is closed (the CH 1 VOLTS/DIV setting). Columns with push-button switches may or may not have a switch closed. A switch closure is interpreted by the Measurement Processor, and any new operating conditions needed (determined from the firmware routines called up to handle a particular switch closure) are set up.

At the next 2 ms interrupt, the Measurement Processor loads new data into Cathode Register U2524 to enable the LED rows, and the column is advanced to enable the AS1 column for refresh and switch reading. The process described is continual while the oscilloscope is on.

Part of the Measurement Processor routine stores the new front panel settings in the System RAM each time a change is made. At power on (after being turned off), the stored front panel settings are recalled from the System RAM to return the oscilloscope to the same operating state that existed at power off (with some exceptions).

Diagnostic

When the Measurement Processor is running the register checks during the DIAGNOSTIC, it can check the condition of registers U2001 and U2002. Serial data is placed on the AS0 line from the D0 bit of the

Measurement Processor data bus. That data is serially shifted through the two registers to the SW BD DATA return line. The Measurement Processor compares the returned data stream with what was sent. A difference in the data bits shows an error; a correct comparison passes the test.

ADC AND DAC SYSTEM (Diagram 11)

The ADC and DAC System permits the Measurement Processor to provide analog control voltages to the circuitry under its control and to determine analog voltage levels that it must have to do its control and measurement functions.

Pot Multiplexer Latch

Latch U2313 latches data from the data bus (D0–D7) to control multiplexers U2308 and U2309 on this diagram and U506 on Diagram 7.

Front Panel Control Multiplexers

Multiplexers U2308 and U2309, controlled by the Measurement Processor via Pot Mux Latch U2313, select the front panel control levels that are compared with the output of the D-to-A Converter (U2302). The result of that comparison is sent via signal line AD COMP to the Measurement Processor (U2501, Diagram 8).

Input Data Latches

Binary data bytes to be converted to analog voltages are loaded into two latches (U2300 and U2301). Data Latch U2301 latches data to the DAC Multiplexer (U2303). Data Latch U2300 latches data to the D-to-A Converter (U2302).

Digital-to-Analog Converter

The D-to-A Converter (U2302) using eight data bits can produce 256 discrete output signal current levels from 0 to 2 mA. Signal current flows through R2303 to the +2.5 V reference voltage. The resulting voltage drop across the resistor moves the voltage at pin 3 of voltage follower U2314 away from +2.5 V toward 0 V and below. When there is 0 mA output, the voltage at pin 3 is +2.5 V. At maximum output current, the voltage at pin 3 is –2.5 V.

A-TO-D CONVERSION. The output from U2314 is also applied to A-to-D Comparator U2306. When analog-to-digital conversion is being done, the Measurement

Processor drives the DAC to produce comparison voltage levels in a binary search pattern. The output of U2306 is monitored to determine the smallest DAC input change that will produce an output change from the comparator. That value is then used as the digital representation of the analog voltage applied to the other pin of the comparator from the output of Multiplexer U2308 or U2309. Signals on that multiplexed line are the front panel potentiometers wiper voltages and the probe code levels.

COUNTER/TIMER (Diagram 12)

The Counter/Timer (C/T) circuitry includes: a 10 MHz Oscillator, an External Time Base Input, Slow Counter Logic (SCL), Fast Counter Logic (FCL), Level Translators, and a Phase-Locked Loop (PLL) operation.

10 MHz Crystal Oscillator

This circuit consists of Q1901, Q1902, Y1901, R1901–R1905, and C1901–C1904. Q1901 and its various biasing and load resistors form the gain stage of an oscillator circuit. Y1901 is the resonant feedback element that, along with C1901, C1902, and C1904, determines the frequency of oscillation. Q1902 and R1905 form an emitter-follower buffer for driving U1902.

External Time Base Input

This circuit consists of J1902, C1906, R1906–R1910, CR1901, CR1902, and U1901. C1906, R1906, R1907, and the two diodes ac-couple and clamp the input to the high-speed comparator U1901. R1908–R1910 provide some hysteresis for the comparator for noise immunity. This hysteresis band is approximately 320 mV, centered around ground. When nothing is connected to J1902, the hysteresis will prevent the comparator from toggling randomly. The comparator output is TTL compatible and drives the TC2 input (pin 2) of U1902 (SCL).

Slow Counter Logic (SCL)

This is a CMOS logic circuit that combines the C/T's slower logic circuitry into one IC (U1902). IC U1902 contains an interface for communicating with the Processor (U2501, diagram 8), three count chains, an automatic time base selector and scaler, a pseudo-random noise generator, a phase-frequency comparator, and part of the phase-locked loop (PLL) frequency divider.

The microprocessor interface provides the capability to write an 8-bit control word to SCL, read out the three

count chains, read the overflow status bits, clear the overflow status bits, and interface to the fast-logic half (U1905) of the counter subsystem (through pins 30–39 on U1902).

The three count chains consist of two 19-bit binary up-counters (A and B) and one 15-bit binary up-counter (C). The contents of these counters may be read out one byte at a time through the microprocessor interface. The fast-logic half of the counter contains the high-speed sections of these count chains, and the microprocessor interface is used to read out the high-speed sections as well.

There are two PLL components in the SCL IC. The frequency divider scales the voltage-controlled oscillator (VCO) input by ten and provides a square wave to one input of the phase/frequency comparator (PFC). The PFC compares this signal to the 1 MHz reference signal provided by the auto-time-base selector/scaler (ATSS) and generates a signal that, when filtered externally, indicates the phase or frequency relationship between the VCO and the time-base reference. (See Phase-Locked Loop Operation.)

The pseudo-random noise generator (PRNG) is a 17-stage feedback shift register which provides a pseudo-randomly switching waveform that is used to phase-modulate the PLL during time-interval measurements. This shift register is clocked by a 125 kHz signal that is produced by dividing the 1 MHz reference from the time-base scaler output by eight. The period of the pseudo-random waveform is about one second.

The PRNG is only enabled for time-interval measurements such as width and rise/fall. It is not needed for frequency and period measurements, so the NOISE output (pin 22) on SCL will remain near ground for these measurements. When a time-interval measurement is active, this output will toggle between ground and V_{DD} .

The ATSS provides a reference signal for the PFC. If no external time base is connected to the TC2 input, the 10 MHz signal provided on the TC1 input is scaled by ten and sent to the PFC. If a 10 MHz, 5 MHz, or 1 MHz signal is connected to the TC2 input, the ATSS will automatically switch to it and scale it down to 1 MHz. A 10 MHz signal must be connected to the TC1 input for the ATSS to work properly. If a signal other than 1, 5, or 10 MHz ($\pm 2\%$) is connected to TC2, the ATSS will not work properly, and therefore the PLL and the Counter/Timer will not work properly.

Fast Counter Logic (FCL)

FCL performs the fast logic functions for the Counter/Timer subsystem. IC U1905 contains a control interface, three count chains, part of the phase-locked-loop (PLL) frequency divider, trigger input mux, measurement gating block, and output mux.

The control interface provides the capability to write control bits and reset the measurement gating block and count chains. The Measurement Processor accesses this interface through SCL pins 34–39. There are three address lines (A0, A1, and A2) for selecting a particular register inside FCL, two data lines (ID0 and ID1) to provide the data to be written into the selected register, and a write line (WR) to strobe the data into the register.

The three count chains consist of two 5-bit binary up-counters (A and B) and one 1-bit binary up-counter (the C counter, that resides in the measurement gating block). The fifth stage (MSB) of the A and B counters drives the AOUT and BOUT output pins, which in turn clock the A and B count chains in SCL on falling edges. The C counter drives the COUT output pin directly, which in turn clocks the C count chain in SCL on falling edges. In effect, the A and B counters are each a total of 24 bits long, and the C counter is a total of 16 bits long. The lower four stages of the A and B counters are read out through the output mux by the Measurement Processor.

The PLL frequency divider scales the TC input by 20. Normally, 200 MHz is presented on the TC input. The TC10 output provides a 10 MHz square wave.

The trigger input mux selects TRIG, AUX, or NAGATE as a trigger source for the measurement gating block. The measurement gating block triggers on the positive edge of TRIG or the negative edges of AUX and NAGATE.

The measurement gating block accepts a trigger signal from the trigger input mux, control signals from the control interface, various arming signals, and provides clock signals to the count chains and status signals to the output mux.

The output mux provides a way for the microprocessor to read out (via the SCL) the lower four bits of the A and B count chains and the measurement gating block status.

Level Translators

The resistor network, consisting of R1911–R1916, R1917, and R1918, provides level translation between SCL output pins 34–39 and FCL input pins 27–32. The SCL outputs provide GND to V_{DD} signal swings, which get attenuated and level-shifted to swings about + 2.7 V

to +4.3 V by the resistor network. When ECL circuitry is powered from a +5 V supply, the “correct” output swing should be about +3.4 V to +4.3 V. Inputs to ECL circuitry running on a +5 V supply should not go much higher than +4.3 V, or the ECL input could saturate, causing a slowdown of the logic. It is all right for the input swing to go below the “legal” ECL low of +3.4 V.

It is more difficult to translate from ECL outputs to TTL inputs. In this case, voltage gain is needed. FCL output pins 11–14 (output data mux), AOUT, BOUT, COUT, and TC10 all need to be translated up to TTL levels. This is done with U1903 and U1904. However, the input common-mode range for these comparators is specified as ± 3.0 V, and the ECL output swing is about +3.4 V to +4.3 V, so R1919–R1927 level shift the ECL output signals so they toggle between approximately +1.9 V and +2.8 V.

Phase-Locked Loop (PLL) Operation

OPERATION. The PLL consists of the phase-frequency comparator (PFC), summer, loop filter, voltage-controlled oscillator (VCO), and frequency divider (parts of which are in SCL and FCL). The divider divides the VCO output (normally 200 MHz) by a factor of 200. The PFC compares the 1 MHz reference signal to the output of the frequency divider. When power is first applied to this circuit, there will be a frequency difference, which will cause the PFC to output pulses to the summer, which in turn passes them on to the loop filter. The loop filter averages these pulses and outputs a mostly dc signal to the control input of the VCO. The DC signal from the filter will pull the divided VCO frequency up or down (depending on which frequency was higher) to make it equal to the 1 MHz reference frequency. When the frequencies become equal, the PFC will output a pulse whose duty factor is dependent on the phase difference. Since this is a closed-loop feedback system, the circuit stabilizes at a particular phase difference. Any component drift in the VCO will cause automatic correction by the PFC.

SUMMER. The summer adds the PFC output to the filtered and attenuated noise signal from SCL. C1909, C1910, R1931, and R1932 provide this filtering and attenuation. This processed noise signal is added through R1933 to the PFC signal (which comes through R1930). When the NOISE output of SCL is enabled, the processed noise signal causes small variations in phase, which improve the time-interval averaging capabilities of the C/T.

LOOP FILTER. The loop filter consists of R1934 and C1911. R1935 provides some negative bias to the VCO

input, to control the phase difference that the PLL stabilizes on.

VCO. The Voltage-Controlled Oscillator consists of the rest of the circuitry from R1936 to Q1903. This circuit is basically a grounded-base Colpitts oscillator. Its frequency of oscillation is determined by C1912–C1914, L1901, and CR1903 (a variable capacitance diode). As the voltage on the diode’s cathode gets more positive, its capacitance gets smaller, and the oscillator frequency gets higher. Normally, the cathode voltage is around +2 V to +3 V when the PLL is working properly, but can vary slightly, depending on actual component values.

Finally, C1916, R1939, and R1940 couple the 200 MHz signal to FCL pin 58. This network guarantees that the signal swing is appropriate for the ECL input.

DAC SUBSYSTEM (Diagram 13)

Dac Refresh Processor

The Dac Refresh Processor (U2601) is an eight-bit microcomputer containing its own internal memory. The job of this processor is to refresh the D-to-A Converter (U2602) with the front panel control levels that have been loaded into the Dac Processor memory from the Measurement Processor.

Binary values for the front panel control settings from the Measurement Processor are loaded via DAC0–DAC7 into the Dac Refresh Processor (U2601) memory. Whenever the Measurement Processor has determined that a control value has changed, it updates the Dac Processor memory with the new value. The Dac Processor continuously sends the front-control binary values to the Digital-to-Analog converter (U2602) and multiplexes the resulting analog signals to the individual control circuits.

Digital-to-Analog Converter

The D-to-A Converter (U2602) has 12-bit resolution that can produce 4096 discrete output signal current levels from 0 to 2 mA. Signal current flows through R2603 to the +2.5 V reference voltage. The resulting voltage drop across the resistor moves the voltage at pin 5 of voltage follower U2609B away from +2.5 V toward 0 V and below. When there is 0 mA output, the voltage at pin 5 is +2.5 V. At maximum output current, the voltage at pin 5 is –2.5 V. Voltage Follower U2609B buffers the voltage and applies it to the control circuit selected by the Measurement Processor.

Control Multiplexers

Analog voltage levels from the D-to-A Converter U2602 are multiplexed to the individual front panel control circuits. Three multiplexers, U2604 and U2605 on this diagram and U2303 on Diagram 11 handle all of the potentiometer controlled circuits in the instrument (except FOCUS and SCALE ILLUM which are not digitized).

Sample-and-Hold Circuits

The analog voltages from multiplexers U2303, U2604, and U2605 remain stable only for the short period of time that the DAC is at a fixed output level. Control voltages to the analog circuitry must remain constant except for changes to the control settings. Those control voltages are held constant between refreshes by sample-and-hold circuits formed by a capacitor (to hold the voltage) and a voltage follower (to buffer the voltage held by the capacitor). The voltage follower circuits are provided by the operational amplifiers of U2304, U2305, U2606, U2607, and U2608. Extra noise filtering for two of the control voltages (REF DELAY and DELTA DELAY) is provided by using an RC pi-type filter input circuit to the voltage follower.

POWER SUPPLY (Diagram 14)

The Power Supply (Diagram 13) provides the various low voltages needed to operate the 2247A and the high voltage required by the cathode-ray tube (crt). The supply circuitry is arranged in the following functional blocks: Ac Input, Primary Power Rectifier, Start-Up circuit, Preregulator Control circuit, Preregulator Power Switching circuit, Inverter Control circuit, Inverter Power Switching circuit, Low-Voltage Secondary Supplies, and High-Voltage Supply (see Figure 3-10).

Ac power via the power cord is rectified and filtered by the Primary Power Rectifier to supply the dc voltage to Preregulator circuitry. The output voltage level from the Primary Power Rectifier depends on the ac supply voltage level and may vary between about 125 V and 350 V. This unregulated, filtered, dc voltage is supplied to the Preregulator Start-Up circuit and the Preregulator Switching circuit. The Preregulator Power Switching circuit supplies +44 Vdc output power to drive the Inverter Power Switching circuit.

The +44 V Preregulator output voltage is switched by the Inverter Power Switching circuit to produce an alternating current through the primary of the Inverter power

transformer. The voltage across the primary of the inverter transformer is monitored and regulated by the Inverter Control circuit to maintain a constant output voltage level across the transformer secondaries.

The Low-Voltage Secondary Supplies rectify and filter the low-voltage secondary ac voltages to provide the dc power requirements for the instrument. Two other secondary windings on the Inverter Power Transformer are used in the High-Voltage Supply, a high-voltage winding and a crt filament winding. Voltage from the high-voltage winding is further multiplied and converted to dc voltage for the crt anode, cathode, and intensity-grid voltages.

Both overvoltage and overcurrent protection are provided to protect the oscilloscope circuitry from further damage if a circuit component fails.

Ac Input

Applied source voltage is input to the Primary Power Rectifier via surge protection circuitry and noise filtering circuitry. A sealed line filter (FL2201), L2207, L2208, C2214, C2213, C2216, C2215, R2260, R2227, and R2228 form a low-pass filter designed to prevent transmission of high-frequency noise signals either into or out of the instrument. Bleeder resistor R2215 across the input line filter drains off any charge retained by the capacitors in the input circuitry when the power is disconnected. Thermistor RT2201 prevents a sudden rush of input current into the rectifier and filter capacitor, C2202, when the power switch is turned on. The thermistor presents a relatively high resistance when cold, then quickly reduces to a low value when warmed up. Varistor VR2204 acts as a surge limiter to reduce the effects of any power line surges that may damage the input circuit components. The varistor is a voltage-sensitive device that quickly reduces its resistance value when its voltage limits are exceeded. Line fuse F2201 protects the instrument from additional damage in case of a severe short in the power supply.

Primary Power Rectifier

Rectification of the input ac source voltage is done by rectifiers CR2231-CR2234. Simple capacitive filtering of the rectifier output is done by C2202. The filtered output voltage may range between about 125 and 350 Vdc, depending on the amplitude of the ac input voltage. A line trigger signal is picked off by T2206 for use when the Trigger SOURCE is set to LINE. Bleeder resistor R2256 drains off the charge on C2202 when the instrument is turned off.

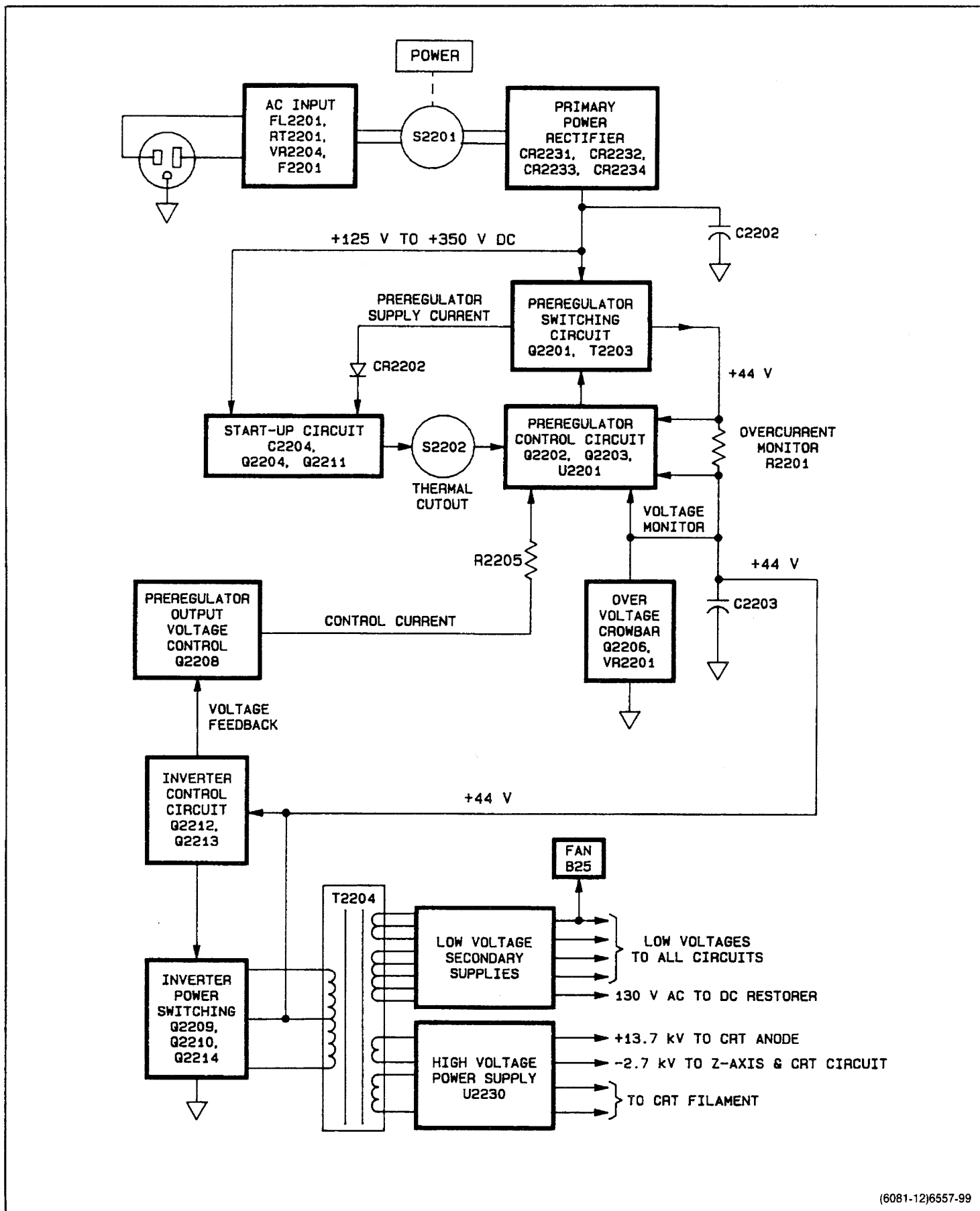

(6081-12)6557-99

Figure 3-10. Power Supply block diagram.

Start-Up Circuit

The Start-Up circuit provides the operating supply voltage to the Preregulator. At power on, C2204 in the Start-Up circuit begins charging through R2203 and R2204 from the output of the Primary Power Rectifier. When the voltage across C2204 reaches 20 V, the voltage at the base of Q2204 is about 6.8 V. This base voltage level causes Q2204 to conduct (there is a 6.2 V zener diode in the emitter path), and Q2211 also is then biased on. Positive feedback to the base of Q2204 (from the collector of Q2211 through R2220) then keeps both transistors on. The dc voltage to U2201 (Vcc) for start up (and continued running after start up) is provided by the charge on C2204 via Q2211.

With U2201 on and drawing current from C2204, the voltage across C2204 begins to fall. If the Preregulator output rises to +44 V before the voltage across C2204 falls to 10 V, then CR2202 becomes forward biased, and current pulses are supplied by a winding (pins 8 and 9) on T2203 to keep C2204 charged (and U2201 operating).

If the Preregulator output does not rise to +44 V within the time it takes to discharge C2204 below 10 V (about 1/10 of a second), the voltage at the base of Q2204 will drop too low for the feedback voltage to keep it on. That will cause Q2211 to also shut off. The start-up cycle repeats when the voltage across C2204 again reaches 20 V (recharging from the output of the Primary Power Rectifier output via R2203 and R2204). Continued failure of the Preregulator to start up and the repeated attempts to do so is called the "Chirp" mode. Zener diode VR2206 prevents the voltage across C2204 from exceeding about 30 V if no start-up attempt occurs.

Preregulator Control Circuit

The Preregulator Control IC, U2201, is a pulse-width modulator used to control the on time of Preregulator Switching FET Q2201. It contains an oscillator, comparators, voltage and current error amplifiers, and logic circuitry that controls its operation. The modulated output pulses drive switching transistor Q2201 through a buffer amplifier composed of Q2202 and Q2203. Pulse width (the time that FET Q2201 is on) is inversely proportional to the control voltage at pin 3 of U2201 (i.e., a lower voltage at pin 3 makes the pulse width wider to keep Q2201 on longer).

Pin 7 of U2201 is the IC ground reference, and it is tied directly to the +44 V output voltage. Therefore, the Preregulator IC and the Start-Up circuitry operating

potentials "float" on the regulated output voltage (developed across C2203).

Pin 2 of U2201 is the current-summing node to the voltage-error amplifier. The error amplifier will try to keep the voltage on pin 2 equal to the voltage on pin 1 (the +44 V supply voltage). The error amplifier maintains pin 2 at +44 V by raising (or lowering as necessary) the voltage at pin 3. This raises (or lowers) the voltage across C2203 so that less (or more) current will be drawn out of the current summing node.

The major current injected into the summing node is from the regulated 5 V output, from pin 12 of U2201, via R2212. That current is about 0.6 mA. The current through R2206 adds to the current shunted by the Preregulator Output Voltage Control transistor, Q2208, to produce about 0.6 mA to keep the current into and out of the summing node balanced. The actual current through R2206 is the output voltage (+44 V across C2203) divided by the resistance value of R2206 (100 k Ω) or about 0.4 mA.

SOFT START. At the initial turn-on of the instrument, C2203 is discharged. If no action were taken to prevent it, the initial charging current to that capacitor would exceed safe limits. To avoid such a problem, a "soft start" of the charging path is done.

At turn-on, the +5 V output of U2201 steps to +5 V immediately. A +5 V pulse is coupled to pin 4 of U2201 via C2207. This pin is the "dead time control" input, and when it is high, the dead time between switching pulses to Q2201 is increased to 100%. Switching transistor Q2201 does not turn on, and no charging of C2203 occurs. Then, as C2207 charges, the voltage on pin 4 begins to decrease toward the ground reference value (on pin 7). This decreases the dead time, allowing increasingly wider conduction pulses to occur.

The on-time gradually increases until the charging current is limited by the internal current limit amplifier of U2201. At that point, the Preregulator is acting as a current source. When the voltage across C2203 reaches +44 V, the voltage error amplifier starts to limit the output, and the Preregulator has reached its operating level and acts as a voltage source.

CURRENT LIMIT. The output current of the Preregulator switching FET, Q2201, is limited to a safe value. If the current exceeds 2.4 amperes, the voltage dropped across R2201 causes pin 14 of U2201 (one input of the current limit amplifier) to exceed the voltage on pin 13 of U2201 (the other input pin of the current limit amplifier). The output of the current limit amplifier then goes high, raising the voltage on pin 3 of U2201. Increased voltage

on pin 3 narrows the width of the turn-on pulses to switching FET Q2201 and limits the output current.

Usually, with a circuit failure, the excess loading remains, and the pulses remain narrow. The Preregulator Control IC then shuts down because the charge on C2204 is not maintained via the Preregulator supply winding on T2203, and the Preregulator goes into the chirp mode (continual shut down and restart attempts).

OVERVOLTAGE CROWBAR. If the output voltage across C2203 exceeds about +51 V, VR2201 in the crowbar circuit conducts. The gate of SCR Q2206 then rises; and, if the rise is enough, the SCR latches on. When on, Q2206 shorts out C2203, and the current limit circuit causes the switching pulses to Q2201 to become very narrow. Preregulator IC U2201 then shuts down (as described in the Current Limit discussion). The Preregulator will attempt a restart after about half a second, but will shut down again if the overvoltage condition continues (this is the “chirp” mode).

PREREGULATOR OUTPUT CONTROL. The voltage across the Inverter current source transistor, FET Q2214, is monitored by Q2208 (from the collector voltage of either Q2209 or Q2210). That voltage has to be maintained at the proper level to provide enough regulation room for the secondary supply voltages and still not dissipate more power than necessary in Q2214. If the voltage across Q2214 is too high, Q2209 is biased on harder and draws more current from the input summing node (pin 2 of U2201) of the voltage error amplifier in U2201, the Preregulator Control IC. The output of the error amplifier at pin 3 of U2201 then rises, and the width of the switching pulse to the Preregulator Switching circuit narrows to decrease the +44 V output.

The Inverter Control circuit (Q2212 and Q2213) senses the decreased voltage across the primary of the Inverter power transformer (T2204) and responds by driving Q2214, the Inverter current-source transistor, harder; thereby decreasing the voltage across it.

Control response time in the feedback loop just described is long; but it does not need a fast response time, since the circuit only determines the power dissipation in Q2214. Compensation of the circuit to prevent oscillation is done by a low-pass filter (10 Hz cutoff) formed by C2238, R2205, and R2246.

Preregulator Switching Circuit

The Preregulator Switching circuit provides the energy required to keep C2203 charged up to +44 V. Switching FET Q2201 is driven by the pulse-width modulated output of the Preregulator IC (U2201) via a buffer amplifier circuit. The Preregulator IC controls the on-time to maintain the voltage across C2203 at +44 V.

For the following discussion of the switching circuit, assume that Q2201 is off, C2201 is charged to the rectified line voltage (160 V from the Primary Power Rectifier), and the +44 V supply is up and driving a circuit load.

When the Preregulator IC turns on Q2201, the drain of Q2201 is immediately clamped to 44 V. This forces 116 V (160 V - 44 V) across pins 6 and 7 of T2203. Current begins increasing linearly in that coil as Q2201 supplies current to the +44 V supply. With the one end of C2201 clamped to +44 V, and C2201 being charged to +160 V, the other end of C2201 is pushed down with the anode of CR2201 going to -116 V (44 V - 160 V). This places 116 V (0 - 116 V) across pins 1 and 2 of T2203 and current begins increasing linearly in that coil, also flowing through Q2201 to the +44 V supply. After a time determined by Preregulator IC U2201, the drive signal to Q2201 is switched low, and the switching FET is turned off.

The current flowing in both coils of T2203 must continue as the magnetic field collapses, but it cannot flow through Q2201. The only available path is through CR2201 (previously biased off). The polarity reversal of the voltage across T2203 that occurs forward biases CR2201, and permits the energy in the magnetic field to be released to the +44 V supply.

When CR2201 is forward biased its cathode is clamped to the +44 V supply level. With C2201 still charged to +160 V (the supply voltage), its positive end is pushed up to 204 V (44 V + 160 V). Now there is -44 V (160 V - 204 V) across the coil of T2203 from pin 6 to pin 7 and -44 V (0 - 44 V) from pin 1 to pin 2 (see Figure 3-11). Since C2201 is in parallel with C2202 for dc voltages (coils are shorts to dc), the dc voltage across C2201 can change very little. The capacitance of C2201 is large enough that the charging and discharging currents do not have enough time to change the voltage across C2201 in normal operation.

The two coils of T2203 need not be coupled magnetically for the circuit to operate. Both coils are wound on the same core for convenience. Transformer action is minimal because the waveforms impressed across both coils are nearly identical.

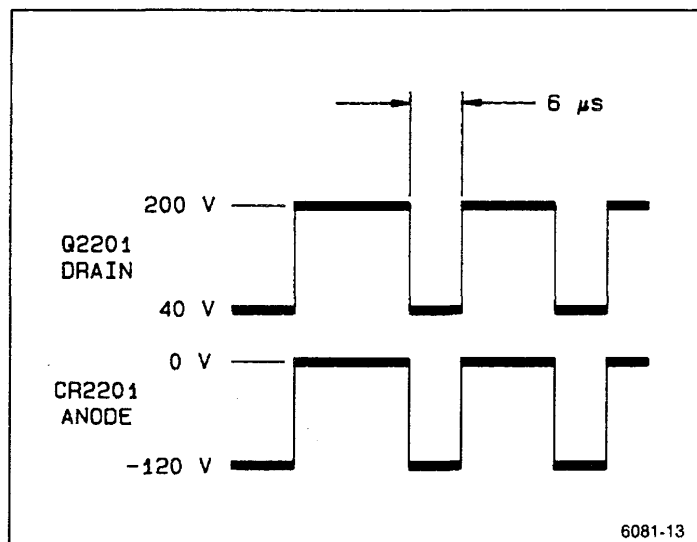

Figure 3-11. Preregulator switching waveforms.

After a time controlled by the Preregulator IC (the dead time), the on-time cycle for Q2201 repeats. On time depends on the line voltage level; a higher line voltage level means a shorter on time of Q2201 is needed to maintain +44 V across C2203.

Inverter Power Switching Circuit

The Inverter Power Switching circuit is composed of switching transistors Q2209 and Q2210, current source transistor Q2214, inverter power transformer T2204, base-drive transformer T2205, and associated components. Current supplied by the +44 volts output from the Preregulator circuit is alternately switched through each side of the center-tapped primary of T2204 to drive the loads on the secondary windings of the inverter transformer.

INVERTER STARTER. As the Preregulator turns on, the +44 V supply increases from 0 V. The increasing voltage forward biases CR2236 and charges C2248 through the base-emitter junctions of Q2209 and Q2210. Current is drawn through each side of T2204, from the center tap, as the transistors conduct. One of the two transistors will have a slightly higher gain than the other, and its collector voltage will decrease more than the other. The voltage difference across the primary of T2204 also appears across the primary winding of T2205, and a feedback voltage is induced in the secondary winding of T2204. The polarity of the transformer is such that the conduction of the higher gain transistor is reinforced (positive feedback), and that transistor quickly saturates while the other is cut off. One end of the primary of T2204 is driven toward ground while the other end is opened. After about half a second, C2248

charges up, CR2236 becomes reverse biased, and that path for current through the conducting transistor is blocked.

If the Inverter Power Switching circuit stops, the Inverter Starter circuit will not restart it until C2248 is discharged. Furthermore, C2248 will not discharge until the +44 V supply falls.

INVERTER POWER SWITCHING. Switching is started by one or the other of either Q2209 or Q2210 conducting more than the other, and circuit action biases the other one off. Assume for this discussion that Q2210 is biased on and Q2214 is off. Current flows through current-source FET Q2214, on-transistor Q2210, and half of the primary of T2204 (pins 9 and 11). The voltage drop across current-source transistor Q2214 holds the emitter voltage of Q2209 and Q2210 at 3 V. Voltage across pins 9 and 11 is therefore 41 V (44 V - 3 V).

Through autotransformer action, 41 V is induced in the other half of the primary winding of T2204 from pin 8 to the center-tap pin. That voltage adds to the 41 V from pins 9 to 11 to produce a potential of 82 volts across the primary of switching transformer T2205. Current rapidly ramps up through the primary of T2205 and induces a positive feedback base current in one-half of its center-tapped secondary that keeps Q2210 turned on. Current in the other half of the secondary biases on CR2227 to prevent a high reverse base-to-emitter voltage from being developed across Q2209.

After about 25 μ s, the current through the primary of T2205 saturates the magnetic core and the primary impedance of the transformer drops to a low value. When saturation occurs, the impedance presented by L2206 by comparison to that of T2205 is large, and most of the voltage applied from the secondary of T2204 is then dropped across L2206. The secondary voltage of T2205 drops to zero, and with no base-drive current to Q2210, that transistor switches off.

With both Q2209 and Q2210 off, the magnetic energy stored in the primary of T2205 and in L2206 causes current to flow in the primary of T2204, reversing the voltage polarity on this winding. The voltage reversal is not instantaneous because of the parasitic capacitance of the T2204 windings. When the reverse voltage gets high enough, base current flows to Q2209 and that transistor turns on. The inverter current flow cycle through T2204 then repeats but in the opposite direction to induce ac current in the various secondary windings of the inverter power transformer.

INVERTER CONTROL LOOP. Whenever either Q2209 or Q2210 is on, the collector voltage of the on transistor forward biases either CR2205 (if Q2209 is on) or CR2204 (if Q2210 is on). Capacitor C2219 is then charged to nearly the same voltage that is applied across each half of the primary winding of Inverter Transformer T2204.

A resistive voltage divider formed by R2239, R2238, and potentiometer R2252 (+7.5 V ADJUST) applies a fraction of the voltage across C2219 to the base of Q2213 (one-half of a differential amplifier formed by Q2212 and Q2213). The voltage on the base of Q2213 is compared to a voltage on the base of Q2212 that is referenced back to the +44 V center tap voltage of T2204. If the collector voltage of the conducting inverter switching transistor (Q2009 or Q2210) is not the correct level (about 3 V), the gate voltage of current-source FET Q2214 will be raised or lowered as needed to correct the error.

Low-Voltage Secondary Supplies

The low-voltage power supply circuitry on the pin 12 to pin 22 and pin 13 to pin 15 secondary windings of the Inverter power transformer consist of rectifier and filter components only. All the regulation is done by the Preregulator and Inverter Control circuitry in the primary side of the transformer. Both half-wave and full-wave rectifiers are used, and either simple capacitor or capacitive-input PI filter circuits are used. Rectifier and filter type used for each of the secondary voltages depends on the load requirement. A single 130 Vac output from pin 12 of T2204 supplies the drive to the Z-Axis dc restorer circuitry. Power for the blower fan is supplied by the -15 V power supply line.

The center-tapped secondary winding from pins 13 to 15 of T2204 is used for the +5 V and -5 V supplies. Both are full-wave rectified and filtered using capacitive-input PI filters.

High-Voltage Supply

The high-voltage power supply uses two secondary windings of T2204: one for high-voltage multiplier U2230 and the other for the crt filament. Flying leads from the top of the transformer make the circuit connections

into the high-voltage circuitry. The crt filament winding consists of a few turns of insulated wire.

The high-voltage winding attaches directly to the HV Multiplier. Outputs from HV Multiplier U2230 are the 13.7 kV to the crt anode via a high-voltage-insulated connecting lead and the -2.7 kV supplied to the crt cathode, focus grid, and intensity grid. The -2.7 kV supply is filtered by a two-section capacitive input RC filter. A neon lamp across the second section of the filter provides protection against arcing if there is a failure that can cause a large difference of potential to develop between the crt heater and cathode circuits.

MAIN BOARD POWER DISTRIBUTION (Diagram 15)

The Main Board Power Distribution diagram schematically displays the distribution paths and decoupling circuits for the low voltages from the Power Supply. The supply and ground connections to the various integrated circuits in the instrument are also shown. Use this diagram to aid circuit tracing when trying to locate a power supply loading problem associated with the Main Board.

PROCESSOR BOARD POWER DISTRIBUTION (Diagram 16)

The continuing power distribution from the Main Board to the top board (Processor Board, A16) is shown in the Processor Board Power Distribution schematic diagram. Use this diagram to aid in locating power supply loading problems that are isolated to the Processor Board.

INTERCONNECTION DIAGRAM (Diagram 17)

Circuit board interconnections with the plug, jack, pin numbers, and signal names shown are found in schematic Diagram 17. The diagram is useful in checking continuity of cable runs and signal paths from board to board through the instrument.

*This Document is a complete Scan from the original
Tektronix manual*

*For enquiries about our complete
High quality line of technical Manuals in PDF*

mailto : Qservice@otenet.gr

**SEE
OTHER
SIDE**

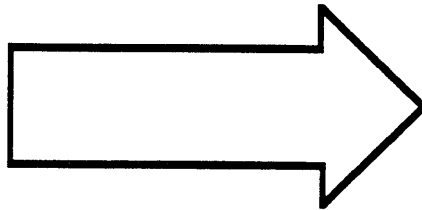

PERFORMANCE CHECK PROCEDURE

INTRODUCTION

This Performance Check Procedure verifies the Performance Requirements of the 2247A as listed in the Specification (section 1) and helps determine the need for readjustment. These checks may also be used as an acceptance test or as a troubleshooting aid.

You do not have to remove the wrap-around cabinet from the 2247A to do this procedure. All checks can be made with controls and connectors accessible from the outside.

TEST EQUIPMENT REQUIRED

Table 4-1 lists all the test equipment required for both the Performance Check Procedure in this section and the Adjustment Procedure in Section 5. Test equipment specifications described are the minimum necessary to provide accurate results. For test equipment operating information, refer to the appropriate test equipment instruction manual.

When you use equipment other than that recommended, you may have to make some changes to the test setups. If the "Example of Test Equipment" given in Table 4-1 is not available, use the "Minimum Specification" column to determine if any other available test equipment might be adequate to do the check.

PERFORMANCE CHECK INTERVAL

To ensure instrument accuracy, check the performance of the 2247A after every 2000 hours of operation (or once each year if used infrequently). If the checks indicate a

need for readjustment or repair, refer the instrument to a qualified service person.

PREPARATION

This procedure is divided into subsections to let you check individual sections of the instrument when it is not necessary to do the complete Performance Check. An Equipment Required block at the beginning of each subsection lists the equipment from Table 4-1 that is needed to do the checks in that subsection.

The initial front-panel control settings at the beginning of each subsection prepare the instrument for the first step of the subsection. Do each of the steps in a subsection completely and in the order given, to ensure the correct control settings for steps that follow. To ensure performance accuracies stated in Table 1-1 (Electrical Characteristics), let the instrument warm up for 20 minutes and run the SELF CAL MEASUREMENTS routine.

To run the SELF CAL MEASUREMENTS routine:

Press the top and bottom menu-item select buttons to display the SERVICE MENU. Underline and select SELF CAL MEASUREMENTS. Press RUN to start the routine, then QUIT to return to the normal oscilloscope mode.

NOTE

Performance accuracies are ensured only when the SELF CAL MEASUREMENTS routine is done AFTER the 20-minute warmup.

Table 4-1
Test Equipment Required

Item and Description	Minimum Specification	Use	Example of Test Equipment
Leveled Sine-Wave Generator	Frequency: 250 kHz to above 150 MHz. Output amplitude: variable from 10 mV to 5 V p-p. Output impedance: 50 Ω . Amplitude accuracy: constant within 1.5% of reference frequency to 100 MHz.	Vertical, horizontal, triggering, measurement bandwidth, and Z-Axis checks and adjustments. Counter/Timer checks.	TEKTRONIX SG 503 Leveled Sine-Wave Generator. ^a
Calibration Generator	Standard-amplitude signal levels (dc and square wave): 5 mV to 50 V. Accuracy: $\pm 0.25\%$. High-amplitude signal levels: 1 V to 60 V. Repetition rate: 1 kHz. Fast-rise signal level: 1 V. Repetition rate: 1 MHz. Rise time: 1 ns or less. Flatness: $\pm 0.5\%$.	Signal source for gain and transient response checks and adjustments.	TEKTRONIX PG 506 Calibration Generator. ^a
Time-Mark Generator	Markers: 5 ns to 2 s in a 1-2-5 sequence. Accuracy: $\pm 0.00005\%$.	Counter/Timer and horizontal checks and adjustments. Display adjustment. Time cursor checks.	TEKTRONIX TG 501 Option 01 (Precision Time Base) Time-Mark Generator. ^a
Function Generator	Range: less than 1 Hz to 1 kHz; sinusoidal output; amplitude variable up to greater than 10 V p-p open circuit with dc offset adjust.	Low-frequency checks.	TEKTRONIX FG 502 Function Generator. ^a
Coaxial Cable (2 required)	Impedance: 50 Ω . Length: 42 in. Connectors: BNC.	Signal interconnection.	Tektronix Part Number 012-0057-01.
Precision Coaxial Cable (3 required)	Impedance: 50 Ω . Length: 36 in. Connectors: BNC.	Used with PG 506 Calibration Generator and SG 503 Sine-Wave Generator.	Tektronix Part Number 012-0482-00.

^aRequires a TM500-series power module.

Table 4-1 (cont)

Item and Description	Minimum Specification	Use	Example of Test Equipment
Termination (3 required)	Impedance: 50 Ω . Connectors: BNC.	Signal termination.	Tektronix Part Number 011-0049-01.
10X Attenuator	Ratio: 10X. Impedance: 50 Ω . Connectors: BNC.	Triggering checks.	Tektronix Part Number 011-0059-02.
2X Attenuator	Ratio: 2X. Impedance: 50 Ω . Connectors: BNC.	Triggering checks.	Tektronix Part Number 011-0069-02.
Alignment Tool	Length: 1-in shaft. Bit size: 3/32 in. Low capacitance; insulated.	Adjust TRACE ROTATION pot. Adjust variable capacitors and resistors.	Tektronix Part Number 003-0675-00.
Test Oscilloscope	Bandwidth: 20 MHz.	Z-Axis response adjustment.	TEKTRONIX 2246A.
Dual-Input Coupler	Connectors: BNC female-to-dual-BNC male.	Signal interconnection.	Tektronix Part Number 067-0525-01.
T-Connector	Connectors, BNC.	Signal interconnection.	Tektronix Part Number 103-0030-00.
Precision Normalizer	Input resistance: 1 M Ω . Input capacitance: 20 pF.	Input capacitance adjustments.	Tektronix Part Number 067-1129-00.
TV Signal Generator	Provide composite TV video and line sync signals.	Check TV Trigger circuit.	Tektronix TSG-100 Test Signal Generator.
Digital Multimeter (DMM)	Dc volts range: 0 to 140 V. Dc voltage accuracy $\pm 0.15\%$. 4 1/2 digit display.	Power supply voltage checks and adjustments.	Tektronix DM 501A Digital Multimeter. ^a
Digital Delay	Count: 10 to 99,999 events. Sensitivity: 85 mV p-p at 30 MHz. Minimum detect- able pulse width: 5 ns.	Counter/Timer checks.	TEKTRONIX DD 501 Digital Delay. ^a
BNC Coupling Capacitor	0.047 μ F.	Voltmeter dc volts normal mode rejection ratio check.	Tektronix Part Number 015-0221-00.

^aRequires a TM500-series power module.

INDEX TO PERFORMANCE CHECK PROCEDURE

Display

1. TRACE ROTATION 4-5
2. Geometry 4-5

Vertical

1. Input COUPLING Functional Check 4-6
2. CH 1 and CH 2 VOLTS/DIV
Trace Shift 4-6
3. CH 3 and CH 4 VOLTS/DIV
Trace Shift 4-7
4. CH 1 and CH 2 VAR VOLTS/DIV
Trace Shift 4-7
5. CH 1 and CH 2 Input COUPLING
Trace Shift 4-7
6. CH 2 INVERT Trace Shift 4-7
7. CH 1 and CH 2 VAR VOLTS/DIV
Range 4-7
8. Low Frequency Linearity Check 4-8
9. CH 1 and CH 2 Vertical Deflection
Accuracy 4-8
10. CH 3 and CH 4 Vertical Deflection
Accuracy 4-8
11. ADD Mode and CH 2 INVERT
Deflection Accuracy 4-9
12. Vertical POSITION Range
(all channels) 4-9
13. CH 1 to CH 2 Signal Delay Match 4-10
14. CH 1 to CH 4 Signal Delay Match 4-10
15. CH 3 to CH 4 Signal Delay Match 4-10
16. CH 1 and CH 2 Vertical Bandwidth 4-10
17. CH 3 and CH 4 Vertical Bandwidth 4-11
18. SCOPE BW (Bandwidth Limit)
Accuracy 4-11
19. Common-mode Rejection Ratio 4-11
20. Channel Isolation 4-11
21. AC-Coupled Lower -3 dB Point 4-12
22. Vertical ALT and CHOP Modes 4-12
23. BEAM FIND Functional Check 4-13
24. A and B Trace Separation 4-13

Triggering

1. 500 Hz Trigger Sensitivity 4-14
2. 500 kHz Trigger Sensitivity 4-15
3. 25 MHz Trigger Sensitivity 4-15
4. 150 MHz Trigger Sensitivity 4-15
5. Single Sweep Mode 4-16
6. Trigger LEVEL Control Range 4-16
7. TV Field Trigger Sensitivity 4-16

8. TV Line Trigger Sensitivity 4-17
9. Line Trigger Functional Check 4-17

Horizontal

1. A and B Sweep Length 4-18
2. Horizontal POSITION Range 4-18
3. VAR SEC/DIV Range 4-18
4. Magnifier Registration 4-19
5. A and B Timing Accuracy
and Linearity 4-19
6. A and B Magnified Timing
Accuracy and Linearity 4-19
7. Delay Time Jitter 4-21
8. Delay Time Accuracy 4-21
9. Delay Time Position Range 4-21
10. X-Axis Gain Accuracy 4-22
11. X-Y Phase Difference 4-22
12. X-Axis Bandwidth 4-22

Measurement Cursors

1. ← SEC → and ← 1/SEC → Cursor
Accuracy 4-23
2. ← PHASE → Cursor Accuracy 4-23
3. ← VOLTS → Cursor Accuracy 4-24
4. ↗ VOLTS → Cursor Accuracy 4-24
5. Tracking Cursors Position Accuracy ... 4-24

CH1/CH2 Voltmeter

1. DC Volts Accuracy 4-25
2. DC Volts Normal Mode
Rejection Ratio 4-25
3. + Peak, - Peak, Peak-Peak
Volts Accuracy 4-26
4. 25 MHz + Peak, -Peak, and
Peak-to-Peak Volts Accuracy 4-26
5. 100 MHz + Peak, -Peak, and
Peak-to-Peak Volts Accuracy 4-26
6. Gated Volts Accuracy 4-27

Counter/Timer

1. Period 4-28
2. Width 4-28
3. Rise Time Accuracy 4-29

External Z-Axis and Probe Adjust and Auto Setup Functions

1. Check External Z-Axis Input 4-30
2. PROBE ADJUST Output 4-30
3. AUTO SETUP Functional Check 4-30
4. Run MAKE FACTORY SETTINGS
Routine 4-30

DISPLAY

Equipment Required (see Table 4-1)

Time-mark generator
50 Ω BNC termination

50 Ω BNC coaxial cable

1. TRACE ROTATION

a. Set:

READOUT (Intensity)	For a viewable readout
A INTEN	For a viewable trace
Vertical MODE	CH 1
CH 1 VOLTS/DIV	0.1 V
CH 1 COUPLING	AC
A/B SELECT	A Trigger
Trigger MODE	AUTO LEVEL
Trigger SOURCE	VERT
Trigger CPLG	DC
Trigger SLOPE	 (positive-going)
Trigger HOLDOFF	Min
Trigger LEVEL	12 o'clock
Horizontal MODE	A
Horizontal POSITION	12 o'clock
A SEC/DIV	2 μ s
Measurements	All off (press CLEAR DISPLAY three times)
FOCUS	For best defined display
SCOPE BW	Off

b. Position trace vertically to the center graticule line.

c. CHECK—trace rotation control range is adequate to align trace with center graticule line using a small straight-bladed alignment tool.

d. ADJUST—trace parallel to center horizontal graticule line.

2. Geometry

a. Connect time-mark generator (TG 501) to CH 1 via a 50 Ω BNC coaxial cable and a 50 Ω BNC termination.

b. Set generator for 0.2 μ s time markers.

c. Position the bottom of the CH 1 signal below the bottom graticule line. It may be necessary to increase the A intensity in order to see the time markers.

d. CHECK—deviation of any vertical line within the center eight horizontal divisions does not exceed 0.1 division (half a minor division).

e. Set CH 1 COUPLING to GND.

f. Position trace slowly from the bottom graticule line to the top graticule line while making the following check.

g. CHECK—bowing or tilt of baseline trace doesn't exceed 0.1 division (half a minor division) within the eight vertical divisions.

h. Disconnect test signal from the 2247A.

VERTICAL

Equipment Required (see Table 4-1)

Leveled sine-wave generator	50 Ω precision BNC coaxial cable
Calibration generator	50 Ω termination
Function generator	Dual-input coupler
50 Ω BNC coaxial cable	

1. Input COUPLING Functional Check

a. Set:

READOUT (Intensity)	For a viewable readout
A INTEN	For a viewable trace
Vertical MODE	CH 1 and CH 2
CH 1 and CH 2 VOLTS/DIV	1 V
CH 1 and CH 2 Input COUPLING	DC
A/B SELECT	A Trigger
Trigger MODE	AUTO LEVEL
Trigger SOURCE	VERT
Trigger CPLG	DC
Trigger SLOPE	↗ (positive-going)
Trigger LEVEL	12 o'clock
Trigger HOLDOFF	Min
Horizontal POSITION	12 o'clock
Horizontal MODE	A
SEC/DIV	0.5 ms
FOCUS	For best defined display
Measurements	All off (press CLEAR DISPLAY three times)
SCOPE BW	Off
CH 2 INVERT	Off

- b. Set Vertical MODE to CH 1 (CH 2 off).
- c. Connect function generator (FG 502) sine-wave output to the CH 1 input via a 50 Ω BNC coaxial cable and a 50 Ω BNC termination.

- d. Set function generator output for 1 kHz sine-wave signal of five divisions peak-to-peak with maximum positive dc offset.
- e. Position the bottom of the signal to the center horizontal graticule line.
- f. Set CH 1 Input COUPLING to AC.
- g. CHECK—display is roughly centered about the center horizontal graticule line.
- h. Move the test signal to the CH 2 input.
- i. Set CH 2 Vertical MODE to on (CH 1 off).
- j. Repeat the procedure for CH 2.
- k. Disconnect the test signal from the 2247A.

2. CH 1 and CH 2 VOLTS/DIV Trace Shift

a. Set:

CH 1 and CH 2 Vertical MODE	On
CH 1 and CH 2 VOLTS/DIV	2 mV
CH 1 and CH 2 Input COUPLING	GND

- b. Set Vertical MODE to CH 1 (CH 2 off).
- c. Position trace to center horizontal graticule line.
- d. Switch CH 1 VOLTS/DIV through all positions from 2 mV to 5 V.
- e. CHECK—trace shift does not exceed 0.2 division between steps.
- f. Set Vertical MODE to CH 2 (CH 1 off).

- g. Position CH 2 trace to the center horizontal graticule line.
- h. Switch CH 2 VOLTS/DIV through all positions from 2 mV to 5 V.
- i. CHECK—trace shift does not exceed 0.2 division between steps.

3. CH 3 and CH 4 VOLTS/DIV Trace Shift

- a. Set Vertical MODE to CH 3 (CH 2 off).
- b. Position trace to the center horizontal graticule line.
- c. Switch CH 3 VOLTS/DIV between 0.1 V and 0.5 V.
- d. CHECK—trace shift does not exceed one division.
- e. Set Vertical MODE to CH 4 (CH 3 off).
- f. Position trace to the center horizontal graticule line.
- g. Switch CH 4 VOLTS/DIV between 0.1 V and 0.5 V.
- h. CHECK—trace shift does not exceed one division.

4. CH 1 and CH 2 VAR VOLTS/DIV Trace Shift

- a. Set:

Vertical MODE	CH 1 (CH 4 off)
CH 1 VOLTS/DIV	2 mV
- b. Position trace to center graticule line.
- c. Set CH 1 VAR VOLTS/DIV fully ccw.
- d. CHECK—trace shift does not exceed one division.
- e. Set:

CH 1 VAR VOLTS/DIV	Detent (calibrated)
Vertical MODE	CH 2 (CH 1 off)
CH 2 VOLTS/DIV	2 mV
- f. Position trace to center graticule line.
- g. Set CH 2 VAR VOLTS/DIV fully ccw.
- h. CHECK—trace shift does not exceed one division.
- i. Set CH 2 VAR VOLTS/DIV to detent (calibrated) position.

5. CH 1 and CH 2 Input COUPLING Trace Shift

- a. Position trace to center graticule line.
- b. Set CH 2 Input COUPLING to DC.
- c. CHECK—trace shift does not exceed 0.25 division.
- d. Set:

Vertical MODE	CH 1 (CH 2 off)
CH 1 Input COUPLING	GND
- e. Position trace to center graticule line.
- f. Set CH 1 Input COUPLING to DC.
- g. CHECK—trace shift does not exceed 0.25 division.

6. CH 2 INVERT Trace Shift

- a. Set:

Vertical MODE	CH 2 (CH 1 off)
CH 2 Input COUPLING	GND
- b. Position trace to center horizontal graticule line.
- c. Set CH 2 INVERT On.
- d. CHECK—trace shift does not exceed one division.
- e. Set:

CH 2 INVERT	Off
CH 2 COUPLING	DC

7. CH 1 and CH 2 VAR VOLTS/DIV Range

- a. Set Vertical MODE to CH 1 (CH 2 off).
- b. Position CH 1 trace to the center horizontal graticule line.
- c. Set:

CH 1 VOLTS/DIV	10 mV
CH 1 VAR VOLTS/DIV	Fully ccw
- d. Connect calibration generator (PG 506) Std Ampl output to the CH 1 input via 50 Ω precision BNC coaxial cable. Set generator Std Ampl output to 50 mV.
- e. CHECK—the signal amplitude is two divisions or less.

- f. Set:
- | | |
|--------------------|------------------------|
| CH 1 VAR VOLTS/DIV | Detent
(calibrated) |
| Vertical MODE | CH 2 (CH 1 off) |
| CH 2 VOLTS/DIV | 10 mV |
- g. Position CH 2 trace to the center horizontal graticule line.
- h. Move the test signal to the CH 2 input.
- i. Set CH 2 VAR VOLTS/DIV fully ccw.
- j. Repeat the CHECK procedure for CH 2.
- k. Set CH 2 VAR VOLTS/DIV to detent (calibrated) position.

8. Low-Frequency Linearity Check

- a. Set:
- | | |
|----------------|-----------------|
| Vertical MODE | CH 1 (CH 2 off) |
| CH 1 VOLTS/DIV | 10 mV |
| SCOPE BW | On |
- b. Set calibration generator to Std Ampl output, 20 mV.
- c. Move the test signal to the CH 1 input.
- d. Position the top of the signal to the top graticule line.
- e. CHECK—the signal amplitude is between 1.9 and 2.1 divisions.
- f. Set bottom of the signal to bottom graticule line.
- g. CHECK—the signal amplitude is between 1.9 and 2.1 divisions.
- h. Repeat the procedure for CH 2.

9. CH 1 and CH 2 Vertical Deflection Accuracy

- a. Set CH 2 VOLTS/DIV to 2 mV.
- b. Set calibration generator to Std Ampl output, 10 mV.
- c. Position the trace two graticule lines below the center horizontal graticule line.

- d. CHECK—all positions of the VOLTS/DIV settings for correct signal-to-graticule accuracy, using the settings in Table 4-2 for the checks.
- e. Set calibration generator to Std Ampl output, 10 mV.
- f. Move the test signal to the CH 1 input.
- g. Set:
- | | |
|----------------|-----------------|
| Vertical MODE | CH 1 (CH 2 off) |
| CH 1 VOLTS/DIV | 2 mV |
- h. Position the trace two graticule lines below the center horizontal graticule line.
- i. Repeat CHECK procedure for CH 1.

Table 4-2 Signal-to-Graticule Accuracy		
VOLTS/DIV Setting	Std Ampl Setting	Deflection Accy (in divisions)
2 mV	10 mV	4.90 to 5.10
5 mV	20 mV	3.92 to 4.08
10 mV	50 mV	4.90 to 5.10
20 mV	100 mV	4.90 to 5.10
50 mV	200 mV	3.92 to 4.08
0.1 V	500 mV	4.90 to 5.10
0.2 V	1 V	4.90 to 5.10
0.5 V	2 V	3.92 to 4.08
1 V	5 V	4.90 to 5.10
2 V	10 V	4.90 to 5.10
5 V	20 V	3.92 to 4.08

10. CH 3 and CH 4 Vertical Deflection Accuracy

- a. Set:
- | | |
|----------------|-----------------|
| Vertical MODE | CH 3 (CH 1 off) |
| CH 3 VOLTS/DIV | 0.1 V |
- b. Position the trace two graticule lines below the center horizontal graticule line.

- c. Move the test signal to the CH 3 input.
- d. Set the calibration generator to Std Ampl output, 0.5 V.
- e. CHECK—the signal amplitude is between 4.90 and 5.10 divisions.
- f. Move the test signal to the CH 4 input.
- g. Set:

Vertical MODE	CH 4 (CH 3 off)
CH 4 VOLTS/DIV	0.1 V

- h. Position the trace two graticule lines below the center horizontal graticule line.
- i. Repeat CHECK for CH 4.
- j. Set CH 4 VOLTS/DIV to 0.5 V.
- k. Set calibration generator to Std Ampl output, 2 V.
- l. CHECK—the signal amplitude is between 3.92 and 4.08 divisions.

- m. Set:

Vertical MODE	CH 3 (CH 4 off)
CH 3 VOLTS/DIV	0.5 V

- n. Move the test signal to the CH 3 input.
- o. Repeat CHECK for CH 3.
- p. Disconnect the test setup from the 2247A.

11. ADD Mode and CH 2 INVERT Deflection Accuracy

- a. Set:

Vertical MODE	ADD (all others off)
CH 1 and CH 2 VOLTS/DIV	0.1 V
CH 1 and CH 2 Input COUPLING	DC

- b. Connect calibration generator Std Ampl output to the CH 1 and CH 2 inputs via 50 Ω precision BNC coaxial cable and a BNC dual-input coupler.
- c. Set the calibration generator to Std Ampl output, 0.2 V.

- d. Position the ADD signal to the center of the crt graticule with the CH 1 and CH 2 POSITION controls.
- e. CHECK—that the ADD signal amplitude is between 3.92 and 4.08 divisions.
- f. Set CH 2 INVERT On.
- g. CHECK—the ADD signal amplitude is 0.08 division (less than half a minor graticule division) or less excluding trace width (sweep will free run).
- h. Disconnect the test setup from the 2247A.

12. Vertical POSITION Range (all channels)

- a. Set:

A SEC/DIV	0.1 ms
Vertical MODE	CH 1 (ADD off)
CH 1 VOLTS/DIV	1 V
CH 2 INVERT	Off
SCOPE BW	Off
CH 1 and CH 2 Input COUPLING	AC

- b. Connect leveled sine-wave generator (SG 503) output to the CH 1 and CH 2 inputs via a 50 Ω BNC coaxial cable, a 50 Ω BNC termination, and a BNC dual-input coupler.
- c. Position trace to center horizontal graticule line.
- d. Set leveled sine-wave generator output for two-division signal at 50 kHz.
- e. Set:

CH 1 VOLTS/DIV	0.1 V
CH 1 POSITION	Fully cw

- f. CHECK—that the bottom of the waveform is at least one division above the center horizontal graticule line.
- g. Set CH 1 POSITION fully ccw.
- h. CHECK—that the top of the waveform is at least one division below the center horizontal graticule line.

- i. Set:

CH 1 POSITION	12 o'clock
Vertical MODE	CH 2 (CH 1 off)
CH 2 POSITION	Fully cw

Performance Check Procedure – 2247A Service

- j. CHECK – that the bottom of the waveform is at least one division above the center horizontal graticule line.
- k. Set CH 2 POSITION fully ccw.
- l. CHECK – that the top of the waveform is at least one division below the center horizontal graticule line.
- m. Set CH 2 POSITION to 12 o'clock.
- n. Move the BNC dual-input coupler from the CH 1 and CH 2 inputs to the CH 3 and CH 4 inputs.
- o. Set:

Vertical MODE	CH 3 (CH 2 off)
CH 3 and CH 4	
VOLTS/DIV	0.1 V
CH 3 POSITION	Fully cw
- p. CHECK – that the bottom of the waveform is at least one division above the center graticule line.
- q. Set CH 3 POSITION fully ccw.
- r. CHECK – that the top of the waveform is at least one division below the center graticule line.
- s. Set:

CH 3 POSITION	12 o'clock
Vertical MODE	CH 4 (CH 3 off)
- t. Repeat the procedure for CH 4.
- u. Set CH 4 POSITION to 12 o'clock.
- v. Disconnect the test setup from the 2247A.

13. CH 1 to CH 2 Signal Delay Match

- a. Set:

Vertical MODE	CH 1 and CH 2 (CH 4 off)
CH 1 and CH 2	
Input COUPLING	DC
CH 1 and CH 2	
VOLTS/DIV	0.1 V
SEC/DIV	20 ns
Trigger SOURCE	CH 3
- b. Superimpose the CH 1 and CH 2 traces at the 100% graticule marking.

- c. Connect calibration generator (PG 506) Fast Rise, rising-edge signal to the CH 1 and CH 2 inputs via a 50 Ω precision BNC coaxial cable, a 50 Ω BNC termination, and a BNC dual-input coupler.
- d. Connect calibration generator Trig Out signal to the CH 3 input via a 50 Ω BNC coaxial cable and a 50 Ω BNC termination.
- e. Set the calibration generator to Fast Rise and adjust Pulse Amplitude for five divisions of signal amplitude at 1 MHz.
- f. Position the rising edges of the superimposed waveforms horizontally to the center vertical graticule line.

NOTE

It may be necessary to readjust the trigger level to display the rising-edge signal in the Delay Match steps. This can be done most easily by pressing the upper Trigger MODE button to cause the trigger level to be automatically readjusted.

- g. Set X10 MAG On (for 2 ns/div sweep speed).
- h. CHECK – that the leading edges of the two waveforms have less than 0.1 horizontal division separation at the center graticule line excluding trace width.

14. CH 1 to CH 4 Signal Delay Match

- a. Set Vertical MODE to CH 1 and CH 4 (CH 2 off).
- b. Move the CH 2 signal to the CH 4 input connector.
- c. Superimpose the CH 4 waveform on the CH 1 waveform.
- d. CHECK – that the leading edges of the two waveforms have less than 0.1 horizontal division separation at the center graticule line excluding trace width.

15. CH 3 to CH 4 Signal Delay Match

- a. Set:

Vertical MODE	CH 3 and CH 4 (CH 1 off)
Trigger SOURCE	CH 2

- b. Move the CH 3 signal to the CH 2 input and the CH 1 trigger signal to the CH 3 input.
- c. Superimpose CH 3 and CH 4 waveforms at the center graticule line.
- d. CHECK—that the leading edges of the two waveforms have less than 0.1 horizontal division separation at the center graticule line.
- e. Disconnect the test setup.

16. CH 1 and CH 2 Vertical Bandwidth

- a. Set:

X10 MAG	Off
Vertical MODE	CH 1 (CH 3 and CH 4 off)
SEC/DIV	0.1 ms
CH 1 VOLTS/DIV	5 mV
CH 1 and CH 2 Input COUPLING	DC
Trigger SOURCE	VERT
Horizontal POSITION	12 o'clock

- b. Connect leveled sine-wave generator (SG 503) output to the CH 1 input via a 50 Ω precision BNC coaxial cable and a 50 Ω BNC termination.
- c. Set the leveled sine-wave generator output for a six-division signal amplitude at 50 kHz.
- d. Set the generator Frequency Range and Frequency Variable controls for a 90 MHz output signal.
- e. CHECK—the displayed signal amplitude is 4.2 divisions or more as the frequency is increased to 100 MHz.
- f. Repeat the frequency setup and CHECK procedure for VOLTS/DIV settings of 50 mV and 0.5 V.
- g. Move the test signal to the CH 2 input.
- h. Set:

Vertical MODE	CH 2 (CH 1 off)
CH 2 VOLTS/DIV	5 mV
- i. Repeat the complete Bandwidth check procedure for Channel 2.

17. CH 3 and CH 4 Vertical Bandwidth

- a. Set:

Vertical MODE	CH 3 (CH 2 off)
CH 3 and CH 4 VOLTS/DIV	0.1 V

- b. Connect leveled sine-wave generator (SG 503) output to the CH 3 input via a 50 Ω precision BNC coaxial cable and a 50 Ω BNC termination.
- c. Set the generator output for a six-division signal display at 50 kHz.
- d. Set the generator Frequency Range and Frequency Variable controls for a 90 MHz output frequency.
- e. CHECK—that the signal display amplitude is 4.2 divisions or more as the frequency is increased to 100 MHz.
- f. Repeat the procedure for 0.5 VOLTS/DIV setting.
- g. Move the test signal to the CH 4 input.
- h. Set Vertical MODE to CH 4
- i. Repeat the procedure for CH 4.

18. SCOPE BW (Bandwidth Limit) Accuracy

- a. Set:

Vertical MODE	CH 1 (CH 4 off)
CH 1 VOLTS/DIV	10 mV
SCOPE BW	On

- b. Move test signal from the CH 4 input to the CH 1 input.
- c. Set leveled sine-wave generator (SG 503) output for a six-division signal amplitude at 50 kHz.
- d. Increase the leveled sine-wave generator output frequency, using the Frequency Range and Frequency Variable controls, until a signal display amplitude of 4.2 divisions is obtained.
- e. CHECK—that the sine-wave generator output frequency is between 17 MHz and 23 MHz.
- f. Disconnect the test setup.

19. Common-Mode Rejection Ratio

- a. Connect leveled sine-wave generator (SG 503) output to the CH 1 and CH 2 input connectors via a 50 Ω precision BNC coaxial cable, a 50 Ω BNC termination, and a BNC dual-input coupler.
- b. Set the leveled sine-wave generator output for an eight-division signal-display amplitude at 50 kHz.
- c. Set:

Vertical MODE	ADD (CH 1 off)
CH 2 VOLTS/DIV	10 mV
CH 2 INVERT	On
SCOPE BW	Off
- d. Adjust CH 1 or CH 2 VAR VOLTS/DIV for smallest signal amplitude (as needed).
- e. Set the leveled sine-wave output frequency to 50 MHz.
- f. Set the Vertical MODE to CH 1 (ADD off).
- g. Set the leveled sine-wave output amplitude for an eight-division display.
- h. Set the Vertical MODE to ADD (CH 1 off).
- i. CHECK—the signal is less than 0.8 division in amplitude.
- j. Disconnect the test setup.

20. Channel Isolation

- a. Set:

Vertical MODE	CH 1 and CH 2 (ADD off)
CH 2 INVERT	Off
CH 1, CH 2, CH 3, and CH 4 VOLTS/DIV	0.1 V
Trigger SOURCE	CH 1
- b. Connect the leveled sine-wave generator (SG 503) output to the CH 1 input via a 50 Ω precision BNC coaxial cable and a 50 Ω BNC termination.
- c. Set the leveled sine-wave generator (SG 503) output for a five-division signal display amplitude at 100 MHz.

- d. Set CH 2, CH 3, and CH 4 Vertical MODE On (CH 1 off).
- e. CHECK—display amplitude is 0.1 division or less, excluding trace width, on the CH 2, CH 3, and CH 4 traces.
- f. Move sine-wave generator signal to the CH 2 input.
- g. Set:

Vertical MODE	CH 1, CH 3, and CH 4 (CH 2 off)
Trigger SOURCE	CH 2
- h. CHECK—display amplitude is 0.1 division or less, excluding trace width, on the CH 1, CH 3, and CH 4 traces.
- i. Move sine-wave generator signal to the CH 3 input.
- j. Set:

Vertical MODE	CH 1, CH 2, and CH 4 (CH 3 off)
Trigger SOURCE	CH 3
- k. CHECK—display amplitude is 0.1 division or less, excluding trace width, on the CH 1, CH 2, and CH 4 traces.
- l. Move sine-wave generator signal to the CH 4 input.
- m. Set:

Vertical MODE	CH 1, CH 2, and CH 3 (CH 4 off)
Trigger SOURCE	CH 4
- n. CHECK—display amplitude is 0.1 division or less, excluding trace width, on the CH 1, CH 2, and CH 3 traces.
- o. Disconnect the test setup.

21. AC-Coupled Lower -3 dB Point

- a. Set:

A SEC/DIV	10 ms
Vertical MODE	CH 1 (all others off)
Trigger SOURCE	VERT
Trigger MODE	NORM

- b. Connect function generator (FG 502) output to the CH 1 input via a 50 Ω BNC coaxial cable and a 50 Ω BNC termination.
- c. Set the function generator output controls to produce a six-division sine-wave display at 10 Hz (with no dc offset).
- d. Set CH 1 Input COUPLING to AC.
- e. CHECK – display amplitude is 4.2 division or more.
- f. Set Vertical MODE to CH 2 (CH 1 off).
- g. Repeat the procedure for CH 2.
- h. Disconnect the test equipment from the 2247A.

22. Vertical ALT and CHOP Modes

- a. Set:

Vertical MODE	CH 1, CH 2, CH 3, and CH 4 on
CHOP Vertical MODE	Off (ALT mode)
CH 1 and CH 2 VOLTS/DIV	10 mV
CH 3 and CH 4 VOLTS/DIV	0.1 V
CH 1 and CH 2 Input COUPLING	DC
Horizontal MODE	A
SEC/DIV	0.1 ms
Trigger MODE	AUTO LEVEL

- b. Position all traces for two divisions of separation with the CH 1 trace near the top; then in order down the graticule area with the CH 4 trace near the bottom.
- c. Set SEC/DIV to 10 ms.
- d. CHECK – that four traces are sweeping across the screen alternately.

- e. Set CHOP Vertical MODE On.
- f. CHECK – that four traces are sweeping across the screen simultaneously.

23. BEAM FIND Functional Check

- a. Push BEAM FIND in and hold.
- b. CHECK – the signal is visible and compressed fully within the graticule area as the horizontal and vertical position controls are rotated through their ranges.
- c. Release the BEAM FIND button.
- d. Set all Vertical and Horizontal POSITION controls at the 12 o'clock position.

24. A and B Trace Separation

- a. Set:

A SEC/DIV	1 ms
Vertical MODE	CH 1 (others off)
Horizontal MODE	ALT
B SEC/DIV	0.5 ms
A/B SELECT	B
B Trigger MODE	RUNS AFTER
TRACE SEP	Fully cw

- b. Position the CH 1 trace below the center horizontal graticule line to display the separated B trace.
- c. CHECK – for at least four divisions of upward trace separation between the B trace and the A trace.
- d. Set TRACE SEP fully ccw.
- e. Position the CH 1 trace above the center horizontal graticule line to display the separated B trace.
- f. CHECK – for at least four divisions downward trace separation of the B trace from the A trace.

TRIGGERING

Equipment Required (see Table 4-1)

Leveled sine-wave generator	Function generator
50 Ω BNC coaxial cable	10X BNC attenuator
2X BNC attenuator	50 Ω BNC termination
Dual-input coupler	TV signal generator

1. 500 Hz Trigger Sensitivity

a. Set:

READOUT (Intensity)	For a viewable readout
A INTEN	For a viewable trace
Vertical MODE	CH 1
CH 1 and CH 2 Input COUPLING	DC
CH 1 VOLTS/DIV	0.1 V
SCOPE BW	On
Horizontal MODE	A
A SEC/DIV	1 ms
A/B SELECT	A Trigger
Trigger MODE	AUTO LEVEL
Trigger SOURCE	VERT
Trigger CPLG	AC
Trigger SLOPE	↗ (positive-going)
Trigger HOLDOFF	Min
FOCUS	For best defined display
Measurements	All off (press CLEAR DISPLAY three times)
Horizontal POSITION	12 o'clock

- b. Connect function generator (FG 502) output to the CH 1 input via a 50 Ω BNC coaxial cable, and a 50 Ω BNC termination.
- c. Set function generator (FG 502) output to produce a 7.0 division sine-wave display at 500 Hz.
- d. Add a 10X and a 2X BNC attenuator before the 50 Ω BNC termination (for a 0.35 division display).

NOTE

The Trigger LEVEL control may be used to obtain a stable display.

- e. CHECK—that the display is stably triggered with DC, HF REJ, and AC Trigger CPLG; and that the display will not trigger on NOISE REJ or LF REJ Trigger CPLG.

f. Set:

A Trigger CPLG	DC
Horizontal MODE	B
A/B SELECT	B Trigger
B Trigger MODE	NORM
B Trigger SOURCE	VERT
B Trigger SLOPE	↗ (positive-going)
B SEC/DIV	0.5 ms
DELAY Time	?0.000 (minimum delay time)
B INTEN	For viewable display

NOTE

It may be necessary to adjust the Trigger LEVEL control to obtain a display.

- g. CHECK—that using the Trigger LEVEL control, the display can be stably triggered in DC, HF REJ, and AC Trigger CPLG; and that the display cannot be triggered in NOISE REJ or LF REJ Trigger CPLG.
- h. Disconnect the test setup from the CH 1 input.

2. 500 kHz Trigger Sensitivity

- a. Set:
- | | |
|-----------------|-----------|
| SCOPE BW | Off |
| Horizontal MODE | A |
| A/B SELECT | A Trigger |
| A SEC/DIV | 2 μ s |
- b. Connect leveled sine-wave generator (SG 503) output to the CH 1 input via a 50 Ω BNC coaxial cable and a 50 Ω BNC termination.
- c. Set leveled sine-wave generator output to produce a 7.0 division sine-wave display amplitude at 500 kHz.
- d. Add a 10X and a 2X BNC attenuator before the 50 Ω BNC termination (for a 0.35 division display amplitude).
- e. CHECK—that the display cannot be triggered in either HF REJ or NOISE REJ CPLG.
- f. Set:
- | | |
|-----------------|-----------|
| Horizontal MODE | B |
| A/B SELECT | B Trigger |
| B SEC/DIV | 1 μ s |
- g. CHECK—that the display cannot be triggered in HF REJ or NOISE REJ CPLG by adjusting the Trigger LEVEL control.

3. 25 MHz Trigger Sensitivity

- a. Set:
- | | |
|-----------------|-----------|
| Horizontal MODE | A |
| A/B SELECT | A Trigger |
| A Trigger CPLG | DC |
| A SEC/DIV | 50 ns |
- b. Remove the 10X and 2X BNC attenuators from the signal path.
- c. Set leveled sine-wave generator output to produce a 7.0 division display amplitude at 25 MHz.
- d. Add a 10X and a 2X BNC attenuator before the 50 Ω BNC termination.
- e. CHECK—that the display is stably triggered in DC, LF REJ, and AC Trigger CPLG; the display is not triggered in NOISE REJ and HF REJ Trigger CPLG settings.

- f. Set:
- | | |
|-----------------|-----------|
| A Trigger CPLG | DC |
| Horizontal MODE | B |
| A/B SELECT | B Trigger |
| B SEC/DIV | 20 ns |
- g. CHECK—that using the Trigger LEVEL control, the display can be stably triggered in DC, LF REJ, and AC Trigger CPLG; the display cannot be triggered in NOISE REJ and HF REJ Trigger CPLG settings.
- h. Set leveled sine-wave generator (SG 503) to produce a 1.4 division display at 25 MHz.
- i. CHECK—that the display can be stably triggered with NOISE REJ Trigger CPLG but does not trigger with HF REJ CPLG.
- j. Set:
- | | |
|-----------------|-----------|
| Horizontal MODE | A |
| A/B SELECT | A Trigger |
- k. CHECK—that the display is stably triggered with NOISE REJ Trigger CPLG but does not trigger with HF REJ CPLG. (The Trigger LEVEL control may be adjusted to improve display stability in NOISE REJ CPLG.)

4. 150 MHz Trigger Sensitivity

- a. Set Trigger CPLG to DC.
- b. Set leveled sine-wave generator to produce a 1.0 division display at 150 MHz.
- c. CHECK—that the display is stably triggered in DC, LF REJ, and AC Trigger CPLG.
- d. Set:
- | | |
|-----------------|-----------|
| Horizontal MODE | B |
| A/B SELECT | B Trigger |
- e. CHECK—that using the Trigger LEVEL control the display can be stably triggered in DC, LF REJ, and AC Trigger CPLG.
- f. Set:
- | | |
|----------------------|-----------------|
| Horizontal MODE | A |
| Vertical MODE | CH 2 (CH 1 off) |
| CH 2, CH 3, and CH 4 | |
| VOLTS/DIV | 0.1 V |
| A/B SELECT | A Trigger |
| A Trigger CPLG | DC |

Performance Check Procedure—2247A Service

- g. Move test signal from CH 1 to the CH 2 input.
- h. Set leveled sine-wave generator output to produce a 1.0 division display amplitude at 150 MHz.
- i. CHECK—that a stable display can be obtained. (The Trigger LEVEL control may be adjusted to improve the display stability.)
- j. Repeat the procedure for CH 3 and CH 4 (turn on the appropriate Vertical MODE and move the test signal as required).
- k. Move test signal to the CH 1 input.
- l. Set Vertical MODE to CH 1 (others off).
- m. Remove the 2X BNC attenuator from the test signal path.
- n. Set leveled sine-wave generator output for a 2.2-division display amplitude at 100 MHz.
- o. CHECK—that the display is stably triggered with NOISE REJ Trigger CPLG but is not triggered with HF REJ Trigger CPLG.
- p. Set leveled sine-wave generator output for a 0.5-division display amplitude at 100 MHz.
- q. CHECK—that the display is not triggered in NOISE REJ Trigger CPLG.
- r. Set:
- | | |
|-----------------|-----------|
| A Trigger CPLG | DC |
| Horizontal MODE | B |
| A/B SELECT | B Trigger |
- s. Repeat 100 MHz NOISE REJ Trigger CPLG procedure for the B Trigger.
- c. Set leveled sine-wave generator output to produce a 7.0 division display amplitude at 50 kHz.
- d. Add a 10X and a 2X BNC attenuator before the 50 Ω BNC termination. (Display should stably trigger with AUTO LEVEL finding the correct trigger level setting.)
- e. Set:
- | | |
|---------------------|---------|
| A Trigger MODE | NORM |
| CH 1 Input COUPLING | GND |
| Trigger MODE | SGL SEQ |
- f. CHECK—that the Trigger READY LED turns on and remains on.
- g. Set:
- | | |
|---------------------|----------------------|
| A INTEN | 3/4 fully CW |
| CH 1 Input COUPLING | DC (see CHECK below) |
- h. CHECK—that the TRIG'D LED flashes, and the READY LED turns off after a single sweep and readout display occurs when the Input COUPLING switches to DC.

6. Trigger LEVEL Control Range

- a. Set:
- | | |
|---------------|------------------------------|
| Trigger MODE | AUTO (not AUTO LEVEL) |
| Trigger LEVEL | Fully ccw |
| A INTEN | For a good viewing intensity |
- b. Remove 10X and 2X BNC attenuators from the test signal path.
- c. Increase leveled sine-wave generator output level until a stably triggered display is just obtainable.
- d. Set Trigger LEVEL fully cw.
- e. Set leveled sine-wave generator output for a stable display (if necessary).
- f. Set CH 1 VOLTS/DIV to 1 V.

5. Single Sweep Mode

- a. Set:
- | | |
|-----------------|------------|
| Horizontal MODE | A |
| A SEC/DIV | 10 μ s |
| A/B SELECT | A Trigger |
- b. Remove the 10X BNC attenuator from the test signal path.

g. CHECK—that the CH 1 signal display amplitude is four divisions or more (peak-to-peak). Note that the signal is not triggered.

h. Disconnect the test setup from the 2247A.

7. TV Field Trigger Sensitivity

a. Set:

Vertical MODE	CH 2 (CH 1 off)
CH 2 VOLTS/DIV	1 V
SEC/DIV	0.2 ms
Trigger MODE	TV FIELD
Trigger SLOPE	\neg (negative-going)

b. Connect TV signal generator (TSG-100) video output to the CH 2 input via a 50 Ω BNC cable.

c. Set CH 2 VAR VOLTS/DIV control for a 0.5 division composite sync signal.

d. CHECK—that a stable display is obtained.

e. Set:

CH 2 INVERT	On
Trigger SLOPE	\neg (positive-going)

f. CHECK—that a stable display is obtained.

g. Set:

CH 2 INVERT	Off
Trigger SLOPE	\neg (negative-going)

8. TV Line Trigger Sensitivity

a. Set:

A SEC/DIV	2 ms
Horizontal MODE	B
B SEC/DIV	20 μ s
A/B SELECT	B
B Trigger MODE	TV LINE

b. CHECK—that a stable display is obtained for various portions of the TV field as the \leftarrow OR DELAY control is rotated.

c. Set CH 2 VAR VOLTS/DIV to the detent position (calibrated).

d. Disconnect the TV signal generator from the 2247A.

9. Line Trigger Functional Check

a. Set:

CH 2 VOLTS/DIV	0.1 V (without a 10X probe attached)
CH 2 Input COUPLING	DC
Horizontal MODE	A
A SEC/DIV	5 ms
Trigger MODE	AUTO LEVEL
Trigger SOURCE	LINE
Trigger CPLG	DC

b. Connect a 10X probe to the CH 2 input connector.

c. Attach the probe tip to a length of wire at least four inches long. Hold the wire near the middle portion of the instrument power cord.

d. CHECK—that the display can be triggered in both \neg (positive-going) and \neg (negative-going) slopes.

e. Disconnect the test setup.

HORIZONTAL

Equipment Required (see Table 4-1)

Time-mark generator
50 Ω BNC termination

50 Ω BNC coaxial cable

1. A and B Sweep Length

- a. Set:
- | | |
|---------------------|--|
| READOUT (Intensity) | For a viewable readout |
| A INTEN | For a viewable trace |
| Vertical MODE | CH 1 |
| CH 1 and CH 2 | |
| Input COUPLING | DC |
| CH 1 VOLTS/DIV | 0.5 V |
| Horizontal MODE | A |
| A SEC/DIV | 2 ms |
| Horizontal POSITION | 12 o'clock |
| A/B SELECT | A Trigger |
| Trigger MODE | AUTO LEVEL |
| Trigger SOURCE | VERT |
| Trigger CPLG | AC |
| Trigger SLOPE |  (positive-going) |
| Trigger HOLDOFF | Min |
| Trigger LEVEL | 12 o'clock |
| Measurements | All off (press CLEAR DISPLAY three times) |
| FOCUS | For best defined display |

- b. Connect time-mark generator (TG 501) to the CH 1 input via a 50 Ω BNC coaxial cable and a 50 Ω BNC termination.
- c. Set generator for 2 ms time markers.
- d. CHECK – sweep length of the A trace is greater than 10 divisions.

e. Set:

Horizontal MODE	B
B SEC/DIV	1 ms
A/B SELECT	B Trigger
Trigger MODE	RUNS AFTER
← OR DELAY Control	ccw to the lowest DELAY readout value
B INTEN	For a visible display

- f. CHECK – the Delay Time readout is ?0.000 ms, and the B Sweep length is greater than 10 divisions.

2. Horizontal POSITION Range

a. Set:

Horizontal MODE	A
Horizontal POSITION	Fully cw

- b. CHECK – that the start of trace positions past the center vertical graticule line.
- c. Set Horizontal POSITION fully ccw.
- d. CHECK – that the 11th time marker is positioned to the left of the center vertical graticule line.

3. VAR SEC/DIV Range

a. Set:

SEC/DIV	1 ms
SEC/DIV VAR	Fully ccw
Horizontal POSITION	12 o'clock

- b. Set time-mark generator for 5 ms time markers.

- c. CHECK—the time–mark spacing is equal to or less than two divisions.
- d. Set SEC/DIV VAR fully cw (calibrated detent).

4. Magnifier Registration

- a. Set X10 MAG on.
- b. Position the rising edge of a time marker to the center vertical graticule line.
- c. Set X10 MAG off.
- d. CHECK—for less than 0.5 division horizontal trace shift.

5. A and B Timing Accuracy and Linearity

- a. Set A SEC/DIV to 20 ns.
- b. Set time–mark generator for 20 ns time markers.
- c. Position the time marker peaks vertically to the center horizontal graticule line (allows use of the minor division graticule markings as an aid in making the accuracy checks).

NOTE

For the fastest sweep speeds, where the time marker peaks are rounded and not well defined, greater resolution can be achieved by vertically centering the display and using the points where the rising edges of the time markers cross the center horizontal graticule line as a reference.

- d. Position the second time marker to the second vertical graticule line.
- e. CHECK—that the tenth time marker is within 0.16 division (left or right) of the tenth graticule line.
- f. CHECK—that the spacing of time markers over any two–division interval within the center eight divisions does not deviate from the value measured at the center two divisions by more than 0.1 division.
- g. Repeat the procedure for all other SEC/DIV settings. Use the SEC/DIV and Time Mark Generator settings

in the column labeled X1 given in Table 4–3, Settings for Timing Accuracy Checks.

- h. Set SEC/DIV to 20 ns.
- i. Set time–mark generator for 20 ns time markers.
- j. Set:

Horizontal MODE	B
B INTEN	For a viewable display
- k. Repeat the CHECK procedure for all the B SEC/DIV settings.

6. A and B Magnified Timing Accuracy and Linearity

- a. Set time–mark generator for 5 ns time markers.
- b. Set:

Horizontal MODE	A
A SEC/DIV	20 ns
Horizontal MODE	B
B SEC/DIV	20 ns
X10 MAG	On (for 2 ns/div sweep speed)
CH 1 VOLTS/DIV	0.5 V (use 0.2 V for the 5 ns time markers if necessary)
- c. Set the Horizontal POSITION control to 12 o'clock and then align the rising edge of the nearest time marker to the second vertical graticule line (center the display vertically).

NOTE

For the fastest sweep speeds, where the time marker peaks are rounded and not well defined, greater resolution can be achieved by vertically centering the display and using the points where the rising edges of the time markers cross the center horizontal graticule line as a reference.

- d. CHECK—that the rising edge of the fourth displayed time marker crosses the center horizontal graticule line at between 8.27 divisions and 8.73 divisions from the left–most graticule line.

Table 4-3
Settings for Timing Accuracy Checks

SEC/DIV Setting		Time-Mark Setting	
X1	X10 MAG	X1	X10 MAG
20 ns	2 ns	20 ns	5 ns
50 ns	5 ns	50 ns	5 ns
0.1 μs	10 ns	0.1 ns	10 ns
0.2 μs	20 ns	0.2 μs	20 ns
0.5 μs	50 ns	0.5 μs	50 ns
1 μs	0.1 μs	1 μs	0.1 μs
2 μs	0.2 μs	2 μs	0.2 μs
5 μs	0.5 μs	5 μs	0.5 μs
10 μs	1 μs	10 μs	1 μs
20 μs	2 μs	20 μs	2 μs
50 μs	5 μs	50 μs	5 μs
0.1 ms	10 μs	0.1 ms	10 μs
0.2 ms	20 μs	0.2 ms	20 μs
0.5 ms	50 μs	0.5 ms	50 μs
1 ms	0.1 ms	1 ms	0.1 ms
2 ms	0.2 ms	2 ms	0.2 ms
5 ms	0.5 ms	5 ms	0.5 ms
A Sweep only			
10 ms	1 ms	10 ms	1 ms
20 ms	2 ms	20 ms	2 ms
50 ms	5 ms	50 ms	5 ms
0.1 s	10 ms	0.1 s	10 ms
0.2 s	20 ms	0.2 s	20 ms
0.5 s	50 ms	0.5 s	50 ms

e. CHECK—that the spacing of the time markers over any 2.5-division interval within the center eight divisions does not deviate from the value measured at the center 2.5 divisions by more than 0.12 division. Use the fifth vertical graticule line as a starting point for the measurement at the center 2.5 divisions. Exclude the first 1/4 division or 25 ns and any portion of the sweep past the 100th magnified division.

f. Set SEC/DIV to 5 ns.

g. Set the Horizontal POSITION control to 12 o'clock and then align the nearest time marker to the second vertical graticule line.

h. CHECK—that the tenth displayed time marker is within 0.24 division (left or right) of the tenth graticule line.

- i. CHECK—that the spacing of the time markers over any two-division interval within the center eight divisions does not deviate from the value measured at the center two divisions by more than 0.1 division. Exclude the first 1/4 division or 25 ns and any portion of the sweep past the 100th magnified division.
- j. Repeat the timing and linearity checks for all SEC/DIV settings between 10 ns and 0.5 ms. Use the SEC/DIV and Time-Mark Generator X10 MAG settings given in Table 4-3.
- k. Set:

Horizontal MODE	A
SEC/DIV	2 ns (with X10 MAG on)
- l. Set time-mark generator for 5 ns time markers.
- m. Repeat the magnified timing accuracy and linearity checks for the A Sweep at all magnified SEC/DIV settings.

7. Delay Time Jitter

- a. Set:

X10 MAG	Off
A SEC/DIV	1 ms
Horizontal MODE	ALT
SEC/DIV	0.5 μs
- b. Set time-mark generator for 1 ms time markers.
- c. Position the intensified dot to the leading edge of the 10th time marker to display the rising edge on the B Trace (using the ← OR DELAY control). It may be necessary to reduce the A intensity level to observe the intensified dot.
- d. Set:

Horizontal MODE	B
B INTEN	Fully cw (maximum intensity)
- e. CHECK—that the jitter on the leading edge does not exceed one division over a two-second interval. Disregard slow drift.

8. Delay Time Accuracy

- a. Set:

Horizontal MODE	ALT
B SEC/DIV	10 μs
TRACE SEP	Fully ccw (maximum downward position)
CH 1 POSITION	To display both the ALT and the B Delayed Traces
- b. Position the intensified dot to full left position (counterclockwise rotation of the ← OR DELAY control).
- c. Align the leading edge of the time marker displayed on the B trace to the left-most (first) graticule line, using only the Horizontal POSITION control.
- d. CHECK—that the readout is ?0.000 ms.
- e. Position the intensified zone to the second time marker and align the leading edge of the time marker displayed on the B trace to the left-most (first) graticule line, using only the ← OR DELAY control. Using the Readout Accuracy Limits given in Table 4-4, check the delay time accuracy.
- f. Repeat the procedure for the third through tenth time markers.

Table 4-4
Delay Time Accuracy

Time Marker	Readout Accuracy Limits
1st	? 0.000 ms
2nd	0.945 ms to 1.055 ms
3rd	1.940 ms to 2.060 ms
4th	2.935 ms to 3.065 ms
5th	3.930 ms to 4.070 ms
6th	4.925 ms to 5.075 ms
7th	5.920 ms to 6.080 ms
8th	6.915 ms to 7.085 ms
9th	7.910 ms to 8.090 ms
10th	8.905 ms to 9.095 ms

9. Delay Time Position Range

- a. Set time-mark generator for 0.1 ms.
- b. Set:

A SEC/DIV	1 ms
B SEC/DIV	5 μ s
\leftarrow OR DELAY control	ccw to ?0.000
- c. CHECK – that the intensified dot is positioned at or before the second time marker.
- d. Turn the \leftarrow OR DELAY control clockwise until the delay readout stops increasing (largest number).
- e. CHECK – that the intensified dot is positioned at or after the 99th time marker (located at a Delay Time of 9.9 ms).
- f. Disconnect the time-mark generator from the 2247A.

10. X-Axis Gain Accuracy

- a. Set:

Horizontal MODE	X-Y
Vertical MODE	CH 2 (CH 1 off)
CH 1 and CH 2	
VOLTS/DIV	10 mV
CH 1 Input COUPLING	DC
CH 2 Input COUPLING	GND
- b. Connect calibration generator Std Ampl output to the CH 1 input via a 50 Ω precision BNC coaxial cable.
- c. Set calibration generator for Std Ampl output, 50 mV.
- d. CHECK – X-Axis amplitude is between 4.85 and 5.15 horizontal divisions.
- e. Disconnect calibration generator.

11. X-Y Phase Difference

- a. Set:

Horizontal MODE	A
Vertical MODE	CH 1 (CH 2 off)
CH 1 Input COUPLING	DC
- b. Connect leveled sine-wave generator output to the CH 1 input via a 50 Ω BNC coaxial cable and a 50 Ω BNC termination.
- c. Set leveled sine-wave generator output for six divisions of signal display amplitude at 50 kHz.
- d. Set:

Horizontal MODE	X-Y
CH 1 Input COUPLING	GND
- e. Position dot to graticule center.
- f. Set CH 1 Input COUPLING to DC.
- g. CHECK – ellipse opening at the center is 0.3 division or less, measured horizontally.

12. X-Axis Bandwidth

- a. Set Vertical MODE to CH 2 (CH 1 off).
- b. Set leveled sine-wave generator output for six divisions of horizontal display amplitude at 50 kHz.
- c. Set leveled sine-wave output to 3 MHz.
- d. CHECK – X-Axis display is 4.2 horizontal divisions or more.
- e. Disconnect the test equipment from the 2247A.

MEASUREMENT CURSORS

Equipment Required (see Table 4-1)

Time-mark generator
50 Ω BNC coaxial cable

Calibration generator
50 Ω BNC termination

1. \leftarrow SEC \rightarrow and \leftarrow 1/SEC \rightarrow Cursor Accuracy

a. Set:

READOUT (Intensity)	For a viewable readout
A INTEN	For a viewable trace
Vertical MODE	CH 1
CH 1 VOLTS/DIV	0.5 V
CH 1 and CH 2 Input COUPLING	DC
Horizontal MODE	A
A SEC/DIV	1 ms
A/B SELECT	A Trigger
Trigger MODE	AUTO LEVEL
Trigger CPLG	DC
Trigger SOURCE	VERT
Trigger SLOPE	\nearrow (positive-going)
Trigger HOLDOFF	MIN
CH 2 INVERT	Off
SCOPE BW	Off
FOCUS	For best defined display

NOTE

Before performing this check, go to CONFIGURE in the SERVICE MENU and select NO for INITIALIZE TIME CURSORS/ DELAYS?

- Connect time-mark generator (TG 501) output via a 50 Ω BNC coaxial cable and a 50 Ω BNC termination to the CH 1 input.
- Set time-mark generator for 1 ms time markers.
- Position first time marker horizontally to the first vertical graticule line (left-most edge of the graticule).

- Press TIME button to display the TIME menu.
- Press \leftarrow SEC \rightarrow menu button to turn on time cursors.
- Position the reference cursor to the second time marker and the delta cursor to the tenth time marker.
- CHECK—that the readout is 7.940 ms to 8.060 ms.
- Press the TIME button to display the TIME menu.
- Set \leftarrow 1/SEC \rightarrow on.
- Reposition the reference cursor to the second time marker and the delta cursor to the tenth time marker.
- CHECK—that the readout is 124 Hz to 126 Hz.

2. \leftarrow PHASE \rightarrow Cursor Accuracy

- Press the TIME button to display the TIME menu.
- Press \leftarrow PHASE \rightarrow menu selection to display the menu choices.
- Set \leftarrow SET 360 $^{\circ}$ \rightarrow on.
- Position the first time marker to first graticule line. Then position the Reference cursor to the leading edge of the second time marker and the delta cursor to the leading edge of the tenth time marker.
- Set \leftarrow PHASE \rightarrow on.
- Position delta cursor to the leading edge of the sixth time marker.
- CHECK—that the readout is between 177.9 and 182.1 degrees.
- Disconnect time-mark generator.

3. ← VOLTS→ Cursor Accuracy

- a. Set:
- | | |
|----------------|--------|
| CH 1 VOLTS/DIV | 0.1 V |
| SEC/DIV | 0.5 ms |
- b. Select CURSOR VOLTS menu, then select ← VOLTS→.
- c. Connect calibration generator (PG 506) output to the CH 1 input via a 50 Ω precision BNC coaxial cable.
- d. Set calibration generator to Std Ampl 0.5 V.
- e. Position bottom of the signal to the second horizontal graticule line from the bottom.
- f. Position the reference cursor to the bottom of the signal and the delta cursor to the top of the signal (both cursors move with the ← OR DELAY control).
- g. CHECK—that the readout is between 0.495 V and 0.505 V.

4. ↗ VOLTS→ Cursor Accuracy

- a. Select CURSOR VOLTS menu, then select ↗ VOLTS→.
- b. Position the → control to align the delta cursor with the top of the waveform.
- c. CHECK—that the readout is between 0.495 V and 0.505 V and none of the cursors move when the ← OR DELAY control is rotated.

5. Tracking Cursors Position Accuracy

- a. Press CLEAR DISPLAY twice.
- b. Press the CURSOR VOLTS button to display the CURSOR VOLTS menu. Press the (TO AUTO TRACKING MENU) button. Press the TRACK TRIG LVL and TRACK buttons so that those functions are underlined. Press the (MENU OFF) button to clear the menus.
- c. Set Trigger MODE to AUTO (not AUTO LEVEL).
- d. Adjust Trigger LEVEL control to align trigger level cursor with the bottom of the signal.
- e. CHECK—the readout is 0.000 V ± 0.005 V and the GND cursor is aligned with the bottom of the signal.
- f. Set trigger level cursor to align with the top of the signal.
- g. CHECK—the readout is between 0.475 V and 0.525 V.
- h. Press CLEAR DISPLAY.
- j. Disconnect test equipment if ending here.

CH 1/CH 2 VOLTMETER

Equipment Required (see Table 4-1)

Calibration generator	50 Ω BNC coaxial cable
Leveled sine-wave generator	50 Ω BNC termination
Function generator	BNC coupling capacitor

1. DC Volts Accuracy

a. Set:

READOUT (Intensity)	For a viewable readout
A INTEN	For a viewable trace
Vertical MODE	CH 1
CH 1 VOLTS/DIV	50 mV
CH 2 INVERT	Off
SCOPE BW	Off
CH 1 Input COUPLING	GND
Horizontal MODE	A
A SEC/DIV	1 ms
A/B SELECT	A Trigger
Trigger MODE	AUTO LEVEL
Trigger CPLG	DC
Trigger SOURCE	VERT
Trigger SLOPE	↗ (positive-going)
Trigger HOLDOFF	MIN
FOCUS	For best defined display
Horizontal POSITION	12 o'clock

- b. Press the VOLTMETER button and then press DC on the VOLTMETER menu.
- c. CHECK—ground readout is 0.0 mV ±1.2 mV.
- d. Set calibration generator (PG 506) internal Square Wave/DC switch to DC.

NOTE

The PG 506 must be removed from the TM power supply to make the change to dc output from the generator. Turn the power off before removing or inserting any plug-in from the TM power supply

- e. Connect the calibration generator Std Ampl output to the CH 1 input via a 50 Ω precision BNC coaxial cable.
- f. Set calibration generator for Std Ampl output of 50 mV dc.
- g. Set:

CH 1 VOLTS/DIV	10 mV
CH 1 Input COUPLING	DC
- h. CHECK—the readout is between 49.0 mV and 51.0 mV.
- i. Set CH 1 VOLTS/DIV to 0.1 V.
- j. Set calibration generator for Std Ampl output of 0.5 V.
- k. CHECK—the readout is between 0.495 V and 0.505 V.
- l. Set CH 1 VOLTS/DIV to 1 V.
- m. Set calibration generator for Std Ampl output of 5 V.
- n. CHECK—the readout is between 4.95 V and 5.05 V.
- o. Disconnect Std Ampl signal from the CH 1 input.

2. DC Volts Normal Mode Rejection Ratio

- a. Set SEC/DIV to 5 ms.
- b. Connect function generator (FG 502) output to the CH 1 input via a 50 Ω BNC coaxial cable and a BNC coupling capacitor.
- c. Set function generator for a six-division sine-wave display amplitude at 50 Hz (with CH 1 VOLTS/DIV at 1 V).
- d. Set CH 1 VOLTS/DIV to 0.2 V.

- e. CHECK – that the readout is less than ± 0.010 V.
- f. Disconnect the function generator signal from the 2247A.

3. +Peak, -Peak, Peak-to-Peak Volts Accuracy

- a. Set:

Vertical MODE	CH 2 (CH 1 off)
CH 2 VOLTS/DIV	10 mV
CH 2 Input COUPLING	DC
- b. Press the VOLTMETER button and then press +PEAK on the VOLTMETER menu.
- c. Set the calibration generator (PG 506) internal Square Wave/DC Switch for a square-wave output signal.

NOTE

It is necessary to remove the PG 506 from the TM power supply module to set the internal Square Wave/DC switch to square-wave output.

- d. Connect calibration generator Std Ampl output to the CH 2 input via a 50 Ω precision BNC coaxial cable.
- e. Set calibration generator for Std Ampl output of 50 mV.
- f. CHECK – that the readout is between 47.0 mV and 53.0 mV.
- g. Set SCOPE BW on.
- h. CHECK – the readout is between 47.7 mV and 52.3 mV.
- i. Set CH 2 INVERT on and select -PEAK from the VOLTMETER menu.
- j. CHECK – the readout is between -47.7 mV and -52.3 mV.
- k. Set SCOPE BW off.
- l. CHECK – the readout is between -47.0 mV and -53.0 mV.

- m. Select PK-PK from the VOLTMETER menu and set CH 2 INVERT off.
- n. CHECK – the readout is between 46.5 mV and 53.5 mV.
- o. Disconnect calibration generator.

4. 25 MHz +Peak, -Peak, and Peak-to-Peak Volts Accuracy

- a. Connect leveled sine-wave generator (SG 503) output to the CH 2 input via a 50 Ω BNC coaxial cable and a 50 Ω BNC termination.
- b. Set CH 2 VOLTS/DIV to 20 mV.
- c. Set leveled sine-wave generator output for a readout of 100.0 mV \pm 0.5 mV at 50 kHz.
- d. Set leveled sine-wave generator output for 25 MHz.
- e. CHECK – the readout is between 95.0 mV and 105.0 mV.
- f. Select -PEAK from the VOLTMETER menu.
- g. CHECK – the readout is between -46.0 mV and -54.0 mV.
- h. Select +PEAK from the VOLTMETER menu.
- i. CHECK – the readout is between 46.0 mV and 54.0 mV.

5. 100 MHz +Peak, -Peak, and Peak-to-Peak Volts Accuracy

- a. Set leveled sine-wave generator (SG 503) output frequency to 100 MHz.
- b. CHECK – the readout is between 34.4 mV and 54.0 mV.
- c. Select -PEAK from the VOLTMETER menu.
- d. CHECK – the readout is between -34.4 mV and -54.0 mV.
- e. Select PK-PK from the VOLTMETER menu.
- f. CHECK – the readout is between 69.7 mV and 107.0 mV.
- g. Disconnect the leveled sine-wave signal from the 2247A.

6. Gated Volts Accuracy

a. Set:

A SEC/DIV	0.5 ms
CH 2 VOLTS/DIV	10 mV

b. Press the VOLTMETER button and then select (TO GATED MEASMT MENU) from the VOLTMETER menu. Select GATED +PEAK from the GATED MEASMT menu.

c. Connect calibration generator (PG 506) Std Ampl output to the CH 2 input via a 50 Ω precision BNC coaxial cable. Set the generator to Std Ampl output, 50 mV.

- d. Set the \rightarrow control for minimum intensified zone width (counterclockwise rotation).
- e. CHECK—that the width of the dot is less than 0.2 division.
- f. Set the intensified dot to a positive peak of the displayed waveform, using the \leftarrow OR DELAY control.
- g. CHECK—the readout is between 47.0 mV and 53.0 mV.
- h. Set the intensified dot to a negative peak of the displayed waveform.
- i. CHECK—the readout is 0.0 mV \pm 0.5 mV.
- j. Disconnect the test equipment from the 2247A.

COUNTER/TIMER

Equipment Required (see Table 4-1)

Time-mark generator	50 Ω BNC coaxial cables
Digital delay	50 Ω BNC terminations
Leveled sine-wave generator	

1. Period

a. Set:

READOUT (Intensity)	For a viewable readout
A INTEN	For a viewable trace
VERTICAL MODE	CH 1
CH 1 VOLTS/DIV	0.5 V
CH 1 Input COUPLING	DC
Horizontal MODE	A
A SEC/DIV	1 μs
A/B SELECT	A Trigger
Horizontal POSITION	12 o'clock
TRIGGER MODE	AUTO LEVEL
TRIGGER SOURCE	VERT
TRIGGER CPLG	DC
TRIGGER SLOPE	↘ (positive-going)
TRIGGER HOLDOFF	MIN
TRIGGER LEVEL	12 o'clock
Measurements	All off (press CLEAR DISPLAY three times)
FOCUS	For best-defined display

- b. Connect time-mark generator (TG 501 Option 01) to the CH 1 input connector via a 50 Ω BNC coaxial cable and a 50 Ω BNC termination.
- c. Set the time-mark generator for 1 μs time markers.
- d. CHECK – the time markers are between two and four divisions high on the 2247A crt.
- e. Press the CURSOR VOLTS button. Select (TO AUTO TRACKING MENU). Select TRACK TRIG LVL. Select (MENU OFF) to remove the menu.

- f. Press the COUNTER/TIMER button. Select PERIOD.

NOTE

For all of the following steps, the Trigger level cursor must be in the middle of the waveform.

- g. CHECK – the Trigger tracking cursor falls in the middle of the waveform. If not, set A/B SELECT to B and press the TRIGGER MODE ↑ button. CHECK again.
- h. CHECK – for a readout between 0.999,989,9 μs (or 999.989,93 ns) and 1.000,010,1 μs.
- i. Disconnect the test equipment from the 2247A.

2. Width

a. Set:

VERTICAL MODE	CH 2 (CH 1 off)
CH 2 VOLTS/DIV	0.5 V
CH 2 INVERT	Off
A SEC/DIV	20 ns
A/B SELECT	A
A SLOPE	↘
A TRIGGER MODE	AUTO LEVEL
A TRIGGER SOURCE	VERT
A TRIGGER CPLG	DC

- b. Set the time-mark generator (TG 501 Option 01) to 0.1 μs.
- c. Connect the time-mark generator Marker Out through a 50 Ω coaxial cable and a 50 Ω terminator to the digital delay (DD 501) Events Input. Connect the time-mark generator Trigger Out through a 50 Ω coaxial cable and a 50 Ω terminator to the digital delay Start Input. Connect the digital delay Dly'd Trig Out through a 50 Ω coaxial cable and a 50 Ω terminator to the CH 2 input connector.

3. Rise Time Accuracy

- d. Set the digital delay Count to 00000, the Events Slope to +, and the Start Slope to +.
- e. Press the CURSOR VOLTS button. Select (TO AUTO TRACKING MENU). Check that TRACK TRIG LVL is underlined. (If it is not underlined, select TRACK TRIG LVL from the AUTO TRACKING menu.)
- f. Press the COUNTER/TIMER button. Select FREQ.
- g. Adjust the digital delay trigger levels so that all TRIG'D lights are on. Check for a frequency readout of approximately 10 MHz; if not, readjust the Events and/or Start trigger level on the digital delay until the readout is 10 MHz.
- h. Position the trace in the middle of the crt.
- i. Press the COUNTER/TIMER button. Select WIDTH.
- j. Set the digital delay Count to 09999. The trace should dim out. (Intensity may need to be readjusted to see the pulse.)
- k. Set the B Trigger SLOPE to \sim .
- l. CHECK—the Trigger tracking cursor falls in the middle of the waveform; if not, push the B TRIGGER MODE \uparrow button and CHECK again.
- m. WRITE DOWN—the readout (it should be about 20 ns) in μ s. (If the readout is 20 ns, write down 0.02 μ s.) Keep the readout in the 10 to 35 ns range by adjusting the digital delay trigger level slightly.
- n. Set the B SLOPE to \sim .
- o. WRITE DOWN—the readout in μ s. It should be about 999 μ s. ADD this to the readout noted in step m.
- p. CHECK—that the sum of the two readouts is between 999.986 and 1000.014 μ s.
- q. Disconnect the test equipment from the 2247A.

- a. Set:

VERTICAL MODE	CH 1 (CH 2 off)
CH 1 VOLTS/DIV	0.2 V
A SEC/DIV	0.2 μ s
A SLOPE	\sim

- b. Connect sine-wave generator (SG 503) to the CH 1 Input connector via a 50 Ω cable and a 50 Ω terminator.
- c. Set the leveled sine-wave generator Frequency to 1 MHz and the Ampl. Multiplier to X1.
- d. Press the COUNTER/TIMER button. Select FREQ.
- e. Adjust the sine-wave generator for five divisions of signal.
- f. Adjust the sine-wave generator for 0.998,000,0 MHz (998.000.00 kHz) to 1.002,000,0 MHz readout on the crt.
- g. Press the TIME button. Select (TO RISE/FALL MENU). Select TRIG 10–90. Select RISE.
- h. CHECK—for a readout between 260.11 and 330.23 ns.

NOTE

A 1 MHz sinewave has a 10–90% rise time of 295.167 ns; 20–80% rise time is 204.833 ns.

- i. Move the sine-wave generator to the EXT COUNTER/TIMER TIME BASE INPUT on the Rear Panel of the 2247A.
- j. Press the COUNTER/TIMER button, and select FREQ.
- k. CHECK—The “ct” readout in the right top corner of the crt has “ET” above it. (The readout may be flashing the message “FINDING PEAKS,” “NO START,” or “NO RISE.” That is okay.)

NOTE

If the above check fails, try to readjust the sine-wave generator frequency closer to 1 MHz. See steps c through f.

- l. Disconnect the test equipment from the 2247A.

EXTERNAL Z-AXIS, PROBE ADJUST, AND AUTO SETUP FUNCTIONS

Equipment Required (see Table 4-1)

Calibration generator	BNC T-connector
Two 50 Ω BNC coaxial cables	Test oscilloscope with a 10X probe
50 Ω Precision BNC coaxial cable	

1. Check External Z-Axis Input

a. Set:

READOUT (Intensity)	For a viewable readout
A INTEN	For a viewable trace
Vertical MODE	CH 1
CH 1 VOLTS/DIV	1 V
CH 2 INVERT	Off
SCOPE BW	Off
CH 1 Input COUPLING	DC
Horizontal MODE	A
A SEC/DIV	0.5 ms
A/B SELECT	A Trigger
Trigger MODE	AUTO LEVEL
Trigger CPLG	DC
Trigger SOURCE	VERT
Trigger SLOPE	↗ (positive-going)
Trigger HOLDOFF [†]	MIN
Measurements	All off (Press CLEAR DISPLAY three times)
FOCUS	For best defined display
Horizontal POSITION	12 o'clock

b. Connect calibration generator (PG 506) Std Ampl output to the CH 1 and the EXT Z-AXIS inputs via a 50 Ω precision BNC coaxial cable, a BNC T-connector, and two 50 Ω BNC coaxial cables. Set generator to Std Ampl output, 5 V.

c. Set A INTEN to maximum intensity.

d. CHECK—waveform display intensity starts decreasing at 1.8 V or less and the waveform is completely blanked out at 3.8 V.

e. Set A INTEN to midrange.

f. Disconnect the test equipment from the 2247A.

2. PROBE ADJUST Output

a. Set:

CH 1 Vertical MODE	10 mV
SEC/DIV	0.2 ms

b. Connect a 10X probe to the CH 1 input connector and connect the probe tip to the 2247A PROBE ADJUST output. (When using Tektronix coded probes the readout changes to .1V.)

c. CHECK—for a 5-division vertical display of PROBE ADJUST square-wave signal (square-wave period is typically 1 ms, within 25%).

3. AUTO SETUP Functional Check

a. Set:

CH 1 COUPLING	GND
CH 1 VOLTS/DIV	2 mV
A SEC/DIV	20 ns

b. Press the AUTO SETUP button.

c. Check that the Probe Adjust waveform is stably displayed on the upper half of the crt.

4. Run MAKE FACTORY SETTINGS Routine

a. Press the top and bottom Menu-Select buttons to display the SERVICE MENU.

- b. Press the down-arrow menu button to underline the INTERNAL SETTINGS MENU.
- c. Press SELECT.
- d. Press the down-arrow menu button once and press RUN to run the MAKE FACTORY SETTINGS routine.

- e. When the routine is finished, press the CLEAR DISPLAY button to return to the normal oscilloscope mode.

THIS COMPLETES THE PERFORMANCE CHECK PROCEDURE.

*This Document is a complete Scan from the original
Tektronix manual*

*For enquiries about our complete
High quality line of technical Manuals in PDF*

mailto : Qservice@otenet.gr

**SEE
OTHER
SIDE**

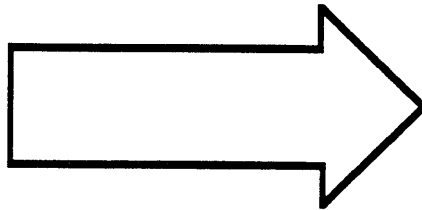

ADJUSTMENT PROCEDURE

INTRODUCTION

IMPORTANT – PLEASE READ BEFORE USING THIS PROCEDURE

PURPOSE

This Adjustment Procedure returns the instrument to conformance with the Performance Requirements as listed in the specification tables in section 1. Adjustments should be done only after the checks in the Performance Check Procedure (section 4) have indicated a need for a readjustment of the instrument.

+ 30°C, and the instrument must have had a warm-up period of at least 20 minutes.

TEST EQUIPMENT REQUIRED

The test equipment listed in Table 4-1 (section 4) is required to complete the Adjustment Procedure in this section and the Performance Check Procedure in section 4. Test equipment specifications described in Table 4-1 are the minimum necessary to provide accurate results; you must use equipment that meets or exceeds these specifications. Detailed operating instructions for test equipment are not given in this procedure; if more operating information is required, refer to the appropriate test equipment instruction manual.

When equipment other than that recommended is used, control settings of the test setup may need to be altered. If the exact item of equipment given as an example in Table 4-1 is not available, first check the Use column to verify use of the item. Then use the Minimum Specification column to determine whether other available test equipment can be used.

LIMITS AND TOLERANCES

The limits and tolerances stated in this procedure are instrument specifications only if they are listed in the Performance Requirements column of Table 1-1, Electrical Characteristics. Tolerances given are applicable only to the instrument under adjustment and do not include test equipment error. Adjustments must be made at an ambient temperature between +20°C and

PARTIAL PROCEDURES

This procedure is divided into subsections to permit adjustment of individual sections of the instrument (except the Power Supply) whenever a complete readjustment is not required. For example, if only the Vertical section fails to meet the Performance Requirements (or has had repairs made or components replaced), it can be readjusted with little or no effect on other sections of the instrument. However, if the Power Supply section has undergone repairs or adjustments that change the absolute value of any of the supply voltages, a complete readjustment of the instrument is required.

At the beginning of each subsection is a list of the initial front-panel control settings required to prepare the instrument for step 1 in that subsection. Each succeeding step within a subsection should then be done completely and in the sequence given to ensure that control settings will be correct for steps that follow.

INTERNAL ADJUSTMENTS AND ADJUSTMENT INTERACTION

Do not preset any internal controls, since that may make it necessary to recheck or readjust a major portion of the instrument when only a partial check or adjustment might otherwise have been required. To avoid unnecessary checks and adjustments, change an internal control setting only when a Performance Characteristic cannot be met with the original setting. When independently changing the setting of any internal control, always check Table 5-1 for possible interacting adjustments that might be required.

Specific interactions are called out within certain adjustment steps to indicate that the adjustments must be repeated until no further improvement is noted.

PREPARATION FOR ADJUSTMENT

It is necessary to remove the cabinet to do the Adjustment Procedure. See the cabinet removal instructions in the Maintenance section of this manual.

All test equipment items required to do the complete Adjustment Procedure are described in Table 4-1 at the beginning of section 4, Performance Check Procedure. The specific items of equipment needed to do each subsection in this procedure are listed at the beginning of that subsection.

Connect the test equipment and the 2247A to an appropriate ac-power source and allow 20 minutes warmup before making any adjustments.

INDEX TO ADJUSTMENT PROCEDURE

Power Supply, Display, and Z-Axis

1. Power Supply DC Levels (R2252) 5-4
2. Grid Bias (R2719) 5-5
3. Astigmatism (R2788) 5-5
4. Trace Rotation (Front Panel) 5-5
5. Geometry (R2784) 5-5
6. Readout Jitter (R724) 5-5

Vertical

1. Vertical Output Gain (R703) and Readout Vertical Centering (R260) 5-6
2. Ch 1 Step Balance (R12) 5-6
3. Ch 2 Step Balance (R22) 5-7
4. Ch 3 Step Balance (R141) 5-7
5. Ch 4 Step Balance (R161) 5-7
6. Ch 1 MF/LF Gain (R13) and Compensation (C1) 5-7

7. Ch 1 Input Capacitance (C114) 5-7
8. Ch 1 Input Compensation X10 (C11) 5-7
9. Ch 1 Input Compensation X100 (C10) ... 5-7
10. Ch 1 Gain (R211) 5-7
11. Ch 2 MF/LF Gain (R23) and Compensation (C2) 5-8
12. Ch 2 Input Capacitance (C124) 5-8
13. Ch 2 Input Compensation X10 (C21) 5-8
14. Ch 2 Input Compensation X100 (C20) ... 5-8
15. Ch 2 Gain (R221) 5-8
16. Ch 3 MF/LF Compensation (C134) 5-8
17. Ch 3 Gain (R231) 5-8
18. Ch 4 MF/LF Compensation (C154) 5-9
19. Ch 4 Gain (R241) 5-9
20. Delay-line HF Compensation (R272, R273, R275, C274, C273) 5-9
21. Ch 3 HF Compensation (C138) 5-9
22. Ch 4 HF Compensation (C158) 5-9
23. Ch 1 and Ch 2 Bandwidth Check 5-10
24. Ch 3 and Ch 4 Bandwidth Check 5-10

Horizontal

1. Horizontal X1 Gain (Timing) (R826) 5-11
2. Horizontal X10 Gain (Timing) (R825) ... 5-11
3. Readout Horizontal Gain (R823) and MAG Registration (R809) 5-11
4. A 0.5 μ s Timing (C314) 5-12
5. B 0.5 μ s Timing (C329) 5-12
6. 2 ns Timing (C807, C814) 5-12
7. X Gain (R827) 5-12

Measurement Bandwidth and Self Characterization

1. Volts Cal (R920) 5-13
2. B Trigger Bandwidth (R455) 5-13
3. Self Characterization 5-13

Counter/Timer

1. Counter/Timer 10MHz CAL (C1904) 5-15

POWER SUPPLY, DISPLAY, AND Z-AXIS

Equipment Required (see Table 4-1)

Calibration generator	Time-mark generator
Digital multimeter (DMM)	50 Ω coaxial cable
Leveled sine-wave generator	50 Ω termination
Test oscilloscope with 10X probe	

See ADJUSTMENT LOCATIONS

at the back of this manual for test points and adjustment locations.

INITIAL CONTROL SETTINGS

Set:

Vertical MODE	CH 1
CH 1 COUPLING	DC
VOLTS/DIV	0.1 V
Vertical POSITION	
Controls	12 o'clock
Horizontal MODE	A
A/B SELECT	A
SEC/DIV	0.1 ms
Trigger LEVEL	12 o'clock
HOLD OFF	MIN (ccw)
SLOPE	↗
Trigger MODE	AUTO LEVEL
Trigger SOURCE	CH 1
Trigger CPLG	DC
MEASUREMENTS	Off
MENU Displays	Off
A INTEN	10 o'clock
READOUT	12 o'clock
FOCUS	For well-defined display
SCALE ILLUM	Fully ccw

- b. CHECK – Voltage reading is within the range given in Table 5-2.
- c. Move DMM positive lead to each of the other supply voltages in Table 5-2 and check that voltage ranges are within limits.

NOTE

If all supply voltages are within the limits given in Table 5-2, it is not necessary to adjust the power supply. If voltages are not within limits, you will have to adjust the +7.5 V supply, recheck the other voltages, and continue with a complete readjustment of the instrument.

Table 5-2
Power Supply Voltage Limits

Nominal Supply Voltage	Test Point (+ lead)	Limits (0°C to 50°C)	
		Min	Max
+130 V	J1204-11	+127 to	+135
+58 V	J1204-10	+55.7 to	+59.2
+15 V	J1204-7	+14.6 to	+15.6
+7.5 V	J1204-8	+7.4 to	+7.6
+5.0 V	J1204-1,2	+5.0 to	+5.3
-5.0 V	J1204-5	-5.1 to	-5.4
-7.5 V	J1204-9	-7.4 to	-7.8
-15 V	J1204-6	-15.5 to	-16.6

PROCEDURE

1. Power Supply DC Levels (R2252)

- a. Connect a Digital Multimeter (DMM) negative lead to chassis ground. Connect positive lead to first test point listed in Table 5-2 (all test points on J1204, Main board).

- d. Connect a digital multimeter (DMM) negative lead to chassis ground and positive lead to +7.5 V test point (J1204–8).
- e. ADJUST – +7.5 V ADJ (R2252) for +7.5 V and check that all supply voltages in Table 5–2 are within limits. The +7.5 V Adjustment is accessible through the right side frame.
- f. Disconnect digital multimeter.

2. Grid Bias (R2719)

- a. Set:

HORIZ MODE	X–Y
CH 1 VOLTS/DIV	5 V
CH 1 COUPLING	GND
SCOPE BW	On
A INTEN	Fully ccw (off)
B INTEN	Fully ccw (off)
READOUT (Intensity)	Fully ccw (off)
SCALE ILLUM	Fully ccw (off)
- b. ADJUST – GRID BIAS (R2719) for a visible dot.
- c. Position dot just off center screen with vertical or horizontal POSITION controls.
- d. Set FOCUS control for a well-defined dot.
- e. ADJUST – GRID BIAS (R2719) so that the dot is no longer visible. Do not continue adjusting R2719 past the point where the dot disappears.

3. Astigmatism (R2788)

- a. Set:

HORIZ MODE	A
A INTEN	10 o'clock
READOUT (Intensity)	12 o'clock
SEC/DIV	5 μ s
VAR SEC/DIV	Detent (fully cw)
CH 1 VOLTS/DIV	10 mV
CH 1 COUPLING	DC
- b. Connect leveled sine-wave generator output to the CH 1 input connector via a 50 Ω BNC coaxial cable and a 50 Ω BNC termination. Set for a 5-division display at 50 kHz.
- c. ADJUST – ASTIG (R2788) together with front-panel FOCUS control for best overall resolution of the sine-wave display.
- d. Disconnect leveled sine-wave generator.

4. Trace Rotation (Front Panel)

- a. Set CH 1 COUPLING to GND.
- b. Position trace to center horizontal graticule line and beginning of trace to first vertical graticule line.
- c. ADJUST – TRACE ROTATION (front panel) to align trace parallel with center horizontal graticule line.

5. Geometry (R2784)

- a. Set:

CH 1 VOLTS/DIV	0.1 V
CH 1 COUPLING	DC
SEC/DIV	50 μ s
READOUT (Intensity)	Fully ccw (off)
- b. Connect time-mark generator to CH 1 via 50 Ω cable and 50 Ω termination. Display 10 μ s time markers.
- c. Position base trace below bottom graticule line.

NOTE

It may be necessary to increase the A intensity during this step to see the time markers.

- d. ADJUST – GEOM (R2784) for minimum bowing of time markers across the full graticule area. Vertical bowing of time marker across screen should be no more than 0.1 division.
- e. Disconnect time-mark generator.

6. Readout Jitter (R724)

- a. Set:

READOUT (Intensity)	12 o'clock
SEC/DIV	10 ms
CH 1 COUPLING	DC
A INTEN	Fully ccw (off)
- b. Connect calibration generator (PG 506) Std Ampl output to CH 1 input via 50 Ω precision coaxial cable. Set generator for Std Ampl and 1 volt.
- c. ADJUST – Readout Jitter (R724) for the least amount of jitter or sway in the readout.
- d. Disconnect calibration generator.

VERTICAL

Equipment Required (see Table 4-1)

Calibration generator	50 Ω termination
Leveled sine-wave generator	Precision normalizer (20 pF)
50 Ω coaxial cable	

See **ADJUSTMENT LOCATIONS**

at the back of this manual for locations of test points and adjustments.

INITIAL CONTROL SETTINGS

1. Set:

Vertical MODE	CH 1 and CH 2
INPUT COUPLING	DC
VOLTS/DIV	0.1 V
Vertical POSITION Controls	12 o'clock
Horizontal MODE	A
A/B SELECT	A
SEC/DIV	0.1 ms
Trigger LEVEL	12 o'clock
HOLD OFF	MIN (ccw)
SLOPE	
Trigger MODE	AUTO LEVEL
Trigger SOURCE	VERT
Trigger CPLG	DC
MEASUREMENTS	Off
MENU Displays	Off
A INTEN	10 o'clock
READOUT	12 o'clock
FOCUS	For well-defined display
SCALE ILLUM	Fully ccw

PROCEDURE

1. Vertical Output Gain (R703) and Readout Vertical Centering (R260)

- a. Run ADJUST VERTICAL OUTPUT routine.

Access the SERVICE MENU by simultaneously pressing the top and bottom menu-select buttons.

Press the down arrow on the SERVICE MENU to underline INTERNAL SETTINGS MENU and then press SELECT. Press the down arrow on the INTERNAL SETTINGS MENU to underline ADJUST VERTICAL OUTPUT and then press RUN to run the ADJUST VERTICAL OUTPUT routine.

NOTE

For this adjustment, the 2247A must be placed in the "normal" operating position to avoid incorrect alignment due to effects of the earth's magnetic field.

- b. ADJUST-VO GAIN (R703) and RO VERT CENTERING (R260) alternately until dashed lines produced by the diagnostics are aligned with dotted lines on the graticule.
- c. Press the CLEAR DISPLAY button to return to the normal oscilloscope display.

2. CH 1 Step Balance (R12)

- a. Set:

Vertical MODE	CH 1 (CH 2 off)
CH 1 COUPLING	GND
SCOPE BW	On

- b. Position trace to center of horizontal graticule line.
- c. ADJUST-R12 (CH 1 STEP BALANCE) so the trace does not move vertically while switching CH 1 VOLTS/DIV switch from 10 mV to 50 mV.

3. CH 2 Step Balance (R22)

a. Set:

Vertical MODE	CH 2 (CH 1 off)
CH 2 COUPLING	GND

- b. Position trace to center horizontal graticule line.
- c. ADJUST – R22 (CH 2 STEP BALANCE) so that trace does not move vertically while switching CH 2 VOLTS/DIV switch from 10 mV to 50 mV.

4. CH 3 Step Balance (R141)

- a. Set Vertical MODE to CH 3 (CH 2 off).
- b. Position trace to center horizontal graticule line.
- c. ADJUST – R141 (CH 3 STEP BALANCE) so that trace does not move vertically while switching CH 3 VOLTS/DIV switch from 0.1 V to 0.5 V.

5. CH 4 Step Balance (R161)

- a. Set Vertical MODE to CH 4 (CH 3 off).
- b. Position trace to center horizontal graticule line.
- c. ADJUST – R161 (CH 4 STEP BALANCE) so that trace does not move vertically while switching CH 4 VOLTS/DIV switch from 0.1 V to 0.5 V.

6. CH 1 MF/LF Gain (R13) and Compensation (C1)

a. Set:

Vertical MODE	CH 1 (CH 4 off)
CH 1 VOLTS/DIV	50 mV
CH 1 COUPLING	DC
SEC/DIV	50 μ s

- b. Connect calibration generator (PG 506) High Ampl output to CH 1 input via 50 Ω BNC coaxial cable and 50 Ω BNC termination. Set generator for High Ampl. Set Period to 10 kHz and adjust Pulse Amplitude for a 5-division display.
- c. ADJUST – R13 (CH 1 MF/LF GAIN) and C1 (CH 1 MF/LF COMP) for the flattest response.

7. CH 1 Input Capacitance (C114)

a. Set:

CH 1 VOLTS/DIV	10 mV
SEC/DIV	0.2 ms

- b. Add precision normalizer between termination and CH 1 input connector. Set calibration generator Period to 1 kHz and adjust Pulse Amplitude for 5-division display.
- c. ADJUST – C114 (CH 1 INPUT CAPACITANCE) for best flat top.
- d. Remove precision normalizer from the input cable.

8. CH 1 Input Compensation X10 (C11)

a. Set:

CH 1 VOLTS/DIV	0.1 V
SEC/DIV	50 μ s

- b. Set calibration generator Period to 10 kHz and adjust Pulse Amplitude for a 5-division display.
- c. ADJUST – C11 (CH 1 INPUT COMP X10) for flattest response.

9. CH 1 Input Compensation X100 (C10)

- a. Set CH 1 VOLTS/DIV to 1 V.
- b. Set calibration generator amplitude for a 5-division display.
- c. ADJUST – C10 (CH 1 INPUT COMP X100) for flattest response.

10. CH 1 Gain (R211)

- a. Set calibration generator to Std Ampl and Amplitude to 50 mV. Remove 50 Ω termination from input cable.
- b. Set:
- | | |
|----------------|--------|
| CH 1 VOLTS/DIV | 10 mV |
| SEC/DIV | 0.2 ms |
- c. ADJUST – CH 1 GAIN (R211) for exactly a 5-division display amplitude.

11. CH 2 MF/LF Gain (R23) and Compensation (C2)

a. Set:

Vertical MODE	CH 2 (CH 1 off)
CH 2 VOLTS/DIV	50 mV
CH 2 COUPLING	DC
SEC/DIV	50 μ s

- b. Move calibration generator signal to CH 2 input. Add 50 Ω termination.
- c. Set calibration generator for High Ampl. Set Period to 10 kHz and adjust Pulse Amplitude for 5-division display.
- d. ADJUST – R23 (CH 2 MF/LF GAIN) and C2 (CH 2 MF/LF COMP) for flattest response.

12. CH 2 Input Capacitance (C124)

a. Set:

CH 2 VOLTS/DIV	10 mV
SEC/DIV	0.2 ms

- b. Add precision normalizer between termination and CH 2 input connector. Set calibration generator Period to 1 kHz and adjust Pulse Amplitude for 5-division display.
- c. ADJUST – C124 (CH 2 INPUT CAPACITANCE) for best flat top.
- d. Remove precision normalizer from the input cable.

13. CH 2 Input Compensation X10 (C21)

a. Set:

CH 2 VOLTS/DIV	0.1 V
SEC/DIV	50 μ s

- b. Set calibration generator Period to 10 kHz and adjust Pulse amplitude for a 5-division display.
- c. ADJUST – C21 (CH 2 INPUT COMP X10) for flattest response.

14. CH 2 Input Compensation X100 (C20)

- a. Set CH 2 VOLTS/DIV to 1 V.
- b. Set calibration generator amplitude for a 5-division display.
- c. ADJUST – C20 (CH 2 INPUT COMP X100) for flattest response.

15. CH 2 Gain (R221)

- a. Set calibration generator to Std Ampl and Amplitude to 50 mV. Remove 50 Ω termination from the input cable.
- b. Set:
- | | |
|----------------|--------|
| CH 2 VOLTS/DIV | 10 mV |
| SEC/DIV | 0.2 ms |
- c. ADJUST – CH 2 GAIN (R221) for exactly a 5-division display amplitude.

16. CH 3 MF/LF Compensation (C134)

a. Set:

Vertical MODE	CH 3 (CH 2 off)
CH 3 VOLTS/DIV	0.1 V
SEC/DIV	50 μ s

- b. Move calibration generator signal to CH 3 input. Add 50 Ω termination.
- c. Set calibration generator for High Ampl. Set Period to 10 kHz and adjust Pulse Amplitude for a 5-division display.
- d. ADJUST – C134 (CH 3 MF/LF COMP) for flattest response.

17. CH 3 Gain (R231)

a. Set:

CH 3 VOLTS/DIV	0.5 V
SEC/DIV	0.2 ms

- b. Set calibration generator for Std Ampl. Set Amplitude to 2 V. Remove 50 Ω termination.
- c. ADJUST – CH 3 GAIN (R231) for exactly 4 divisions display amplitude.

18. CH 4 MF/LF Compensation (C154)

- a. Set:
- | | |
|----------------|-----------------|
| Vertical MODE | CH 4 (CH 3 off) |
| CH 4 VOLTS/DIV | 0.1 V |
| SEC/DIV | 50 μ s |
- b. Move calibration generator signal to CH 4 input. Add 50 Ω termination.
- c. Set calibration generator for High Ampl. Set Period to 10 kHz and adjust Pulse Amplitude for a 5-division display.
- d. ADJUST—C154 (CH 4 MF/LF COMP) for flattest response.

19. CH 4 Gain (R241)

- a. Set:
- | | |
|----------------|--------|
| CH 4 VOLTS/DIV | 0.5 V |
| SEC/DIV | 0.2 ms |
- b. Set calibration generator for Std Ampl. Set Amplitude to 2 V. Remove 50 Ω termination.
- c. ADJUST—CH 4 GAIN (R241) for exactly a 4-division display amplitude.
- d. Disconnect calibration generator from CH 4.
- e. Run the SELF CAL MEASUREMENTS routine. (See Self Characterization in the Measurement Bandwidth and Self Characterization subsection of this procedure.)

20. Delay-Line HF Compensation (R272, R273, R275, C274, C273)

- a. Set:
- | | |
|----------------|-----------------|
| Vertical MODE | CH 1 (CH 4 off) |
| CH 1 VOLTS/DIV | 50 mV |
| SEC/DIV | 20 ns |
| SCOPE BW | Off |
- b. Connect calibration generator positive-going Fast Rise Output to the CH 1 input via a 50 Ω precision coaxial cable and a 50 Ω termination.
- c. Set calibration generator for Fast Rise at 1 MHz and adjust Pulse Amplitude for a 5-division display.

- d. Position the top of display to the center horizontal graticule line.
- e. Set X10 MAG on (for a 2 ns per division display) and turn the Horizontal POSITION control clockwise until the rising edge of the pulse is displayed.
- f. ADJUST—DLY LINE HF COMP adjustments (R272, R273, R275) for flattest response and (C274, C273) for sharpest front corner with minimum overshoot. Figure 5-1 shows the area of the waveform affected by each adjustment.

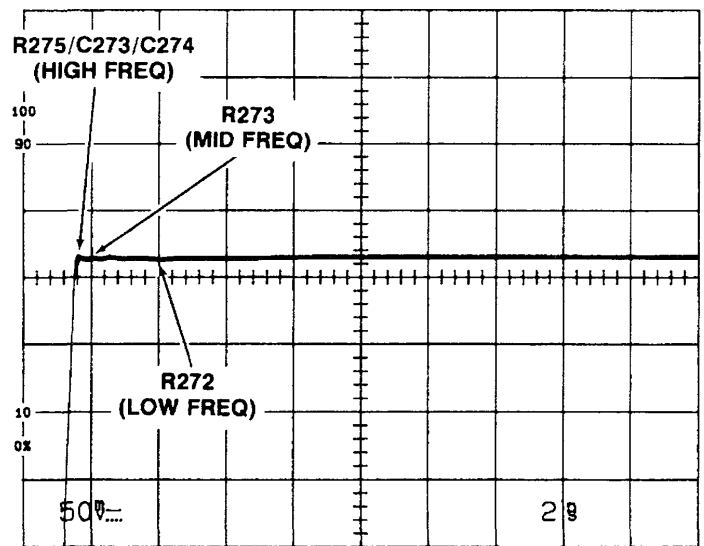

(6081-14)6367-38

Figure 5-1. Areas of waveform affected by HF compensation.

21. CH 3 HF Compensation (C138)

- a. Set:
- | | |
|----------------|-----------------|
| Vertical MODE | CH 3 (CH 1 off) |
| CH 3 VOLTS/DIV | 0.5 V |
| X10 MAG | Off |
- b. Move calibration generator signal to CH 3. Set Pulse Amplitude to maximum to obtain about a 2.5 division display.
- c. ADJUST—C138 (CH 3 HF COMP) for flattest response.

22. CH 4 HF Compensation (C158)

- a. Set:
- | | |
|----------------|-----------------|
| Vertical MODE | CH 4 (CH 3 off) |
| CH 4 VOLTS/DIV | 0.5 V |

- b. Move calibration generator signal to CH 4.
- c. ADJUST—C158 (CH 4 HF COMP) for flattest response.
- d. Disconnect calibration generator.

- g. Set:

Vertical MODE	CH 2 (CH 1 off)
CH 2 VOLTS/DIV	2 mV
- h. Repeat the complete bandwidth check procedure for Channel 2.

23. CH 1 and CH 2 Bandwidth Check

- a. Set:

Vertical MODE	CH 1 (CH 4 off)
CH 1 VOLTS/DIV	2 mV
SEC/DIV	0.1 ms
- b. Connect leveled sine-wave generator output to the CH 1 input via a 50 Ω precision coaxial cable and a 50 Ω BNC termination.
- c. Set leveled sine-wave generator output for a six-division signal amplitude at 50 kHz.
- d. CHECK—the displayed signal amplitude is 4.2 divisions or more as the frequency is increased to 90 MHz.
- e. Repeat the frequency setup and CHECK procedure for VOLTS/DIV settings of 5 mV, 50 mV, and 0.5 V, except perform CHECK at 100 MHz.
- f. Move the test signal to the CH 2 input.

24. CH 3 and CH 4 Bandwidth Check

- a. Set:

Vertical MODE	CH 3 (CH 2 off)
CH 3 VOLTS/DIV	0.1 V
- b. Move the leveled sine-wave generator signal to the CH 3 input.
- c. Set the generator output for a six-division signal display at 50 kHz.
- d. CHECK—signal display amplitude is 4.2 divisions or more as the frequency is increased to 100 MHz.
- e. Repeat the procedure for 0.5 VOLTS/DIV setting.
- f. Move the test signal to the CH 4 input.
- g. Set:

Vertical MODE	CH 4 (CH 3 off)
CH 4 VOLTS/DIV	0.1 V
- h. Repeat the procedure for CH 4.
- i. Disconnect leveled sine-wave generator.

HORIZONTAL

Equipment Required (see Table 4-1)

Time-mark generator	50 Ω coaxial cable
Calibration generator	50 Ω termination

See **ADJUSTMENT LOCATIONS**

at the back of this manual for locations of test points and adjustments.

INITIAL CONTROL SETTINGS

Set:

Vertical MODE	CH 1 and CH 2
Input COUPLING	DC
VOLTS/DIV	0.1 V
Vertical POSITION Controls	12 o'clock
Horizontal MODE	A
A/B SELECT	A
SEC/DIV	0.1 ms
Trigger LEVEL	12 o'clock
HOLDOFF	MIN (ccw)
SLOPE	
Trigger MODE	AUTO LEVEL
Trigger SOURCE	VERT
Trigger CPLG	DC
MEASUREMENTS	Off
MENU Displays	Off
A INTEN	10 o'clock
READOUT	12 o'clock
FOCUS	For well-defined display
SCALE ILLUM	Fully ccw

- Position display to center of screen.
- ADJUST – HORIZONTAL 1X GAIN (R826) for one time marker per division over the center 8 divisions.

2. Horizontal X10 Gain (Timing) (R825)

- Set X10 MAG to On.
- Set time-mark generator for 10 μ s time markers.
- Position display to center of screen.
- ADJUST – HORIZONTAL X10 GAIN (R825) for one time marker per division over the center 8 divisions.

3. Readout Horizontal Gain (R823) and MAG Registration (R809)

a. Set:

X10 MAG	Off
SEC/DIV	1 ms
A INTEN	ccw (off)

- Press the TIME button and then select \leftarrow SEC \rightarrow from the menu.
- Rotate the \leftarrow OR DELAY control counterclockwise and the \rightarrow control clockwise until cursors stop moving.
- ADJUST – MAG REG (R809) and RO HORIZ GAIN (R823) alternately until the reference cursor lines up exactly with the left graticule line and the delta cursor lines up exactly with the right graticule line.
- Press CLEAR DISPLAY button once to remove CURSORS from screen.

PROCEDURE

1. Horizontal X1 Gain (Timing) (R826)

a. Set:

Vertical MODE	CH 1 (CH 2 off)
CH 1 VOLTS/DIV	0.5 V

- Connect time-mark generator to CH 1 input via 50 Ω BNC coaxial cable and 50 Ω BNC termination. Set generator for 0.1 ms time markers.

- f. Set:

SEC/DIV	20 μ s
A INTEN	10 o'clock
- g. Set time-mark generator for 0.1 ms time markers.
- h. Position rising edge of middle time marker to the center vertical graticule line.
- i. Set X10 MAG to On.
- j. INTERACTION – between MAG Registration and horizontal positioning of the time cursors. Check for less than 0.5 division shift of time marker rising edge between MAG on and MAG off. If not within 0.5 division, recheck the accuracy of R809 and R823 adjustments; readjust if necessary.

4. A 0.5 μ s Timing (C314)

- a. Set:

X10 MAG	Off
SEC/DIV	0.5 μ s
- b. Set time mark generator for 0.5 μ s time markers.
- c. ADJUST – A 0.5 μ s TIMING (C314) for one time marker per division over the center 8 divisions.

5. B 0.5 μ s Timing (C329)

- a. Set:

Horizontal MODE	B
SEC/DIV (B)	0.5 μ s
B Trigger MODE	RUNS AFTER
B INTEN	10 o'clock
- b. Rotate the \leftarrow OR DELAY control counterclockwise until the readout displays “?0.000 μ s”.
- c. ADJUST – B 0.5 μ s TIMING (C329) for one time marker per division over the center 8 divisions.

6. 2 ns Timing (C807, C814)

- a. Set:

Horizontal MODE	A
SEC/DIV	20 ns
X10 MAG	On
CH 1	0.1 mV
Horizontal POSITION	12 o'clock
- b. Set time-mark generator for 5 ns time markers.

- c. ADJUST – 2 ns TIMING (C807, C814) for 1 cycle for each 2.5 divisions over the center 8 divisions. See Figure 5-2. Use the vertical transition of the sine wave instead of the peaks for better accuracy.

NOTE

It may be necessary to readjust the Trigger LEVEL to get a stable display of the 5 ns time markers.

- d. INTERACTION – between C807 and C814. Readjust as necessary to make the timing at 2.5, 5, and 7.5 divisions within ± 0.2 division (1 minor division).
- e. Disconnect time-mark generator.

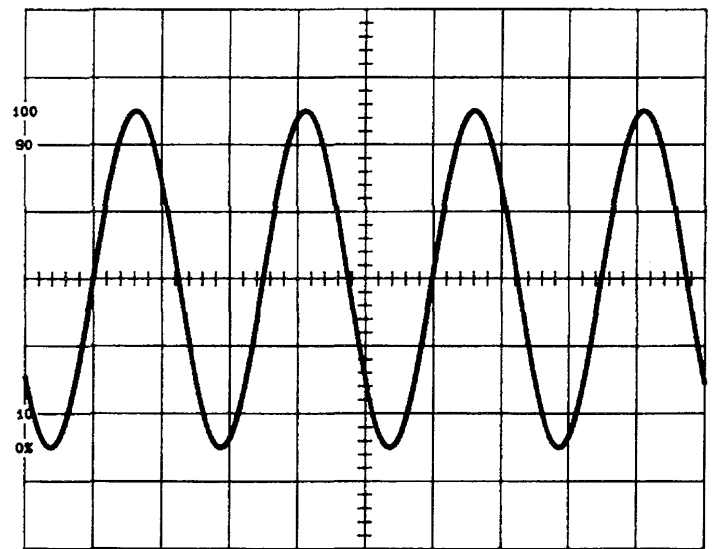

6081-15

Figure 5-2. 2 ns Timing.

7. X Gain (R827)

- a. Set:

X10 MAG	Off
Horizontal MODE	X-Y
Vertical MODE	CH 2
CH 1 VOLTS/DIV	10 mV
A INTEN	For best viewing
- b. Connect calibration generator Std Ampl output to CH 1 input via 50 Ω coaxial cable. Set generator for Std Ampl. Set Amplitude to 50 mV.
- c. ADJUST – X GAIN (R827) for 5 divisions of horizontal signal.
- d. Disconnect calibration generator.

MEASUREMENT BANDWIDTH AND SELF CHARACTERIZATION

Equipment Required (see Table 4-1)

Digital multimeter (DMM)
Leveled sine-wave generator

50 Ω coaxial cable

See **ADJUSTMENT LOCATIONS**

at the back of this manual for locations of test points and adjustments.

INITIAL CONTROL SETTINGS

Set:

Vertical MODE	CH 1 and CH 2
Input COUPLING	DC
VOLTS/DIV	0.1 V
Vertical POSITION	
Controls	12 o'clock
Horizontal MODE	A
A/B SELECT	A
SEC/DIV	0.1 ms
Trigger LEVEL	12 o'clock
HOLD OFF	MIN (ccw)
SLOPE	
Trigger MODE	AUTO LEVEL
Trigger SOURCE	VERT
Trigger CPLG	DC
MEASUREMENTS	Off
MENU Displays	Off
A INTEN	10 o'clock
READOUT	12 o'clock
FOCUS	For well-defined display
SCALE ILLUM	Fully ccw

PROCEDURE

1. Volts Cal (R920)

- Connect digital multimeter (DMM) LO lead to the CH 1 BNC ground shell and the high lead to R921 pin 6.
- ADJUST – VOLTS CAL (R920) so the DMM reads 0.250 V.

2. B Trigger Bandwidth (R455)

a. Set:

Vertical MODE	CH 2 (CH 1 off)
CH 2 VOLTS/DIV	20 mV
SEC/DIV	50 μ s

- Preset potentiometer R455 to midrange.
- Run the SELF CAL routine. Press CH 1/CH 2 VOLT-METER button and select SELF CAL.
- Connect leveled sine-wave generator output to the CH 2 input connector via a 50 Ω BNC precision coaxial cable and a 50 Ω BNC termination. Set generator for a 5-division display at 50 kHz.
- Press the VOLTMETER button and then select PK-PK from the VOLTMETER menu.
- Set output of the leveled sine-wave generator for a peak-to-peak readout display of 100 mV \pm 0.5 mV. Adjust generator to 110 MHz.
- ADJUST – B TRIG BANDWIDTH (R455) for a peak-to-peak readout of 75 mV \pm 0.5 mV.

3. Self Characterization

- Run the SELF CAL MEASUREMENTS routine. Press both top and bottom menu-item select buttons. Select SELF CAL MEASUREMENTS and press RUN to start the routine. When the routine is done, continue with part b or press QUIT to return to normal oscilloscope mode.

Adjustment Procedure – 2247A Service

- b. Run MAKE FACTORY SETTINGS routine. Press the down-arrow button to select the INTERNAL SETTINGS MENU. Press SELECT, then press the down-arrow button to select MAKE FACTORY SETTINGS. Press RUN to start the routine. When done, press QUIT to return to normal oscilloscope mode.

COUNTER/TIMER

Equipment Required (see Table 4-1)

Time-mark generator	50 Ω termination
50 Ω coaxial cable	

INITIAL CONTROL SETTINGS

Set:

Vertical MODE	CH 1
Input COUPLING	DC
CH 1 VOLTS/DIV	0.2 V
Vertical POSITION	
Controls	12 o'clock
Horizontal MODE	A
A/B SELECT	A
SEC/DIV	0.2 μ s
Trigger LEVEL	12 o'clock
Trigger HOLDOFF	MIN (ccw)
Trigger SLOPE	
Trigger MODE	AUTO LEVEL
Trigger SOURCE	VERT
Trigger CPLG	DC
MEASUREMENTS	Off
MENU Displays	Off
A INTEN	10 o'clock
READOUT	12 o'clock
FOCUS	For well-defined display
SCALE ILLUM	Fully ccw

PROCEDURE

NOTE

The 2247A must be warmed up for at least 30 minutes before making the following adjustment.

1. Counter/Time 10MHz CAL Adjustment (C1904)

- Connect time-mark generator (TG 501 Option 01) to the CH 1 input connector via a 50 Ω coaxial cable and a 50 Ω termination.
- Set the time-mark generator for 1 μ s time markers.
- Press COUNTER/TIMER button and then select FREQ. Set A/B SELECT to B. Press the Trigger MODE \uparrow button until B AUTO LEVEL MODE is selected or press the \uparrow button once if already in B AUTO LEVEL MODE.

NOTE

Figure 5-3 shows the location of C1904 (10MHz CAL adjustment). C1904 is located near the rear edge of the Processor board (the top board in the 2247A).

- ADJUST—C1904 (10MHz CAL) on the Processor board for a readout of 999.994,10 to 999.995,10 kHz (0.999,994,1 to 0.999,995,1 MHz).
- Disconnect the test equipment.

MAINTENANCE

This section of the manual contains information on static-sensitive components, preventive maintenance, troubleshooting, and corrective maintenance. General information regarding the care and handling of semiconductor devices is provided in "Static-Sensitive Components," and routine cleaning and inspection are

covered in "Preventive Maintenance." Internal testing capabilities and diagnostic test routines are included in the "Troubleshooting" subsection. The "Corrective Maintenance" part of this section includes circuit board removal procedures, maintenance aids, and soldering techniques.

STATIC-SENSITIVE COMPONENTS

The following precautions apply when performing any maintenance involving internal access to the instrument.



Static discharge can damage any semiconductor component in this instrument.

This instrument contains electrical components that are susceptible to damage from static discharge. Table 6-1 lists the relative susceptibility of various classes of semiconductors. Static voltages of 1 kV to 30 kV are common in unprotected environments.

When performing maintenance, observe the following precautions to avoid component damage:

1. Minimize handling of static-sensitive components.
2. Transport and store static-sensitive components or assemblies in their original containers or on a metal rail. Label any package that contains static-sensitive components or assemblies.
3. Discharge the static voltage from your body by wearing a grounded antistatic wrist strap while handling these components. Servicing static-sensitive components or assemblies should be performed only at a static-free work station by qualified service personnel.

Table 6-1

Relative Susceptibility to Static-Discharge Damage

Semiconductor Classes	Relative Susceptibility Levels ^a
MOS or CMOS microcircuits or discretes, or linear microcircuits with MOS inputs (Most Sensitive)	1
ECL	2
Schottky signal diodes	3
Schottky TTL	4
High-frequency bipolar transistors	5
JFET	6
Linear microcircuits	7
Low-power Schottky TTL	8
TTL (Least Sensitive)	9

^a Voltage equivalent for levels (voltage discharged from a 100-pF capacitor through a resistance of 100 Ω):

1 = 100 to 500 V	6 = 600 to 800 V
2 = 200 to 500 V	7 = 400 to 1000 V (est)
3 = 250 V	8 = 900 V
4 = 500 V	9 = 1200 V
5 = 400 to 600 V	

4. Keep anything capable of generating or holding a static charge off the work station surface.

5. Keep the component leads shorted together whenever possible.
6. Pick up components by their bodies, never by their leads.
7. Do not slide the components over any surface.
8. Avoid handling components in areas that have a floor or work-surface covering capable of generating a static charge.
9. Use a soldering iron that is connected to earth ground.
10. Use only approved antistatic, vacuum-type desoldering tools for component removal.

PREVENTIVE MAINTENANCE

INTRODUCTION

Preventive maintenance consists of cleaning, inspection, and checking instrument performance. Preventive maintenance on a regular basis may prevent instrument malfunction and improve instrument reliability. The required frequency of maintenance depends on the severity of the environment in which the instrument is used. A good time to do preventive maintenance is just before instrument adjustment.

INSPECTION AND CLEANING

Inspect and clean the 2247A as often as operating conditions require. Accumulation of dirt in the instrument can cause overheating and component breakdown. Dirt on components acts as an insulating blanket, preventing efficient heat dissipation. It also provides an electrical conduction path that could result in instrument failure, especially under high-humidity conditions



Do not use chemical cleaning agents which might damage the plastics used in this instrument. Use a nonresidue-type cleaner, preferably isopropyl alcohol or a solution of 1% mild detergent and 99% water. Before using any other type of cleaner, consult your Tektronix Service Center or representative.

Exterior

INSPECTION. Inspect the external portions of the instrument for damage, wear, and missing parts; use Table 6-2 as a guide. Instruments that appear to have been dropped or otherwise abused should be checked thoroughly to verify correct operation and performance. Deficiencies that could cause personal injury or could lead to further instrument damage should be repaired immediately.



Do not allow moisture to get inside the instrument during external cleaning. Use only enough liquid to dampen the cloth or applicator.

CLEANING. Loose dust on the outside of the instrument can be removed with a soft cloth or small soft-bristle brush. The brush is particularly useful on and around the controls and connectors. Remove remaining dirt with a soft cloth dampened in a mild detergent-and-water solution. Do not use abrasive cleaners.

Clean the light filters and the crt face with a soft lint-free cloth dampened with either isopropyl alcohol or a mild detergent-and-water solution.

Interior

To clean or inspect the inside of the instrument, first refer to the Removal and Replacement Instructions in the Corrective Maintenance part of this section.

Table 6-2
External Inspection Checklist

Item	Inspect For	Repair Action
Cabinet, Front Panel, and Cover	Cracks, scratches, deformations, damaged hardware or gaskets.	Touch up paint scratches and replace defective components.
Front-panel controls	Missing, damaged, or loose knobs, buttons, and controls.	Repair or replace missing or defective items.
Connectors	Broken shells, cracked insulation, and deformed contacts. Dirt in connectors.	Replace defective parts. Clean or wash out dirt.
Carrying Handle	Correct operation.	Replace defective parts.
Accessories	Missing items or parts of items, bent pins, broken or frayed cables, and damaged connectors.	Replace damaged or missing items, frayed cables, and defective parts.

Table 6-3
Internal Inspection Checklist

Item	Inspect For	Repair Action
Circuit Boards	Loose, broken, or corroded solder connections. Burned circuit boards. Burned, broken, or cracked circuit-run plating.	Clean solder corrosion with an eraser and flush with isopropyl alcohol. Resolder defective connections. Determine cause of burned items and repair. Repair defective circuit runs.
Resistors	Burned, cracked, broken, or blistered.	Replace defective resistors. Check for cause of burned component and repair as necessary.
Solder Connections	Cold solder or rosin joints.	Resolder joint and clean with isopropyl alcohol.
Capacitors	Damaged or leaking cases. Corroded solder on leads or terminals.	Replace defective capacitors. Clean solder connections and flush with isopropyl alcohol.
Semiconductors	Loosely inserted in sockets. Distorted pins.	Firmly seat loose semiconductors. Remove devices having distorted pins. Carefully straighten pins (as required to fit the socket), using long-nose pliers, and reinsert firmly. Ensure that straightening action does not crack the pins, causing them to break.
Wiring and Cables	Loose plugs or connectors. Burned, broken, or frayed wiring.	Firmly seat connectors. Repair or replace defective wires or cables.
Chassis	Dents, deformations, and damaged hardware.	Straighten, repair, or replace defective hardware.

INSPECTION. Inspect the internal parts of the 2247A for damage and wear, using Table 6-3 as a guide. Repair any problems found immediately. The repair method for most visible defects is obvious, but take particular care if heat-damaged components are found. Since overheating usually indicates other trouble in the instrument, the cause of overheating must be found and corrected to prevent further damage.

If any electrical component is replaced, do a Performance Check for the affected circuit and for other closely related circuits (see Section 4 for the Performance Check). If repair or replacement work is done on any of the power supplies, do a complete Performance Check and, if so indicated, an instrument readjustment (see Section 5 for Adjustment Procedure).



To prevent damage from electrical arcing, ensure that circuit boards and components are dry before applying power to the instrument.

CLEANING. To clean the interior, blow off dust with dry, low-pressure air (approximately 9 psi). Remove any remaining dust with a soft brush or a cloth dampened with a solution of mild detergent and water. A cotton-tipped applicator is useful for cleaning in narrow spaces and on circuit boards. If these methods do not remove all the dust or dirt, the instrument may be spray washed using a solution of 1% mild detergent and 99% water as follows:

1. Remove covers and shields to reach parts to be cleaned (see Removal and Replacement Instructions).
2. Spray wash dirty parts with the detergent-and-water solution; then use clean water to thoroughly rinse them.
3. Dry all parts with low-pressure air.

4. Dry all components and assemblies in an oven or drying compartment using low-temperature (125°F to 150°F) circulating air.

SWITCH CONTACTS. Switch contacts are permanently treated when assembled. Neither cleaning nor other preventive maintenance is necessary, unless the switch board is replaced or the switch assembly has remained disassembled for a long time.

LUBRICATION

A regular lubrication program for the instrument is not necessary. Most of the potentiometers used in this instrument are permanently sealed and generally do not require periodic lubrication. The backs of the front-panel knob guides have been lubricated when assembled and will require lubrication again only when the front-panel assembly is replaced. Rotary switches are installed with proper lubrication when assembled and will require lubrication only when the rotor is replaced.

SEMICONDUCTOR CHECKS

Periodic checks of the transistors and other semiconductors in the oscilloscope are not recommended. The best check of semiconductor performance is actual operation in the instrument.

PERIODIC READJUSTMENT

To ensure accurate measurements, check the performance of this instrument every 2000 hours of operation or, if used infrequently, once each year. If you replace any components, it may be necessary to readjust the affected circuits.

Complete performance check instructions are given in Section 4 of this manual; adjustment instructions are given in Section 5. The Performance Check Procedure can be helpful in localizing certain troubles in the instrument. In some cases, minor problems may be revealed or corrected by readjustment. If only a partial adjustment is performed, see Table 5-1 (the interaction chart) for possible adjustment interaction with other circuits.

TROUBLESHOOTING

INTRODUCTION

Preventive maintenance done on a regular basis should reveal most potential problems before an instrument malfunctions. However, should troubleshooting be needed, the following information will help to locate a fault. In addition, the Theory of Operation and the Diagrams sections of this manual may be helpful while troubleshooting.

TROUBLESHOOTING AIDS

Diagnostic Firmware

This instrument contains built-in diagnostic routines that can aid in localizing failures. An automatic power-up self test checks the system RAM and ROM and readout interface circuitry. If a failure is detected, this information is presented in either of two ways: a flashing code display on the Trigger LEDs or, if the instrument is capable of presenting a readout, error messages in the crt display. In addition to the power-on testing, various diagnostic routines can be run from the service mode using the SERVICE MENU. (See Internal Testing Capabilities in this subsection for the details.)

Schematic Diagrams

Complete schematic diagrams are located on tabbed foldout pages in the Diagrams section. Portions of circuitry mounted on each circuit board are enclosed by heavy black lines. The assembly number and name(s) of the circuit(s) are shown near the top or the bottom edge of each diagram.

Functional blocks on schematic diagrams are outlined with a wide gray line. Components within the outlined area perform the function designated by the block label. The Theory of Operation uses these functional block names when describing circuit operation as an aid in cross-referencing between the circuit description and the schematic diagrams.

Component numbers and electrical values of components in this instrument are shown on the schematic diagrams. Refer to the first page of the Diagrams section for the reference designators and symbols used to identify components. Important voltages and waveform reference numbers (enclosed in hexagonal-shaped boxes) are also shown on each diagram. Waveform

illustrations are located adjacent to their respective schematic diagram.

Circuit Board Illustrations

Circuit board illustrations showing the physical location of each component are provided for use with the schematic diagrams. Each board illustration is found in the Diagrams section on the back of a foldout page, preceding the first related schematic diagram.

The locations of waveform test points are marked on the circuit board illustrations with hexagonal outlined numbers corresponding to the waveform numbers on both the schematic diagram and the waveform illustrations.

Circuit Board Locations

The location of a circuit board within the instrument is shown on the foldout page along with the circuit board illustration.

Circuit Board Interconnections

A circuit board interconnection diagram (schematic Diagram 17) is provided in the Diagrams section to aid in tracing a signal path or power source between boards. All wire, plug, and jack numbers are shown along with their associated wire or pin numbers and signal names.

Power Distribution

Two power distribution diagrams (schematic Diagrams 15 and 16) are provided to aid in troubleshooting power supply problems. These diagrams show the components that the various voltages are applied to and the jumper connections and decoupling components used to apply the power to those circuits. Excessive loading on a power supply by a circuit fault may be isolated by disconnecting the appropriate jumpers.

Grid Coordinate System

Each schematic diagram and circuit board illustration has a grid border along its left and top edges. A table located next to each schematic diagram lists the grid coordinates of each component shown in that diagram. To aid in physically locating components on the circuit board, the table also lists the grid coordinates of each component in the circuit board illustration.

Near each circuit board illustration is an alphanumeric listing of all components mounted on that board. The second column in each listing identifies the schematic diagram in which each component can be found. These component–locator tables are especially useful when more than one schematic diagram is associated with a particular circuit board.

Component Color Coding

Information regarding color codes and markings of resistors is located in the color–coding illustration (Figure 9–1) at the beginning of the Diagrams section.

RESISTOR COLOR CODE. Resistors used in this instrument are carbon–film, composition, or precision metal–film types. They are usually color coded with the EIA color code; however, some metal–film type resistors may have the value printed on the body. The color code is interpreted starting with the stripe nearest to one end of the resistor. Composition resistors have four stripes; these represent two significant digits, a multiplier, and a tolerance value. Metal–film resistors have five stripes representing three significant digits, a multiplier, and a tolerance value.

CAPACITOR MARKINGS. Capacitance values of common plastic capacitors and small electrolytics are marked on the side of the capacitor body. Small, machine–insertable capacitors are numerically coded in picofarads. The first two numbers are the significant digits and the third number (if a three–number code) is the number of zeros following the digits. When there are two numbers separated by the letter “R”, the two numbers are the significant digits; the letter marks the radix (decimal point). Some examples of this type of capacitor coding are as follows:

- 475 = 47 00000 pF = 4.7 μF
- 472 = 47 00 pF = .0047 μF
- 471 = 47 0 pF
- 470 = 47 pF
- 4R7 = 4.7 pF

The code numbers are difficult to locate and read on installed parts. Capacitor values may be found by referencing the circuit designation number in the “Replaceable Electrical Parts” list.

DIODE COLOR CODE. The cathode end of each glass–encased diode is indicated by either a stripe, a series of stripes, or a dot. For most diodes marked with a series of stripes, the color combination of the stripes

identifies three digits of the Tektronix Part Number, using the resistor color–code system. The cathode and anode ends of a metal–encased diode may be identified by the diode symbol marked on its body.

Semiconductor Lead Configurations

Figure 9–2 in the Diagrams section shows the lead configurations for semiconductor devices used in the instrument. These lead configurations and case styles are typical of those used at completion of the instrument design. Vendor changes and performance improvement changes may result in changes of case styles or lead configurations. If the device in question does not appear to match the configuration shown in Figure 9–2, examine the associated circuitry or consult a manufacturer’s data sheet.

Multipin Connections

This instrument uses two types of cable connectors. The main type is an etched–circuit ribbon cable with pin connectors crimped directly to the end of the cable. The number one pin is indicated by a mark on the ribbon cable. The other type of connector is a plastic holder containing connectors crimped to the ends of individual wires. Orientation, where important, is indicated by a triangle (arrow).

TROUBLESHOOTING EQUIPMENT

The equipment listed in Table 4–1 of this manual, or equivalent equipment, may be useful when troubleshooting this instrument.

TROUBLESHOOTING TECHNIQUES

The following procedure is arranged in an order that enables checking simple trouble possibilities before requiring more extensive troubleshooting. The first two steps use diagnostic routines built into the operating system of the instrument.

The next four procedures are check steps that ensure proper control settings, connections, operation, and adjustment. If the trouble is not located by these checks, the remaining steps will aid in locating the defective component. When the defective component is located, replace it by using the appropriate replacement procedure given under Corrective Maintenance in this section.



Before using any test equipment to make measurements on static-sensitive, current-sensitive, or voltage-sensitive components or assemblies, ensure that any voltage or current supplied by the test equipment does not exceed the limits of the component to be tested.

1. Power-up Tests

When the instrument power is applied, self tests are automatically run to verify proper operation of the system RAM and ROM and readout interface circuitry. If the power-up test fails, failure codes appear in the Trigger Mode LEDs to identify the general location of the fault. (See Power-Up Testing later in this section for failure-code information.)

2. Diagnostic Routines

Various diagnostic routines can be run from the service mode. The routines can be run at any time by displaying the SERVICE MENU and selecting the desired item from the menu using front panel pushbuttons.

Entry into the SERVICE MENU and its uses are explained in the Diagnostic Routines discussion later in this section.

3. Check Control Settings

Incorrect control settings can give a false indication of instrument malfunction. If there is any question about the correct function or operation of any control, refer to the Operating Information in the 2247A Operators Manual.

4. Check Associated Equipment

Before proceeding, ensure that any equipment used with the 2247A is operating correctly. Verify that input signals are properly connected and that the interconnecting cables are not defective. Check that the ac-power-source voltage to all equipment is correct.

5. Visual Check

WARNING

To avoid electrical shock, disconnect the instrument from the ac power source before making a visual inspection of the internal circuitry.

Look for broken connections or wires, damaged components, semiconductors not firmly mounted, damaged circuit boards, or other clues to the cause of an instrument malfunction.

6. Check Instrument Performance and Adjustment

Check the performance of either those circuits where you suspect trouble or the entire instrument. An apparent trouble may be the result of misadjustment. The complete performance check is given in Section 4 of this manual, and adjustment instructions are given in Section 5.

7. Isolate Trouble to a Circuit

To isolate problems, use any symptoms noticed when checking the instrument's operation to help localize the trouble to a particular circuit. For example, if the vertical deflection is incorrect on all channels, the problem is most likely from the delay line driver to the vertical output; if deflection is bad only on one channel, the problem is from the attenuator of that channel to the input of the delay line driver. The detailed block diagram shown in the foldout section may be used as an aid in determining signal flow and control line dependency for correct circuit operation. Refer to the troubleshooting hints given in Table 6-6 for diagnostic routine failures. Troubleshooting hints by diagram are given immediately following Table 6-6, and Table 6-9 may be used to aid in locating a problem in the measurement system.

8. Check Power Supplies

WARNING

For safety reasons, an isolation transformer must be used between the ac power main and the instrument's ac power input whenever troubleshooting is done with the cabinet removed. This is especially important when working in the Preregulator and Inverter Power Supply sections of the instrument.

When trouble symptoms appear in more than one circuit, first check the power supplies; then check the affected circuits by taking voltage and waveform readings. Check first for the correct output voltage of each individual supply. These voltages are measured between J1204 (interface connector between power supply and main board) and ground (J1204 pin 4 or 8). See the associated circuit board illustration and Table 6-4.

Voltages levels may be measured either with a DMM or with an oscilloscope. Voltage ripple amplitudes must be measured using an oscilloscope. Use a 1X probe with as short a ground lead as possible to minimize stray pickup.

NOTE

Use 20 MHz bandwidth limiting on the test oscilloscope. A higher bandwidth may produce higher observed ripple levels.

If the power-supply voltages and ripple are within the listed ranges in Table 6-4, the supply can be assumed to be working correctly. If they are outside the range, the supply may be either misadjusted, operating incorrectly, or excessively loaded. The power supply adjustment procedure is given in the Power Supply, Display, and Z-Axis subsection of Section 5 (the Adjustment Procedure).

A defective component elsewhere in the instrument can create the appearance of a power-supply problem and

may also affect the operation of other circuits. Use the power distribution diagrams (schematic Diagrams 15 and 16 in the foldouts) to aid in localizing a loading problem to a particular circuit.

9. Check Circuit Board Interconnections

After the trouble has been isolated to a particular circuit, again check for loose or broken connections, improperly seated semiconductors, and heat-damaged components.

10. Check Voltages and Waveforms

Often the defective component can be located by checking circuit voltages or waveforms. Typical voltages are listed on the schematic diagrams. Waveforms indicated on the schematic diagrams by hexagonal-outlined numbers are shown adjacent to the diagrams. Waveform test points are shown in the circuit board illustrations.

NOTE

Voltages and waveforms indicated on the schematic diagrams are not absolute and may vary slightly between instruments. To establish operating conditions similar to those used to obtain these readings, see the Voltage and Waveform Setup Conditions preceding the waveform illustrations in the Diagrams section.

**Table 6-4
Power Supply Voltage and Ripple Limits**

Nominal Supply Voltage	Test Point (+ lead)	Limits (0°C to 50°C)		P-P Ripple ^a	
		Min	Max	60-150 Hz	20-40 kHz
+130	J1204-11	+127	+135	70 mV	70 mV
+58	J1204-10	+55.7	+59.2	40 mV	120 mV
+15	J1204-7	+14.6	+15.6	8 mV	4 mV
+7.5	J1204-8	+7.4	+7.6	8 mV	4 mV
+5.0	J1204-1,2	+5.0	+5.3	30 mV	20 mV
-5.0	J1204-5	-5.1	-5.4	4 mV	4 mV
-7.5	J1204-9	-7.4	-7.8	4 mV	4 mV
-15 unreg	J1204-6	-15.5	-16.6	10 mV	100 mV

^aAt rated load.

Note the recommended test equipment, front-panel control settings, voltage and waveform conditions, and cable-connection instructions. Any special control settings required to obtain a given waveform are noted under the waveform illustration. Volts/Div and Sec/Div settings of the test oscilloscope for a waveform are indicated in the waveform illustration.

11. Check Individual Components

WARNING

To avoid electric shock, always disconnect the instrument from the ac power source before removing or replacing components.

The following procedures describe methods of checking individual components. Two-lead components that are soldered in place are most accurately checked by first disconnecting one end from the circuit board. This isolates the measurement from the effects of the surrounding circuitry. See Figure 9-1 for resistor value identification and Figure 9-2 for semiconductor lead configurations. Cross check the circuit component number with the Electrical Parts List for capacitor values.

CAUTION

When checking semiconductors, observe the static-sensitivity precautions given at the beginning of this section.

TRANSISTORS. A good check of a transistor is actual performance under operating conditions. A transistor can most effectively be checked by substituting a known-good component. However, be sure that circuit conditions are not such that a replacement transistor might also be damaged. If substitute transistors are not available, use a dynamic-type transistor checker for testing. Static-type transistor checkers are not recommended, since they do not check operation under simulated operating conditions.

When troubleshooting transistors in the circuit with a voltmeter, measure both the emitter-to-base and emitter-to-collector voltages to determine whether they are consistent with normal circuit voltages. Voltages across a transistor may vary with the type of device and its circuit function.

Some of these voltages are predictable. The emitter-to-base voltage for a conducting silicon transistor will normally range from 0.6 V to 0.8 V. The emitter-to-collector voltage for a saturated transistor is about 0.2 V. Because these values are small, the best way to check them is by connecting a sensitive voltmeter across the junction rather than comparing two voltages taken with respect to ground. If the former method is used, both leads of the voltmeter must be isolated from ground.

If voltage values measured are less than those just given, either the device is shorted or no current is flowing in the external circuit. If values exceed the emitter-to-base values given, either the junction is reverse biased or the device is defective. Voltages exceeding those given for typical emitter-to-collector values could indicate either a nonsaturated device operating normally or a defective (open-circuited) transistor. If the device is conducting, voltage will be developed across the resistors in series with it; if open, no voltage will be developed across the resistors unless current is being supplied by a parallel path.

CAUTION

When checking emitter-to-base junctions, do not use an ohmmeter range that has a high internal current. High current may damage the transistor. Reverse biasing the emitter-to-base junction with a high current may degrade the current-transfer ratio (Beta) of the transistor.

A transistor emitter-to-base junction also can be checked for an open or shorted condition by measuring the resistance between terminals with an ohmmeter set to a range having a low internal source current, such as the R X 1 k Ω range. The junction resistance should be very high in one direction and much lower when the meter leads are reversed.

When troubleshooting a field-effect transistor (FET), the voltage across its elements can be checked in the same manner as previously described for other transistors. However, remember that in the normal depletion mode of operation, the gate-to-source junction is reverse biased; in the enhanced mode, the junction is forward biased.

INTEGRATED CIRCUITS. An integrated circuit (IC) can be checked with a voltmeter, test oscilloscope, or by direct substitution. A good understanding of circuit operation is essential when troubleshooting a circuit having IC components. Use care when checking

voltages and waveforms around the IC so that adjacent leads are not shorted together. An IC test clip provides a convenient means of clipping a test probe to an IC.



When checking a diode, do not use an ohmmeter scale that has a high internal current. High current may damage a diode. Checks on diodes can be performed in much the same manner as those on transistor emitter-to-base junctions.

DIODES. A diode can be checked for either an open or a shorted condition by measuring the resistance between terminals with an ohmmeter set to a range having a low internal source current, such as the R X 1 kΩ range. The diode resistance should be very high in one direction and much lower when the meter leads are reversed.

Silicon diodes should have 0.6 V to 0.8 V across their junctions when conducting; Schottky diodes about 0.2 V to 0.4 V. Higher readings indicate that they are either reverse biased or defective, depending on polarity.

RESISTORS. Check resistors with an ohmmeter. Refer to the Replaceable Electrical Parts list for the tolerances of resistors used in this instrument. A resistor normally does not require replacement unless its measured value varies widely from its specified value and tolerance.

INDUCTORS. Check for open inductors by checking continuity with an ohmmeter. Shorted or partially shorted inductors can usually be found by checking the waveform response when high-frequency signals are passed through the circuit.

CAPACITORS. A leaky or shorted capacitor can best be detected by checking resistance with an ohmmeter set to one of the highest ranges. Do not exceed the voltage rating of the capacitor. The resistance reading should be high after the capacitor is charged to the output voltage of the ohmmeter. An open capacitor can be detected with a capacitance meter or by checking whether the capacitor passes ac signals.

12. Repair and Adjust the Circuit

If any defective parts are located, follow the replacement procedures given under Corrective Maintenance in this section. After any electrical component has been

replaced, the performance of that circuit and any other closely related circuit should be checked. Since the power supplies affect all circuits, performance of the entire instrument should be checked if work has been done on the power supplies. Readjustment of the affected circuitry may be necessary. Refer to the Performance Check Procedure and the Adjustment Procedure, (sections 4 and 5) and to Table 5-1 (Adjustment Interactions).

INTERNAL TESTING CAPABILITIES

The diagnostics built into the 2247A permit the technician to test much of the digital circuitry and the digital-to-analog interface. The following text describes the testing capabilities of the Measurement Processor and the firmware controlled circuitry.

Power-Up Testing

The systems shown in Figure 6-1 are tested at power-on. Failure codes appear in the Trigger MODE LEDs, with ON being shown as “x” and OFF as “o” in the figure. In the event of a display failure where error message cannot be displayed on the crt, the codes indicate a failure area to begin troubleshooting.

Tests Run	Failure Code (seen on the Trigger LEDES)					
	AUTO LEVEL	AUTO	NORM	TV LINE	TV FIELD	SGL SEQ
System RAM	X	0	0	0	0	0
System ROM	0	X	0	0	0	0
Readout Interface	0	0	X	0	0	0
DAC Subsystem	X	0	X	0	0	0

6555-22

Figure 6-1. Power-on test failure codes.

Power-up tests performed are:

1. RAM diagnostics—failures indicated by flashing AUTO LEVEL lamp. Three diagnostics are run on all locations in the RAM:
 - a. Store and read 00.
 - b. Store and read FF.
 - c. Store and read pseudo-random pattern.

2. ROM diagnostics—failures indicated by flashing AUTO lamp. Tests all of ROM, except for ROM header. Runs proprietary version of CRCC test.
3. Readout interface diagnostics—failures indicated by flashing NORM lamp. Performs a marching-one test around the loop from D7–D0 to R7–R0 and back.
4. DAC interface diagnostics—failures indicated by flashing AUTO LEVEL and NORM lamps. Performs three tests:
 - a. Checks that $\overline{\text{DAC INTR}}$ is high after power-up.
 - b. Checks that $\overline{\text{DAC INTR}}$ goes low after a byte is sent from the Measurement Processor.
 - c. Checks that $\overline{\text{DAC INTR}}$ goes high again after the DAC Processor reads the byte sent from the Measurement Processor.

SERVICE MODE

The service mode driver menu is accessed by pressing the top and the bottom menu-item buttons at the same time. The main SERVICE MENU is shown in Figure 6-2. Each service menu display has two parts; the part to the left is the service menu, and the part to the right is the modifier menu.

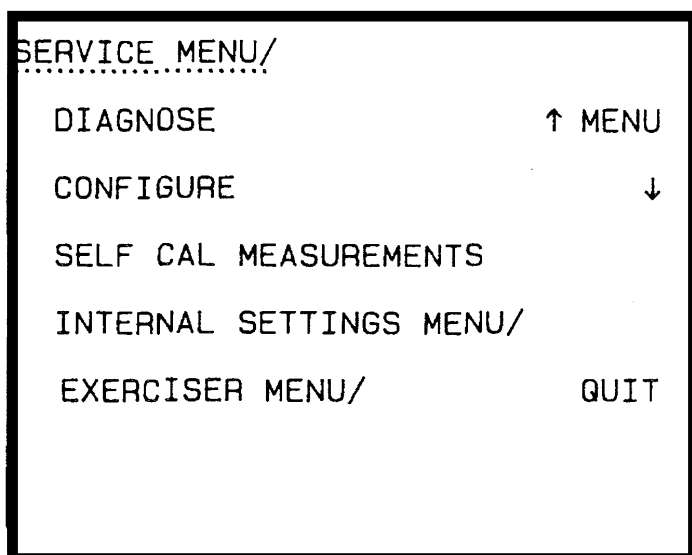

6555-23

Figure 6-2. Main SERVICE MENU.

Each service menu has a title and a number of selectable items in the menu. The title appears in the top line of the crt display, and the selectable items appear under the title, indented (see Figure 6-2). Menu choices that are names of sub-menus have a following slash (/), and when one is underlined, the word "SELECT" appears in the modifier menu list. When a choice with sub-menus is selected, the sub-menu choices are displayed on the left side of the screen with the name of the selected sub-menu displayed in the top line.

A menu choice that has no following slash is an executable service routine. The routine may be run by underlining it and pressing the menu button next to the RUN label that appears in the modifier menu list. Executable servicing selections are: diagnostics that return either a pass message or a fail message along with service data; one-shot exercisers that carry out some service and immediately return to the menu; or regular exercisers that carry out a service while continuously displaying service data.

An underlined service-menu choice is available for selection. To select a menu item, use the buttons next to the up-arrow and down-arrow symbols to move the underline up or down in the SERVICE MENU. When the underline is below the sub-menu title, pressing the menu button next to up-arrow MENU label returns to the preceding menu containing that sub-menu (an up-menu operation).

Pressing the QUIT selection at any time the choice is displayed will cause the scope to return to normal oscilloscope mode. If a service routine is operating that has an END menu selection displayed, pressing the button next to END exits the routine and returns to the selection menu (where QUIT is displayed). Routines that run once, return to the selection menu when finished. Pressing the CLEAR DISPLAY button while any menu is being displayed will cause the scope to return to normal oscilloscope mode.

The diagnostic tests in the SERVICE MENU may be run with a conditional setting that determines how many times the routine is done. The conditional MODE setting menu choice appears in the modifier menu when the DIAGNOSE choice in the SERVICE MENU is underlined (see Figure 6-3). One of the following mode types will be displayed:

ONCE, CONTINUOUS, UNTIL PASS, or UNTIL FAIL

Change the mode type displayed in the bottom line by pressing the MODE button. When ONCE is the mode, the diagnostic is run once, and the result is displayed. When CONTINUOUS is the mode, the diagnostics are run continuously. When UNTIL PASS is the mode, the diagnostics are run until they pass. When UNTIL FAIL is the mode, the diagnostics are run until they fail. In order to stop a diagnostic that is looping in the CONTINUOUS, UNTIL PASS, or UNTIL FAIL mode, press the HALT button. The diagnostic will stop and display the current status. When the status is displayed, press END to return to the SERVICE MENU choices.

```

SERVICE MENU/
DIAGNOSE.           ↑
CONFIGURE           ↓
SELF CAL MEASUREMENTS  RUN
INTERNAL SETTINGS MENU/
EXERCISER MENU/     QUIT
MODE:
ONCE
    
```

(6555-24)6367-36

Figure 6-3. SERVICE MENU with DIAGNOSE choice selected.

Service Routines

Descriptions of the available service routines are given in Table 6-5. The complete SERVICE MENU has this structure:

```

SERVICE MENU/
DIAGNOSE
CONFIGURE
SELF CAL MEASUREMENTS
INTERNAL SETTINGS MENU/
MAKE FACTORY SETTINGS
LOAD STORE/RECALL SETUPS
ADJUST VERTICAL OUTPUT
EXERCISER MENU/
FRONT PANEL MENU/
EXERCISE POTS
EXERCISE LEDS
EXERCISE SWITCHES
PROC BOARD MENU/
A TO D MENU/
EXERCISE DACS
EXERCISE PORTS
READOUT MENU/
SHOW READOUT ROM HEADER
EXERCISE RO INTERFACE
SHOW SYSTEM ROM HEADER
EXERCISE TIME REF
SHOW AUTO RESTARTS
MAIN BOARD MENU/
SHIFT REGISTER MENU/
EXERCISE SR 0
EXERCISE SR 1
EXERCISE SR 2
EXERCISE VOLT REF
    
```

Table 6-5
SERVICE MENU Selections

Menu Item	Action
DIAGNOSE	<p>Runs all diagnostics in sequence, stopping at the first failed diagnostic. (See Table 6-6 for a diagnostic test failure troubleshooting guide.) Diagnostics are:</p> <ul style="list-style-type: none"> RO (readout) INTERFACE ROM RAM SLIC CONTROL REG SHIFT REGISTERS (in SR2, SR0, SR1, SR3 order) DAC Triggers Counter/Timer
CONFIGURE	<p>Configures the scope-mode operation of the instrument according to the users' wishes. Configuration is done by answering yes/no questions. The questions are:</p> <p>KEEP MENU ON WHEN MEAS SELECTED? The menu remains displayed after a measurement function has been selected from one of the Measurements menus.</p> <p align="center">NOTE</p> <p><i>The setting of KEEP MENU ON WHEN MEAS SELECTED does not affect the STORE/RECALL SETUP menu that is displayed when the scope is configured for RECALL ONLY.</i></p> <p>RECALL ONLY? (IN STORE/RECALL) Selecting YES displays the Recall Only menu when the STORE/RECALL SETUP button is pressed. From the Recall Only menu you can easily step through all of the stored front-panel setups.</p> <p>Selecting NO displays the Store/Recall menu when the STORE/RECALL SETUP button is pressed. From the Store/Recall Setup menu you can store, edit, and recall front-panel setups.</p> <p>MENU ON WHEN S/R SELECTED? Selecting YES causes the STORE/RECALL menu to remain displayed after a store or recall function has been selected.</p> <p>KEEP READOUT ON IN SGL SEQ? Selecting YES causes the readout to be on constantly when in SGL SEQ trigger mode.</p> <p>Selecting NO causes the readout to flash on for a brief period after the signal display sequence has finished.</p> <p>INITIALIZE TIME CURSORS/DELAYS? If YES is selected, under certain conditions (see Operators Manual) the cursors or delays will be initialized appropriate to the measurement mode.</p> <p>Cursors and delays may remain unchanged if there is no A trigger or the trigger source channel's signal has a repetition rate slower than 20 Hz or faster than 100 MHz. Then a question mark may appear before the value and remain until one of the CURSORS/TIME POSITION controls is moved.</p> <p>PRESET TV TRIG SLOPE FOR -SYNC? Selecting YES will cause the trigger slopes to preset to - (minus) when TV trig mode is selected. If NO is selected, a second question is presented:</p> <p>PRESET TV TRIG SLOPE FOR + SYNC? Selecting YES will cause the trigger slopes to preset to + when TV trig mode is selected. If NO is selected, the scope will not use a preset slope when a TV trig mode is selected.</p>

Table 6-5 (cont)



Menu Item	Action																														
SELF CAL MEASUREMENTS	Self characterizes the gain and offset errors in the vertical system and time base so that they may be compensated for in the measurements. This should be run only after instrument is warmed up properly, although if desired, it can be used to compensate for an unusual operating temperature.																														
MAKE FACTORY SETTINGS	<p>Resets the front panel settings to those shipped with the instrument. Used to produce a known setup condition. The following is a partial list of settings:</p> <table border="0"> <tr> <td>Vertical MODE</td> <td>CH 1 AND CH 2</td> </tr> <tr> <td>CH 1/CH 2 COUPLING</td> <td>DC</td> </tr> <tr> <td>CH 1, 2, 3, 4 VOLTS/DIV</td> <td>0.1 V</td> </tr> <tr> <td>CH 2 INVERT</td> <td>OFF</td> </tr> <tr> <td>SCOPE BW</td> <td>OFF</td> </tr> <tr> <td>HORIZONTAL MODE</td> <td>A</td> </tr> <tr> <td>A SEC/DIV</td> <td>0.1 ms</td> </tr> <tr> <td>B SEC/DIV</td> <td>1 μs</td> </tr> <tr> <td>A/B Trigger SLOPE</td> <td></td> </tr> <tr> <td>A/B Trigger SELECT</td> <td>A</td> </tr> <tr> <td>A Trigger MODE</td> <td>AUTO LEVEL</td> </tr> <tr> <td>B Trigger MODE</td> <td>RUNS AFTER</td> </tr> <tr> <td>A/B Trigger SOURCE</td> <td>CH 1</td> </tr> <tr> <td>A/B Trigger COUPLING</td> <td>DC</td> </tr> <tr> <td>MEASUREMENTS</td> <td>OFF</td> </tr> </table>	Vertical MODE	CH 1 AND CH 2	CH 1/CH 2 COUPLING	DC	CH 1, 2, 3, 4 VOLTS/DIV	0.1 V	CH 2 INVERT	OFF	SCOPE BW	OFF	HORIZONTAL MODE	A	A SEC/DIV	0.1 ms	B SEC/DIV	1 μ s	A/B Trigger SLOPE		A/B Trigger SELECT	A	A Trigger MODE	AUTO LEVEL	B Trigger MODE	RUNS AFTER	A/B Trigger SOURCE	CH 1	A/B Trigger COUPLING	DC	MEASUREMENTS	OFF
Vertical MODE	CH 1 AND CH 2																														
CH 1/CH 2 COUPLING	DC																														
CH 1, 2, 3, 4 VOLTS/DIV	0.1 V																														
CH 2 INVERT	OFF																														
SCOPE BW	OFF																														
HORIZONTAL MODE	A																														
A SEC/DIV	0.1 ms																														
B SEC/DIV	1 μ s																														
A/B Trigger SLOPE																															
A/B Trigger SELECT	A																														
A Trigger MODE	AUTO LEVEL																														
B Trigger MODE	RUNS AFTER																														
A/B Trigger SOURCE	CH 1																														
A/B Trigger COUPLING	DC																														
MEASUREMENTS	OFF																														
LOAD STORE/RECALL SETUPS	Loads eight factory front-panel setups into the Store/Recall memory. The setups are stored in memory locations 01 through 08, and all previously stored setups in locations 01 through 20 will be deleted. When you select this item, a message will be displayed that will give you the choice to continue or not continue with the loading of the factory setups. Don't select YES unless you are sure that you want to delete all of your previously stored setups.																														
ADJUST VERTICAL OUTPUT	Used to adjust the vertical output gain and centering (see Adjustment Procedure in Section 5).																														
EXERCISE POTS	Shows the name of the latest digitized potentiometer moved, along with its hexadecimal value (from FF to 00). Starts by showing the HORIZ POSITION and its value until another pot is adjusted. The FOCUS and SCALE ILLUMINATION controls are not digitized and therefore are not checked with this exercise. Pressing END exits the exerciser.																														
EXERCISE LEDES	Uses the delay control to check for adjacent-row or adjacent-column shorts in the front panel board and for inoperative LEDs. The exercise will display the circuit number and illuminate each LED as the control is rotated. Circuit numbers DS2016, DS2017, DS2018, DS2019, DS2024, DS2040, and DS2049 do not correspond to any LEDs on the front panel. Pressing END exits the exerciser.																														
EXERCISE SWITCHES	Shows the circuit number of the latest momentary-contact button pressed, or the name and position of the latest rotary switch turned. Pressing END exits the exerciser program and pressing CLEAR MEAS'MT will terminate the Service Program.																														

Table 6-5 (cont)

Menu Item	Action																								
EXERCISE DACS	Attaches the DAC (U2302, Diagram 11) to a single sample-and-hold channel (through U2303), and outputs a sawtooth waveform to that channel. Select the channel by pressing STEP. This exerciser may be used to trace a sample-and-hold value through the system, with the DAC system operating in a non-multiplexed mode. Pressing END exits the exerciser.																								
EXERCISE PORTS	Continuously does analog-to-digital conversion on a single A-to-D port. Select the port by pressing STEP. The exerciser may be used to trace a single potentiometer wiper value or probe code value through the system by operating the A-to-D converter in a non-multiplexed mode. Pressing END exits the exerciser.																								
SHOW READOUT ROM HEADER	Shows the Readout ROM part number (U2408, Diagram 9) and its expected and actual checksum.																								
EXERCISE RO INTERFACE	Continuously echos a marching-bit value across the readout interface. This exerciser may be used to check the integrity of the Measurement-Processor-to-Readout-Processor communication system. Pressing END exits the exerciser.																								
SHOW SYSTEM ROM HEADER	Shows the system ROM part numbers (U2519, Diagram 8) and checksums of the installed firmware version.																								
EXERCISE TIME REF	<p>Steps through the timing frequencies used to characterize the horizontal timing accuracy. Calibration periods are shown in the following table.</p> <table border="1" data-bbox="674 1122 1088 1518"> <thead> <tr> <th data-bbox="678 1128 806 1160">Time</th> <th data-bbox="905 1128 1083 1160">Test Period</th> </tr> </thead> <tbody> <tr> <td data-bbox="700 1178 784 1205">.5 μs</td> <td data-bbox="981 1178 1042 1205">2 μs</td> </tr> <tr> <td data-bbox="700 1211 784 1238">5 μs</td> <td data-bbox="964 1211 1042 1238">32 μs</td> </tr> <tr> <td data-bbox="700 1245 784 1272">10 μs</td> <td data-bbox="964 1245 1042 1272">64 μs</td> </tr> <tr> <td data-bbox="700 1279 784 1305">20 μs</td> <td data-bbox="948 1279 1042 1305">128 μs</td> </tr> <tr> <td data-bbox="700 1312 784 1339">50 μs</td> <td data-bbox="948 1312 1042 1339">256 μs</td> </tr> <tr> <td data-bbox="700 1346 784 1373">.1 ms</td> <td data-bbox="948 1346 1042 1373">512 μs</td> </tr> <tr> <td data-bbox="700 1379 784 1406">.2 ms</td> <td data-bbox="931 1379 1042 1406">1.024 ms</td> </tr> <tr> <td data-bbox="700 1413 784 1440">.5 ms</td> <td data-bbox="931 1413 1042 1440">2.048 ms</td> </tr> <tr> <td data-bbox="700 1447 784 1473">1 ms</td> <td data-bbox="931 1447 1042 1473">4.096 ms</td> </tr> <tr> <td data-bbox="700 1480 784 1507">2 ms</td> <td data-bbox="931 1480 1042 1507">8.192 ms</td> </tr> <tr> <td data-bbox="700 1514 784 1541">5 ms</td> <td data-bbox="915 1514 1042 1541">32.768 ms</td> </tr> </tbody> </table>	Time	Test Period	.5 μ s	2 μ s	5 μ s	32 μ s	10 μ s	64 μ s	20 μ s	128 μ s	50 μ s	256 μ s	.1 ms	512 μ s	.2 ms	1.024 ms	.5 ms	2.048 ms	1 ms	4.096 ms	2 ms	8.192 ms	5 ms	32.768 ms
Time	Test Period																								
.5 μ s	2 μ s																								
5 μ s	32 μ s																								
10 μ s	64 μ s																								
20 μ s	128 μ s																								
50 μ s	256 μ s																								
.1 ms	512 μ s																								
.2 ms	1.024 ms																								
.5 ms	2.048 ms																								
1 ms	4.096 ms																								
2 ms	8.192 ms																								
5 ms	32.768 ms																								
SHOW AUTO RESTARTS	Shows the address being executed if a software error occurs that causes execution out of normal memory space. This is for factory use only and is of no use in field servicing of the instrument. If an AUTO RESTART is ever seen, record the address displayed and report it to a service center; the error address is cleared from memory when SHOW AUTO RESTARTS is exited.																								
EXERCISE SR 0	Shifts alternate zeros and ones through Shift Register 0 (U171, U172, and U173, Diagram 1). This shift register sets Attenuator and Input Coupling relay positions and Vertical Preamplifier gain settings.																								
EXERCISE SR 1	Shifts alternate zeros and ones through Shift Register 1 (U302 and U303, Diagram 5; U1103, Diagram 3). This shift register sets sweep speeds and auxiliary trigger settings (TV Trigger, Scope Bandwidth, X10 magnification, and X-Y Mode).																								

Table 6-5 (cont)

Menu Item	Action												
EXERCISE SR 2	Shift alternate zeros and ones through Shift Register 2 (U502, Diagram 4).												
EXERCISE VOLT REF	<p data-bbox="513 488 1538 674">Steps through all settings of the Voltage Reference Generator (U931, Diagram 7) that are used to calibrate the Volts Measurement system. For each setting, Channels 1 and 2 are placed into the gain configuration (2 mV through 50 mV) that uses that setting. The voltage select lines (VOLTS CAL 2-0) may be checked for activity, and the generated VOLTS CAL SIGNAL may be measured to check its values.</p> <table border="1" data-bbox="707 703 1146 943"> <thead> <tr> <th data-bbox="712 712 860 748">VOLTS/DIV</th> <th data-bbox="987 712 1136 748">Cal voltage</th> </tr> </thead> <tbody> <tr> <td data-bbox="723 779 806 808">2 mV</td> <td data-bbox="1042 779 1136 808">10 mV</td> </tr> <tr> <td data-bbox="723 808 806 837">5 mV</td> <td data-bbox="1042 808 1136 837">25 mV</td> </tr> <tr> <td data-bbox="723 837 806 866">10 mV</td> <td data-bbox="1042 837 1136 866">50 mV</td> </tr> <tr> <td data-bbox="723 866 806 896">20 mV</td> <td data-bbox="1025 866 1136 896">100 mV</td> </tr> <tr> <td data-bbox="723 896 806 925">50 mV</td> <td data-bbox="1025 896 1136 925">250 mV</td> </tr> </tbody> </table>	VOLTS/DIV	Cal voltage	2 mV	10 mV	5 mV	25 mV	10 mV	50 mV	20 mV	100 mV	50 mV	250 mV
VOLTS/DIV	Cal voltage												
2 mV	10 mV												
5 mV	25 mV												
10 mV	50 mV												
20 mV	100 mV												
50 mV	250 mV												

DIAGNOSE Tests

The complete DIAGNOSE routine may be called up by the service technician as needed to aid in troubleshooting the instrument. Testing routines and troubleshooting information for use in the event of a failed test are given in Table 6-6.

Table 6-6
DIAGNOSE ROUTINES

Error Label	Path, Devices Tested, and Troubleshooting Actions
INTERFACE ERROR	<p>Measurement Processor to Readout Processor Communications.</p> <p>WROTE (hex number that was written, 2 characters).</p> <p>READ (hex number that was read, 2 characters).</p> <p>This test rotates a 1 through the byte on the bus lines. The difference between WROTE and READ indicates which bit is stuck.</p> <hr/> <p>Devices to troubleshoot:</p> <p>U2401, U2402, U2417C and D, and bus lines between Measurement Processor and Readout Processor.</p> <p>Check U2501 pin 29 for enabling signal to U2402, and U2400 pin 22 for clock.</p>
RAM ERROR	<p>Writes and reads test bytes from the Readout RAM (U2406).</p> <p>ADDRESS (hex address of error location, 3 characters).</p> <p>WROTE (hex data written, 2 characters).</p> <p>READ (hex data read, 2 characters).</p> <p>The difference between WROTE and READ data indicates a stuck bit.</p>
(RO RAM)	<p>PART NUM (Tektronix Part Number without dashes).</p> <p>EXPECTED CHECKSUM (hex number, 2 characters).</p> <p>ACTUAL CHECKSUM (hex number, 2 characters).</p> <p style="text-align: center;">NOTE</p> <p style="text-align: center;"><i>Readout ROM is internal to the Readout Processor, U2400; a failure of this test may mean a bad Readout Processor.</i></p>

Table 6-6 (cont)

Error Label	Path, Devices Tested, and Troubleshooting Actions
REG SR 2	<p>Front Panel Potentiometer Multiplexer data path check.</p> <p>WROTE (hex data written, 1 character).</p> <p>READ (hex data read, 1 character).</p> <p>Device Tested: U502, Diagram 4.</p> <hr/> <p>Troubleshooting checks:</p> <p>Check pin 11 for correct clock. Check pin 2 for data. Check pin 12 for multiplexer output.</p>
REG SR 0	<p>Attenuator and Preamplifier data path check.</p> <p>WROTE (hex data written, 6 characters).</p> <p>READ (hex data read, 6 characters).</p> <p>Devices Tested: U171, U172, and U173 on Diagram 1.</p> <p style="text-align: center;">NOTE</p> <p style="text-align: center;"><i>U171 and U172 have + 15 V clocks and data; U173 has + 5 V clocks and data.</i></p> <hr/> <p>Troubleshooting checks:</p> <p>Check pin 3 of each device for correct clock. Check pin 9 of each device for marching bit pattern. Attenuator relay latches are driven and a clacking sound is heard.</p>
REG SR 1	<p>Sweeps and Auxiliary Trigger data path check.</p> <p>WROTE (hex data written, 6 characters).</p> <p>READ (hex data read, 6 characters).</p> <p>Devices Tested:</p> <p>U302 and U303 on Diagram 3; U1103 on Diagram 3. Clock and data levels for U302 and U303 are + 15 V; they are + 5 V for U1103.</p> <hr/> <p>Troubleshooting checks:</p> <p>Check pin 3 of each device for correct clock. Check pin 9 of each device for marching bit pattern.</p>

Table 6-6 (cont)

Error Label	Path, Devices Tested, and Troubleshooting Actions																																	
REG SR 3	<p>Switch board data path check.</p> <p>WROTE (hex data written, 4 characters). READ (hex data read, 4 characters).</p> <p style="text-align: center;">NOTE</p> <p style="text-align: center;"><i>There is no exerciser for SR 3, but it is included in "DIAGNOSE."</i></p> <p>Devices Tested: U2001 and U2002, Diagram 10.</p> <p>Troubleshooting Checks:</p> <p>Check pin 10 for serial data in. Check pin 9 for serial data out. Check pin 2 for clock.</p>																																	
DAC ERROR 0	<p>The A-to-D system, Diagram 11, is not working correctly. Ground level was digitized out of the specified error limits.</p> <p>Devices to troubleshoot:</p> <p>U2515 and U2517, Diagram 8; U2306, U2302, U2300, U2313, and U2314, Diagram 11; U506, Diagram 7</p>																																	
(Triggers)	<p>The trigger diagnostic partially checks the Trigger SOURCE, Trigger CPLG, and Trigger SLOPE circuitry.</p> <p>Error Messages:</p> <p>TIME SIGNAL TOO SMALL AT A Trigger A Trigger circuitry failed amplitude test.</p> <p>TIME SIGNAL TOO SMALL AT B Trigger B Trigger circuitry failed amplitude test.</p> <p>NO A Trigger FOR TIME CAL SIGNAL (2 digit code, see table) Trigger never occurred.</p> <table border="1" data-bbox="750 1503 1096 1883" style="margin-left: auto; margin-right: auto;"> <thead> <tr> <th>Time Base</th> <th>Cal Signal</th> <th>Code</th> </tr> </thead> <tbody> <tr><td>128</td><td>μs</td><td>0</td></tr> <tr><td>8.192</td><td>ms</td><td>1</td></tr> <tr><td>256</td><td>μs</td><td>2</td></tr> <tr><td>4.096</td><td>ms</td><td>3</td></tr> <tr><td>2.048</td><td>ms</td><td>4</td></tr> <tr><td>512</td><td>μs</td><td>5</td></tr> <tr><td>32.768</td><td>ms</td><td>6</td></tr> <tr><td>1.024</td><td>ms</td><td>7</td></tr> <tr><td>64</td><td>μs</td><td>13</td></tr> <tr><td>32</td><td>μs</td><td>14</td></tr> </tbody> </table> <p>Check U421, U431, U1106A, and associated circuitry, Diagram 3. SLIC (Display Logic IC, U600) and FLIC (Trigger Logic IC, U602) gate outputs and level shifters, Diagram 4.</p>	Time Base	Cal Signal	Code	128	μs	0	8.192	ms	1	256	μs	2	4.096	ms	3	2.048	ms	4	512	μs	5	32.768	ms	6	1.024	ms	7	64	μs	13	32	μs	14
Time Base	Cal Signal	Code																																
128	μs	0																																
8.192	ms	1																																
256	μs	2																																
4.096	ms	3																																
2.048	ms	4																																
512	μs	5																																
32.768	ms	6																																
1.024	ms	7																																
64	μs	13																																
32	μs	14																																

Table 6-6 (cont)

Error Label	Path, Devices Tested, and Troubleshooting Actions
<p>C/T STATUS BITS WILL NOT RESET</p> <p>C CTR WILL NOT RESET</p> <p>B CTR WILL NOT RESET</p> <p>A CTR WILL NOT RESET</p>	<p>Counter/Timer checked to see if it will reset.</p> <p>Any one of these error messages indicates the C/T will not reset. The diagnostic software is unable to locate the exact failure.</p> <p>Devices to troubleshoot:</p> <p>U1902, U1905, and the resistor network that connects U1902 pins 34–39 to U1905 pins 27–32; U1903 and the resistor network at its inputs.</p> <p>To check this circuitry, exit diagnostic menu, select TOTALIZE measurement, apply a trigger signal, and check for proper signal swings.</p>
<p>C/T BUSY LINE STUCK LOW</p>	<p>Checks to see if BUSY line will go high (Counter/Timer).</p> <p>Devices to troubleshoot:</p> <p>U1905, R1941, U1903.</p> <p>Check that BUSY signal (U1905 pin 19) toggles normally during a frequency measurement. If it doesn't, U1905 or R1941 may be bad. If BUSY toggles normally, the problem may be in U1903 circuitry.</p>
<p>B CTR NOT CLOCKING PROPERLY</p>	<p>Checks to see if B counter will increment (Counter/Timer).</p> <p>Devices to troubleshoot:</p> <p>U1905 and the resistor network connected to U1905 pins 27–32.</p>
<p>UNEXPECTED VALUE READ FROM B CTR</p> <p>VALUE EXPECTED XXXXXX</p> <p>VALUE READ YYYYYY</p> <p><i>(XXXXXX = hexadecimal value expected by microprocessor)</i></p> <p><i>(YYYYYY = value actually read)</i></p>	<p>The first five stages of the C/T B counter (in U1905) are exercised first. If the B counter does not contain the right count, the error message is displayed.</p> <p>Next, the microprocessor checks the rest of the B counter (in U1902) and displays the error message if an error is found.</p> <p>Devices to troubleshoot:</p> <p>If the XXXXXX value is less than 111120 (hexadecimal), the problem is most likely in U1905 or the U1903 circuitry. Select TOTALIZE measurement, apply a trigger signal, and trace U1905 output pins 11–14 on through U1903.</p> <p>If the XXXXXX value is 111120 (hexadecimal) or higher, the problem is most likely in U1902, or else U1904 and its input resistor network are not passing BOUT (U1905 pin 4) correctly to U1902 pin 28.</p>

Table 6-6 (cont)

Error Label	Path, Devices Tested, and Troubleshooting Actions
B CTR OVERFLOW NOT DETECTABLE	Checks to see if B counter overflow flag will go high (Counter/Timer).
	Devices to troubleshoot: U1902. The problem must be in U1902 to get this error message.
C/T BUSY LINE STUCK HIGH	Checks to see if BUSY line will go low (Counter/Timer).
	Devices to troubleshoot: U1905, R1941, and U1903 circuitry. Make sure that the BUSY signal (U1905 pin 19) toggles normally during a frequency measurement. If it doesn't, U1905 or R1941 may be bad. If BUSY toggles normally, the problem may be in the U1903 circuitry.
C CTR NOT CLOCKING PROPERLY	Checks to see if C counter will increment (Counter/Timer).
	Devices to troubleshoot: U1905, U1902, and R1904 circuitry. Make sure that U1902 pin 27 toggles properly during a frequency measurement.
UNEXPECTED VALUE READ FROM C CTR VALUE EXPECTED XXXX VALUE READ YYYY	Checks the rest of the C counter (Counter/Timer).
	Devices to troubleshoot: U1902, U1904 and its input resistor network. The most likely problem is that U1902 is bad, or that U1904 and its input resistor network are not passing COUT (U1905 pin 2) correctly to U1902 pin 27.
C CTR OVERFLOW NOT DETECTABLE	Checks to see if C counter overflow flag will go high (Counter/Timer).
	Devices to troubleshoot: U1902. The problem must be in U1902 to get this error message.
A CTR FAULTY OR OSC BAD A = XXXXXX	Checks to see if A count is within proper range (Counter/Timer). C/T hardware is set for a period measurement, the measurement is started, and when the A counter is nearly full, the Measurement Processor checks range. If the A count is outside the range of 4000000 to 12000000 (decimal), the error message is displayed.
	Components to check: 10 MHz oscillator circuit and U1905 circuitry (Counter/Timer). Phase-locked-loop is either inoperative or oscillating far below normal frequency range, or the 10 MHz reference oscillator is faulty. If the A count displayed is very small, it may be that the AOUT signal (U1905 pin 5) is not being passed properly to U1902 pin 29. When test stops on this failure, there should be a 10 MHz signal on U1905 pin 5 to verify the oscillators and U1905 circuitry.

Table 6-6 (cont)

Error Label	Path, Devices Tested, and Troubleshooting Actions
A CTR OVERFLOW NOT DETECTABLE	Checks to see if A counter overflow flag will go high (Counter/Timer). Components to troubleshoot: U1902.
SCL FAULTY – TIMEBASE SELECT CIRCUIT NOT WORKING PROPERLY	Checks time-base selection circuitry in U1902 (Counter/Timer). Components to troubleshoot: U1902. Only possible cause is a faulty U1902 (SCL).

TROUBLESHOOTING HINTS BY DIAGRAM

Vertical SELF CAL – Checks Cursor and Pre-amplifier Outputs

The circuitry listed below must be operational for Vertical SELF CAL to work. Troubleshoot these circuits if voltage measurements or tracking cursors are not correct.

1. DAC system (U2303, U2304, and U2305, Diagram 11; U2601 and associated circuitry, Diagram 13).
2. Trigger Level Comparators (U431 and U421, Diagram 3).
3. VERT COMP feedback (U702, Diagram 2).
4. ECL-to-CMOS translators (Q604, Q605, Q606, Q607, Q602, and Q603) between U600 and U602 (Diagram 4).
5. Data to Measurement Processor (data bus and bus transceivers, Diagram 8).
6. VOLTS CAL signal (U931, Diagram 7).
7. Vertical Preamps (U210, U220, U230, and U240), Delay Line Drivers (Q250, Q251, Q252, and Q253), and Vertical Position Switching circuitry (U203, U801B, U201, U202, U280, Q284 and Q285, Diagram 2).

HORIZONTAL SELF CAL – Checks Sweep Timing

1. Put the oscilloscope into Self Cal and check at U421A pin 4 (Diagram 3) for changing width calibration signals.
2. Run the “EXERCISE TIME REF” exerciser and check for correct TB CAL signal at U421A pin 4, Diagram 3 (see Table 6-5).

Schematic Diagram 1 – Vertical INPUTS

1. Run DIAGNOSE to check for shift register failure.
2. Run the shift register exerciser for Shift Register 0. Check for clock, data, and strobe signals. Check the shift register outputs.

NOTE

The outputs of U171 and U172 are at 15 V; the outputs from U173 are at 5 V.

3. Check the outputs of the relay driver transistor arrays (U174 and U175). When a transistor is blown in one of the arrays, the usual symptom is 8 V on its output.
4. Go to a known setup and check the outputs for correct levels (see Circuit Description in Section 3). The MAKE FACTORY SETTINGS selection under INTERNAL SETTINGS of the SERVICE MENU provides known control states.
5. Check relay contacts.

6. Follow the signal path and check for correct signal and gains. Put in a known signal for each attenuator setting and check at the Vertical Preamplifier inputs to determine if the signal path is ok. The front panel boards and the attenuator shield have to be removed to gain access to the solder side of the Main Board.
7. Check the channel input buffer amplifier (U112 or U122) output if the vertical deflection of either channel 1 or channel 2 is defective. If the buffer amplifier output is held at -6 V or a strange sawtooth signal is present, replace that buffer amplifier.
8. Check gains and offsets of the CH 3 or CH 4 input buffers (Q131 or Q151).

Schematic Diagram 2—Vertical PREAMPLIFIERS, DELAY LINE DRIVERS and OUTPUT

Perform the following troubleshooting checks with no signal input.

1. Check both inputs of the delay line. If offset on either side, troubleshoot the offsetting side. Inputs to the bases of Q250 and Q251 should be at $+7.5\text{ V}$.
2. Differential voltage across the delay line should be $0\text{ V} \pm 0.5\text{ V}$.
3. Check signal gain through the Preamplifier ICs (U210, U220, U230, and U240). Gain is 10 mV /division of input signal.
4. Check INVERT operation.
5. Check the operation of U260 if the inputs to delay line driver are not at 7.5 V . This operational amplifier is the bias stabilization circuit that compares the average dc level to $+7.5$ and moves the emitters (and therefore the bases) of Q250 and Q251 to return the inputs to 7.5 V .

WARNING

Vertical output transistors Q701 and Q702 run extremely hot (in excess of 100°C). Use care when probing in those areas to not touch the heat sinks or cases with bare fingers.

WARNING

The vertical output amplifier runs hot. DO NOT touch it with bare fingers.

CAUTION

The metal tab on top of the vertical output amplifier IC (U701) is NOT ground. Do not connect a ground lead to it. Doing so may cause the IC to fail and usually causes R733 from pin 14 of U701 to the -5 V supply to open.

6. A common mechanical failure is lead breakage on R708. If the resistor pack is moved excessively, the leads will break. The resistor pack will then have to be replaced.

NOTE

The heat sinks on Q701 and Q702 may be removed for short periods of time to permit access for a test probe around the close-in circuitry. DO NOT leave them off for extended periods. Check that they are on all the way when replaced.

7. If the heat sinks on the output transistors shake loose, the plastic grommet inserted in the top of the heat sink prevents the sink from touching the metal cabinet. If the grommet is left out, then the metal cabinet may come in contact with the heat sink; and the transistor, the vertical output amplifier IC, and R733 will usually fail. If the heat sinks are removed during maintenance, they must fit tightly when replaced and the grommet must be checked.

NOTE

The cases of Q701 and Q702 are the base leads of the transistors, not the collector as is usual for a TO5 case. Also, the tab marks the collector lead, not the emitter.

8. The vertical outputs to the crt may be momentarily shorted together to check for offsets in the crt. (This should center the vertical trace.)
9. The output at pins 6 and 7 of U701 may be shorted together to check for offsets in the Vertical Preamplifier. (This should bring the trace to within ± 0.5 division of center.)

10. Pins 18 and 19 of U701 may be shorted together to check for offsets from the delay line. (This should bring the trace to within ± 1.5 divisions of center.)
11. Shorting the bases of Q701 and Q702 together usually causes the vertical output circuit to oscillate.
12. Check the center lead of R708 for a voltage of about +60 V, and a common-mode voltage difference (between the two deflection plates) of about 0 V (when pins 6 and 7 of U701 are shorted together).
13. Check the operation of Vertical Comparator U702 by noting if the TRACK MEASUREMENT cursors are off screen when called up. (The Vertical Comparator circuit is enabled only during a vertical Self Cal.)

Schematic Diagram 4 – DISPLAY AND TRIGGER LOGIC AND PROCESSOR INTERFACE

1. Put the oscilloscope into A Horizontal Display mode with CH 1 and CH 2 Vertical modes on.
2. Check U600 vertical enables (CH 1 EN, pin 39; CH 2 EN, pin 38)
3. Probe U600 A TRIG selects (ATS 0, pin 31; ATS 1, pin 32; ATS 2, pin 33; A SLOPE, pin 30) and B TRIG selects (BTS 0, pin 27; BTS 1, pin 28; BTS 2, pin 29; B SLOPE, pin 26) while making trigger source and slope changes on the front panel. (Probe the A select lines for A trigger changes and the B select lines for B trigger changes.)
4. Check the 10 MHz clock at U600 pin 1 and U600 power sources. Check the 1 kHz clock at pin 2.
5. Check communication lines ($\overline{\text{SLIC RD}}$, pin 8; $\overline{\text{SLIC WR}}$, pin 3; ADDR0 through ADDR3, pins 4 through 7, respectively; and MB DATA, pin 9) for activity while making front panel trigger-mode changes.
6. Check TH0 line, pin 17. Signal should go to a logic high then low again for every new front-panel setup condition, such as changing trigger mode, vertical mode, etc.
7. Check TDI, U600, pin 10, for a CMOS-level switching signal.
8. Check TDO, U602, pin 30, for an ECL-level switching signal.
9. Check the A TRIG signal at U602 pin 7.
10. Check the A GATE signal at U602 pin 14. Vary the Holdoff control to see if the spacing between each A GATE pulse changes.
11. Check the Holdoff oscillator output at U600 pin 15. Vary the HOLDOFF control to see if the width of the oscillator pulses varies.

Schematic Diagram 5 – A AND B SWEEPS AND DELAY COMPARATORS

1. Check that the baseline voltage (level that is present during holdoff after retrace) of the A and B ramp signals is -2 V. (The baseline level is referenced to the output of U309B and controlled by Q302, Q303, and Q304 for the A sweep and Q315, Q316, and Q317 for the B sweep).
2. Check the Sweep End Comparators, U316, for correct output. The sweep should end at a maximum of 2.5 V. Check the outputs (pin 15 for the A Sweep and pin 2 for the B Sweep) for about 3.8 V (the middle of ECL transitions).
3. Place the oscilloscope in delay and delta delay and check the Delay Time Comparators for correct outputs (DLY END 1 and DLY END 0).
4. Check U301 for correct switching and delay level transfer. Vary the Delay Time and the Delta Delay time and check for smooth signal change at pins 12 and 13 of U301C. If not correct, troubleshoot DAC system or front panel controls.
5. Run diagnostics to check for Shift Register 1 (U302 and U303) failure.
6. Exercise SR 1 and check switching of U307, U308, U310, and U311.

Schematic Diagram 6 – HORIZONTAL OUTPUT AMPLIFIER

1. Turn off the READOUT and check the ramps for equal (but opposite) waveforms on each plate. (Run MAKE FACTORY SETTINGS under the INTERNAL SETTINGS MENU in the SERVICE MENU.)



DO NOT short the horizontal output leads together or to ground. This will cause the output amplifier transistors to fail.

2. If output is railed to one side or the other, check U801A and the common-mode feedback. This circuit is supposed to keep the outputs at about 70 V average to ground.

NOTE

Pins 12 and 13 of U802 may be shorted together to determine if the unbalance is before or after the horizontal preamplifier (U802). DO NOT short to ground.

3. Check the A RAMP and B RAMP input signals (A Horizontal mode for A RAMP and B Horizontal mode for B RAMP). They start at -2 V and ramp up to about +2.5 V.
4. Check the RO HORIZ input for correct waveform.
5. Check for the X AXIS input signal on pin 7 of U802 in X-Y mode (a signal must be applied to the CH 1 input).
6. Check at the junction of R855 and R854 (the common-mode bias point of Q810 and Q809) for 9.5 V.
7. Check the HD0 and HD1 signals to U802 (see Table 6-7 for display states).
8. The horizontal preamplifier, U802, runs warm to the touch, but not hot.

Table 6-7
Horizontal Display State Logic

HD0	HD1	Display
0	0	Readout
0	1	A Sweep
1	0	B Sweep
1	1	X-Y

Schematic Diagram 7—Z-AXIS, CRT, PROBE ADJUST, AND CONTROL MUX

1. Turn off the Readout (READOUT control fully CCW) and test the node between CR2703 and C2711 for correct Z-Axis waveform. Vary INTEN to check operation. (Readout signals add confusion to the waveforms.)
2. Check for correct auto-focus operation at the junction of CR2715 and the collector of Q2712. Circuit action is exactly opposite of the Z-Axis to obtain focus tracking.
3. Parts replaced in the CRT High Voltage circuit and Z-Axis are safety controlled parts. Replacements need to be exact. The power supply is capable of delivering more than 15 watts at high voltages.

Schematic Diagram 8—MEASUREMENT PROCESSOR

1. Check U2501, pin 57 for a RESET condition. Processor will be in permanent reset condition if RESET is high. Check that RESET goes high then low again at power on.
2. Check $\overline{\text{SYS RESET}}$ at U2506C pin 8.
3. Check that U2502 pin 5 is low when RESET is high. (This signal prevents random RAM writes on power up and power down when the processor is being reset.)
4. Check the 8 MHz clock (CLK 8M) at U2501 pin 56.
5. Check address decoding. Use a data analyzer or word recognizer probe set up to recognize the address that produces a selected enabling strobe from the address-decoding circuitry. Observe that the strobe is produced when the correct address is output by the Measurement Processor. The easiest way to generate most addresses during normal operation is to change a front-panel setting. See Table 6-8 for the addresses.

Table 6-8
Measurement Processor I/O Memory Map

Address range (A19 - A0)					Signal Name and Description	Signal Source
Binary						
0110	0000	0000	0XXX	XXXX	$\overline{\text{LED CATH CLK}}$ – Latches cathode data to Front-Panel LEDs.	U2501 pin 25 (Diagram 8)
0110	0000	0000	1XXX	XXXX	$\overline{\text{LED ANODE CLK}}$ – Latches anode data to Front-Panel LEDs.	U2501 pin 27 (Diagram 8)
0110	0000	0001	0XXX	XXXX	$\overline{\text{RO BUF WR}}$ – Latches Readout Processor control datas.	U2501 pin 28 (Diagram 8)
0110	0000	0001	1XXX	XXXX	$\overline{\text{RO BUF RD}}$ – Enables Readout RAM data onto bus D0-D7 (used for diagnostics only).	U2501 pin 29 (Diagram 8)
0110	0000	0010	0XXX	X000	$\overline{\text{DAC BUF WR}}$ – Latches DAC Processor control data.	U2517 pin 15 (Diagram 8)
0110	0000	0010	0XXX	X001	$\overline{\text{DAC MSB CLK}}$ – Latches the most significant byte of data to the D-to-A Converter.	U2517 pin 14 (Diagram 8)
0110	0000	0010	0XXX	X010	$\overline{\text{POT MUX CLK}}$ – Latches channel selection code for pot multiplexer.	U2517 pin 13 (Diagram 8)
0110	0000	0010	0XXX	X010	$\overline{\text{SNAP CLK}}$ – Selects whether control of CH 1-CH 4 POSITION, TRACE SEP, A INTEN, B INTEN, and READOUT are controlled by front-panel pots or fixed resistor dividers.	U2517 pin 12 (Diagram 8)
1000	XXXX	XXXX	XXXX	X000	$\overline{\text{MB CNTL WR}}$ – Write enables Processor Interface circuitry (Diagram 4).	U2518 pin 15 (Diagram 8)
1000	0000	XXXX	XXXX	X000	Sets BEAM FIND (U503 pin 7) high ON.	U503 pin 7 (Diagram 4)
1000	XXXX	XXXX	XXXX	X001	$\overline{\text{SW BD SR LOAD}}$ – Loads column data into switch board registers.	U2518 pin 14 (Diagram 8)
1000	XXXX	XXXX	XXXX	X010	$\overline{\text{SW BD SR SHIFT}}$ – Shifts data in switch board registers to the SW BD DATA signal line.	U2518 pin 13 (Diagram 8)
1000	XXXX	XXXX	XXXX	X011	$\overline{\text{SLIC WR}}$ – Write to SLIC, U600 Diagram 4.	U2518 pin 12 (Diagram 8)

Table 6-8 (cont)

Address range (A19 - A0) ← Binary →					Signal Name and Description	Signal Source
1000	XXXX	XXXX	XXXX	X100	$\overline{\text{FLIC WR}}$ – Write to FLIC, U602 Diagram 4.	U2518 pin 11 (Diagram 8)
1000	0001	XXXX	XXXX	X000	SR 0 CLK – Clock Shift Register 0.	U606F pin 12 (Diagram 4)
1000	0010	XXXX	XXXX	X000	SR 1 CLK – Clock Shift Register 1.	U606B pin 4 (Diagram 4)
1000	0011	XXXX	XXXX	X000	Sets BEAM FIND (503 pin 7) low (OFF).	U503 pin 7 (Diagram 4)
1000	0011	XXXX	XXXX	X000	Sets MSEL (U602 pin 29) low (delta or long delay).	U503 pin 13 (Diagram 4)
1000	0100	XXXX	XXXX	X000	Sets MSEL (U602 pin 29) high reference or short delay).	U503 pin 13 (Diagram 4)
1000	0101	XXXX	XXXX	X000	Sets SR DATA signal line low.	U606C pin 6 (Diagram 4)
1000	0110	XXXX	XXXX	X000	Sets SR DATA signal line high.	U606C pin 6 (Diagram 4)
1000	0111	XXXX	XXXX	X000	Places SR 2 in shift mode (U502 pin 10, Diagram 4).	U2512 pin 5 (Diagram 8)
1000	1XXX	XXXX	XXXX	X000	A places SR 2 in load mode (U502 pin 10, Diagram 4).	U2512 pin 5 (Diagram 8)
1000	1111	XXXX	XXXX	X011	$\overline{\text{TRIG CLK}}$ – Loads coupling data to triggers.	U600 pin 19 (Diagram 4)
1001	XXXX	XXXX	XXXX	XXXX	Counter/Timer subsystem read/write enable.	U2501 pin 37 (Diagram 8)
1010	XXXX	XXXX	XXXX	XXXX	Chip enable for Measurement Processor RAM (U2521 pin 20).	U2501 pin 36 (Diagram 8)

Schematic Diagram 9 – READOUT SYSTEM

1. Run EXERCISE POTS (under the EXERCISER and FRONT PANEL menus) and check the digitized front panel pots for proper operation. The name of the exercised pot is displayed in the readout along with its current hexadecimal value. The value range from at or near 00 to at or near FF and the displayed value should change smoothly as the pot is rotated. EXERCISE POTS always displays the HORIZ POSITION pot when first called.
2. Check Readout Request pulse ($\overline{RO REQ}$, U2410 pin 14).
3. Check Readout Blanking signal ($\overline{RO BLANK}$, U2410 pin 16).
4. Check activity of Readout Processor (U2400).
5. Check outputs of Vertical and Horizontal Readout DACs (U2412 and U2413, respectively).
6. Check outputs of Vertical and Horizontal Readout Mixers (U2416A and U2416B, respectively) and multiplexers (U2414 and U2415, respectively).

Schematic Diagram 10 – SWITCH BOARD AND INTERFACE

1. Run the EXERCISE SWITCHES exerciser and check each of the front panel switches for correct operation. The circuit number of the latest switch pressed is displayed in the readout.
2. Run the EXERCISE LEDS exerciser and check that each of the front panel LEDS may be turned on. The circuit number of the lighted LED is displayed in the readout.

Schematic Diagram 11 – ADC, DAC SYSTEM and 13 – DAC SUBSYSTEM

1. Run EXERCISE DACS (under EXERCISER, PROC BOARD, and A TO D menus) and probe the demultiplexed outputs of U2303 (Diagram 11), U2604 and U2605 (Diagram 13) and each of the sample-and-hold circuits for proper operation.
2. Run EXERCISE PORTS (under EXERCISER, PROC BOARD, and A TO D menus) and trace the signal path of any problems with the A-to-D Converter.

Schematic Diagram 14 – POWER SUPPLY

WARNING

For safety reasons, an isolation transformer must be connected whenever troubleshooting is done in the Preregulator and Inverter Power Supply sections of the instrument.

1. If the fuse blows, check that Q2201 is not shorted. (If a variac is available, slowly increase the line voltage from 0 V until the voltage across C2202 is about 40 V. If the same voltage is across C2203, Q2201 is probably shorted.)
2. If the Preregulator fails to come up (44 V not present across C2203):
 - a. Check +DC at the output of the line rectifier bridge (across C2202) for approximately ($V_{ACRMS} \times 1.414$).
 - b. Check the Start-up circuit. The voltage across C2204 should ramp up to about 20 V, at which point Q2204 and Q2211 turn on to supply voltage to pin 10 of U2201.
 - c. Check the Preregulator circuit. Voltage pulses with a repetition rate of about 25 μ s should be present on pin 8 of U2201 whenever supply voltage is present on pin 10.
3. If the power supply is in the chirp mode (continually restarting and shutting down), excessive loading of the +44 V supply is probable.

WARNING

To avoid electrical shock, always disconnect the instrument from the ac power source before removing or replacing components.

- a. Check that Q2209 and/or Q2210 are not shorted. Open W2201 and connect the positive lead of an ohmmeter to either collector and the negative lead to the emitters. Readings of less than 100 Ω indicate a probable short. If a short is found, it will be necessary to unsolder one of the collector leads to determine which transistor is shorted. Reconnect W2201 when done.

- b. Check the secondary supplies for excessive loading. Measure from each supply to ground using an ohmmeter at a low range (one that will forward bias diodes, usually around the 1 k Ω range). Use the following as a guideline:

<u>Supply</u>	<u>Nominal Resistance Ohms</u>
+ 5 V	100
-5 V	50
-15 V	500
+ 15 V	400
+ 7.5 V	150
-7.5 V	180
+ 58 V	7500
+ 130 V	9000

TROUBLESHOOTING MEASUREMENT ERRORS

When certain measurement malfunctions occur, the symptoms usually indicate the circuit components that may be causing the problems. Read the following text to become familiar with the terms used in describing a measurement failure problem and the setup conditions needed to determine the symptoms. Then use Table 6-9 to check for measurement malfunction symptoms and probable causes.

1. Verify all the following conditions and read the definitions before attempting to use Table 6-9 for locating the source of measurement-error problems.

Conditions:

All vertical channels can be successfully displayed and positioned independently.

The A and B sweeps both free-run and trigger successfully.

Both A and B Trigger COUPLING and SOURCE operate properly.

Normal-appearing readout text and cursors can be displayed.

Definition of terms:

Type 1 volts measurements are:

← VOLTS→ and ↗ VOLTS→

Type 2 volts measurements are:

DC

Type 3 volts measurements are:

+ PEAK, -PEAK, PK-PK

Type 4 volts measurements are:

GATED + PEAK, GATED -PEAK, and GATED PK-PK

Measurement value accuracy is the accuracy of number displayed in top line of readout on the crt.

Measurement cursor accuracy is the accuracy of the match between cursor position and the measurement value.

Trigger value accuracy is the accuracy of the number displayed on the trigger level cursor.

Trigger cursor accuracy is the accuracy of the match between cursor position the value displayed on the cursor.

A TL is the A trigger level measurement system.

B TL is the B trigger level measurement system.

Table 6-9
Measurement Error Troubleshooting Hints

Circuit Problem	Symptoms
VERTICAL INPUTS (schematic Diagram 1)	
Ground relay stuck in signal position	Gross value problems for Types 1-4 volts measurements. Gross value problems A TL and B TL.
	Test: Use "EXERCISE VOLT REF." Check that the ground relay is in ground position.
Defective X10, X100, X1, X2, X5 Relays and Attenuators	Gross value problems for affected channel for Types 1-4 volts measurements. Gross value problems in A TL and B TL.
	Test: Check channel accuracy at all VOLTS/DIV settings.
ZERO HYST line stuck low (U173-13)	In Type 4 measurements, minor value problems for +PK cursors when gating interval is at negative end of waveform, and for -PK cursors when gating interval is at positive end of waveform.
	Test: Turn off all measurements; use the A Horizontal Mode. U431 pin 28 should be -3.0 volts. Switch to ALT Horizontal Mode. U431 pin 28 should be -0.7 volts.
RO FREEZE line stuck high (U173-11)	Gross cursor problems for Types 2, 3, and 4 measurements. Gross cursor problems for A TL and B TL. Gross valve problems with Type 1 measurements.
	Test: Monitor during CH 1/CH 2 VOLTMETER menu SELF CAL. Signal line should reach TTL low.
VERTICAL PREAMP AND OUTPUT AMPLIFIER (schematic Diagram 2)	
Preamp Trig Outputs Bad	Gross value problems for Types 2, 3, and 4 measurements for affected channel.
	Test: Check B triggering on the affected channel.
Preamp Vert Outputs or Enable Bad	Gross cursor problems for Types 2, 3, and 4 measurement for affected channel. Gross value accuracy problems for Type 1 measurements for affected channel.
	Test: With only the affected channel selected for display, check that channel is shown and check gain accuracy.
VERT COMP output (U702-7)	Gross value problems with Type 1 measurements. Gross cursor problems with Types 2, 3, and 4 measurements. Gross cursor problems with A TL and B TL.
	Test: Lift W1101 and ground the base of Q703. VERT COMP should be toggling between TTL high and TTL low either with readout on or with two channels on (one at screen top, one at screen bottom).

Table 6-9, (cont)

Circuit Problem	Symptoms
A AND B TRIGGER SYSTEM (schematic Diagram 3)	
A Trig Source Multiplexer (U421A)	<p>“SEARCH FAILED AT 5 μs” for “SELF CAL” on time measurements unless stuck in LINE.</p> <p>Minor to gross value problems (depending on which source is stuck) with the A TL measurement.</p> <p>Test: Set A Trigger SOURCE to VERT. For each channel, display only that channel and check that the signal applied to the displayed channel appears at pin 25 of U421.</p>
A Trig Cplg Multiplexer (U421B)	<p>May get “SEARCH FAILED at . . .” for “SELF CAL” on time measurements if coupling is stuck in HF REF coupling.</p> <p>Minor to gross value problems with the A TL if coupling is stuck in any position except DC.</p> <p>Test: Switch between all A Trigger COUPLING settings with a 10 kHz square wave connected to CH 1 input; use CH 1 for the A Trigger SOURCE and set A Trigger SLOPE to \sim.</p> <p>Check signal at U421 pin 25 (square edge for DC or NOISE REJ; rounded corner for HF REJ; spiked corner for LF REJ; signal center shifts to ground for AC).</p>
A Trig line stuck high or low (U421C-10)	<p>“SEARCH FAILED AT 5 μs for SELF CAL” on time measurements. Gross value problems with A TL.</p> <p>Test: Set the A Trigger mode to NORM. Check that the sweep can be triggered on the Channel 1 signal.</p>
B Trig Source Multiplexer (U431A)	<p>Minor to gross value problems (depending on which bit is stuck) with types 2, 3, and 4 measurements.</p> <p>Minor to gross value problems with B TL. “SEARCH RETURNED BAD VALUE AT . . .” on time measurements (unless stuck in LINE SOURCE).</p> <p>Test: Set B Trigger Source to VERT. For each channel, display only that channel and check that the signal applied to the displayed channel appears at U431 pin 25.</p>
B Trig Cplg Multiplexer (U431B)	<p>Minor to gross value problems with Types 3 and 4 measurements (depending on which coupling bit is stuck).</p> <p>Gross value problems with Type 2 measurements (unless stuck in measurement mode input).</p> <p>Minor to gross value problems with B TL.</p>
B Trig BW Limit circuitry	<p>Minor value problems with Type 3 and 4 measurements if stuck in limited BW position.</p> <p>Minor value problems with Type 2 measurements if stuck in full BW position.</p>

Table 6-9, (cont)

Circuit Problem	Symptoms
BW FULL B line (U1103-14)	See notes on "B Trig BW limiter."
	Test: Should be CMOS low when SCOPE BW button is lit. Should be CMOS high when SCOPE BW button is not lit; use ALT Horizontal Mode with B CPLG set to DC.
B Trig (U431C)	Gross value problems with Types 2, 3, and 4 measurements. Gross value problems with B TL. "SEARCH RETURNED BAD VALUE AT . . ." on time measurements.
B TV TRIG EN line stuck high (U1103-4)	Gross value problems with Type 2 measurements.
	Test: Run CH 1/CH 2 VOLTMETER DC measurement and check that the B TV TRIG EN signal is at TTL low.
VERT COMP EN line stuck high (U1103-7)	See notes on "VERT COMP" (schematic Diagram 2).
	Test: VERT COMP EN should be at CMOS high in normal use. Run "SELF CAL" from the CH 1/CH 2 VOLTMETER menu and check that VERT COMP EN goes to a CMOS low.
LINE/TIME BASE CAL signal Mux stuck in LINE position (U1106A)	"RETURNED BAD SEARCH VALUE AT . . ." from "SELF CAL" for time measurements.
	Test: Run "EXERCISE TIME REF" diagnostic and check the output of U1106A (pin 1) for changing signal.
B Trig Level Multiplexer and Output Filter (U1106B and associated components)	Counter/Timer Rise- or Fall-Time measurement result too low, but Rise/Fall Time value displayed gets significantly higher when Trigger HOLDOFF control is rotated clockwise.
	Check input to B Trigger Comparator (U431 pin 25) for excessive B Trig Level settling time when HOLDOFF is at MIN position.
DC Average circuit (U1101B)	Gross value problems for Type 2 measurements (minor value problems with low frequencies if RC values in the filter are incorrect).
	Test: Display only CH 1, run DC measurement. Apply to 50 Hz sine-wave signal with a DC offset to the CH 1 input. Check that only the dc value appears at output of the DC Average circuit.

**DISPLAY AND TRIGGER LOGIC AND PROCESSOR INTERFACE
(schematic Diagram 4)**

MB RETURN line (U502-12)	See notes on VERT COMP (schematic Diagram 2).
MP DLY SEL line (U503-13 or MP DLY SEL Interface (U602)	"SEARCH RETURNED BAD VALUE AT 5 μs" on time measurements.
	Test: Turn all measurements off. Use the A Horizontal mode. The MP DLY SEL signal should be at a TTL high.

Table 6-9, (cont)

Circuit Problem	Symptoms
SR DATA line (U606C-6)	Effects are the same as those caused by malfunctions in SR 0 and SR 1.
	Test: The A Sweep rate changes when SEC/DIV knob is rotated in the A Horizontal Display Mode.
SR 0 CLK line (U606F-12)	Effects are the same as those caused by malfunctions in SR 0.
	Test: Channel 1 sensitivity changes when CH 1 VOLTS/DIV knob is rotated.
SR 1 CLK line (U606B-4)	Effects same as those caused by malfunctions in SR 1.
	Test: Check that the A Sweep rate changes when SEC/DIV knob is rotated in the A Horizontal Display Mode.
SR 1 CLK TTL line (U501-13)	Effects same as those caused by malfunctions in auxiliary section of SR 1 (U1103, Diagram 3).
	Test: HF noise in trace reduces when SCOPE BW button is lit and increases when not lit.
Processor-to-Display- Sequencer Interface (U600)	Gross effects on all voltage and time measurements.
	Test: Run DIAGNOSE and note results of SLIC CONTROL REG test; Set the A Trigger Mode to NORM; check that the ATS 0-2 signal lines (pins 31-33) change when the A Trigger SOURCE is changed. Check that no "LOW REP RATE" warning occurs with Type 4 measurements.
TDO Level Shifter (U603, Q603, Q602)	Same as Processor-to-Display-Sequencer Interface problem.
	Test: Using NORM mode for both triggers, VERT source for both triggers, and CH 1 only displayed; apply a four-division, square-wave signal to the CH 1 input.
	In the A Horizontal mode, check that the Trig'd LED light goes off and the sweep stops running with the Trigger LEVEL control at full CW rotation.
	Change to AUTO mode for A trigger; check that sweep free runs with the Trigger LEVEL control at full CW rotation.
	Check that the Trig'd LED can be lit and the sweep can be triggered when the Trigger Level is set to within the signal limits. Keep the A Sweep triggered for the next check.
	In B Horizontal mode, check that the Trig'd LED goes off, and the sweep stops running with the Trigger LEVEL control set at full CW rotation.
Check that the Trig'd LED can be lit and the sweep made to trigger when Trigger Level is set to within the signal limits.	
Change to RUNS AFTER Mode for the B Trigger. Check that the B Sweep free runs.	

Table 6-9, (cont)

Circuit Problem	Symptoms
DLY SEL line stuck low (U602-32)	<p>“SEARCH RETURNED BAD VALUE AT 5 μs” for “SELF CAL” on time measurements.</p> <p>Test: Use settings given in previous test. Set the first delay zone to the start of the sweep with \leftarrow control. Check that the second delay zone can be positioned over the entire sweep length with the \rightarrow control.</p>
DLY SEL line stuck high (U602-32)	<p>“SEARCH RETURNED BAD VALUE AT 0.1 ms” for “SELF CAL” on time measurements.</p> <p>Test: Use settings given in previous test. Set the first delay zone to the start of the sweep with \leftarrow control. Check that the second delay zone can be positioned over the entire sweep length with the \rightarrow control.</p>
ATS 0-2 (U600, pins 31-33) A Trig Source Multiplexer	See notes on “A Trig Source Multiplexer” (schematic Diagram 4).
BTS 0-2 (U600, pins 27-29) B Trig Source Multiplexer	See notes on “B Trig Source Multiplexer” (schematic Diagram 3).
B SLOPE line stuck high (U600-26)	<p>Gross problems with + PEAK value, Types 2, 3, and 4 measurements.</p> <p>Gross value problems with the B TL measurement.</p>
TRIG CLK line (U600-19)	See notes on “A Trig Cplg Multiplexer” and “B Trig Cplg Multiplexer” (U421 and U431, Diagram 3).
A AND B SWEEP AND DELAY COMPARATORS (schematic Diagram 5)	
DLY END 0 line stuck low or high (U315-15)	<p>“SEARCH RETURNED BAD VALUE AT 5 μs” for “SELF CAL” on time measurements.</p> <p>Test: Run the \leftarrow TIME \rightarrow measurement in ALT Horizontal Mode with the A SEC/DIV at 1 ms/div and the B SEC/DIV at 0.1 ms/div. Check that the first delay zone can be positioned over the length of sweep using the \leftarrow control.</p>
Ref/Delta Delay Muxes stuck (U301A & C)	See notes on DLY SEL (schematic Diagram 4).
A Sweep Control circuit (U302 & U303)	<p>“SEARCH RETURNED BAD VALUE AT (affected SEC/DIV setting)” for “SELF CAL” on time measurements.</p> <p>Test: Use “EXERCISE VOLT REF” diagnostic.</p>
VOLT CAL 0-2 (U302 & U303)	<p>Gross value problems with Types 1, 2, 3, and 4 measurements.</p> <p>Gross value and cursor problems with A TL and B TL.</p> <p>Test: Use “EXERCISE VOLT REF” diagnostic.</p>

Table 6-9, (cont)

Circuit Problem	Symptoms
Z-AXIS, CRT, PROBE ADJUST, AND CONTROL MUX (schematic Diagram 7)	
VOLT CAL line (U931-3)	<p>Gross value problems with types 1, 2, 3, and 4 measurements. Gross value and cursor problems with A TL and B TL.</p> <p>Test: Use "EXERCISE VOLT REF" diagnostic.</p>
MEASUREMENT PROCESSOR (schematic Diagram 8)	
TB CAL line (U2501-22)	<p>"SEARCH FAILED AT SWEEP SPEED . . ." in "SELF CAL" on time measurements.</p> <p>Test: Use "EXERCISE TIME REF" diagnostic. Check that TB CAL signal is correct and signal path is intact to U421A pin 4 (Diagram 3) through U1106A.</p>
SLIC WR (U2518-12)	See notes on "Processor-to-Display-Sequencer Interface" (schematic Diagram 4).
SLIC RD (U2503C-8)	See notes on "Processor-to-Display-Sequencer Interface" (schematic Diagram 4).
FLIC WR (U2518-11)	See notes and tests on "TDO Level Shifter" (schematic Diagram 4).
MB DATA (U2515-11)	See notes on "Processor-to-SLIC Interface" (schematic Diagram 4).
Field & Mixer Control Latch or Readout Position Mixer stuck (U2411, U2414, U2415)	<p>Gross cursor problems with Types 1, 2, 3, and 4 measurements. Gross cursor problems with A TL and B TL.</p> <p>Test: Run ← VOLTS → CURSOR Measurement mode with only CH 1 displayed. Check that cursors move the CH 1 position control. Check that ← cursor moves with ← control and → cursor moves with → control. Check that top and bottom line of readout do not move with any position control.</p>
ADC, DAC SYSTEM (schematic Diagram 11)	
A TRIG LVL (U2304C-8)	<p>See notes for "A TRIG" (schematic Diagram 3).</p> <p>Test: Select A trigger, set A Trig mode to NORM. Check that A TRIG LVL can be set to any value from -2.5 to +2.5 volts using the Trigger LEVEL control.</p>
B REF TRIG LVL (U2304B-7)	<p>See notes for "B TRIG" (hints for schematic Diagram 3).</p> <p>Test: Select B trigger, set B Trig mode to NORM, and select B Horizontal mode. Check that B REF TRIG LVL can be set to any value from -2.5 to +2.5 volts with Trigger LEVEL pot.</p>

Table 6-9, (cont)

Circuit Problem	Symptoms
REF DLY (U2305C-8)	<p>“RETURNED BAD SEARCH VALUE AT . . .” for “SELF CAL” on time measurements.</p> <p>Test: Run ← TIME → measurement in ALT Horizontal mode; A at 1 ms/div, B at 0.1 ms/div.</p> <p>Check that first delay zone can be positioned over length of sweep with the ← control.</p>
DELTA DELAY (U2305B-7)	<p>“RETURNED BAD SEARCH VALUE AT . . .” for “SELF CAL” on on time measurements.</p> <p>Test: Use the preceding REF DELAY settings, and set first delay zone to start of sweep with ← control.</p> <p>Check that second delay zone can be positioned over length of sweep with → control.</p>
REF CURSOR (U2304D-14)	<p>Gross value problems with Type 1 measurements.</p> <p>Gross cursor problems with Types 2, 3, and 4 measurements.</p> <p>Gross cursor problems with A TL and B TL.</p> <p>Test: Run ← VOLTS → CURSOR Measurement Mode.</p> <p>Check that ← cursor can be positioned ±15 divisions around the trace ground.</p>
DELTA CURSOR (U2304A-1)	<p>Gross value problems with Type 1 measurements.</p> <p>Gross cursor problems with Types 2, 3, and 4 measurements.</p> <p>Gross cursor problems with A TL and B TL.</p> <p>Test: Run ← VOLTS → CURSOR Measurement Mode.</p> <p>Check that → cursor can be positioned ±15 divisions around the trace ground level.</p>
COUNTER/TIMER (schematic Diagram 12)	
Crystal Oscillator (Q1901/Y1901) or Phase-Locked-Loop (Q1903 and associated components)	<p>Frequency and Period measurement errors in the range of 3% or more.</p> <p>Check that Counter/Timer is getting a proper trigger signal. If so, check crystal oscillator and PLL circuits for proper operation. Run the DIAGNOSE routine.</p>

CORRECTIVE MAINTENANCE

INTRODUCTION

Corrective maintenance consists of component replacement and instrument repair. This part of the manual describes special techniques and procedures that are needed to replace components in this instrument. If it is necessary to ship your instrument to a Tektronix Service Center for repair or service, refer to the Repackaging for Shipment information in this section.

MAINTENANCE PRECAUTIONS

To reduce the possibility of personal injury or instrument damage, observe the following precautions.

1. Disconnect the instrument from the ac-power source before removing or installing components.
2. Verify that the line-rectifier filter capacitors are discharged prior to performing any servicing.
3. Use care not to interconnect instrument grounds which may be at different potentials (cross grounding).
4. When soldering on circuit boards or small insulated wires, use only a 15-watt, pencil-type soldering iron.



Do not exceed 9 in-lb of torque when tightening the 6-32 screws.

5. Use care not to overtighten screws into chassis. Threads that have been formed directly into aluminum components can be stripped out. If this occurs, use a 6-32 nut to secure the screw.

WARNING

Portions of the power supply are floating at the ac line voltage level and pose a shock hazard if not isolated from ground.

6. Use an isolation transformer to supply power to the 2247A if you troubleshoot in the power supply with power applied to the instrument.

OBTAINING REPLACEMENT PARTS

Electrical and mechanical replacement parts can be obtained through your local Tektronix Field Office or representative. However, many of the standard electronic components may be obtained from a local commercial source. Before purchasing or ordering a part from a source other than Tektronix, Inc., please check the Replaceable Electrical Parts list for the proper value, rating, tolerance, and description.

NOTE

The physical size and shape of a component may affect instrument performance, particularly at high frequencies. Always use direct-replacement components, unless it is known that a substitute will not degrade instrument performance. Parts in the crt high-voltage and Z-Axis circuits are safety-controlled—USE EXACT REPLACEMENTS in these circuits.

Special Parts

In addition to the standard electronic components, some special parts are used in the 2247A. These components are manufactured or selected by Tektronix, Inc. to meet specific performance requirements, or are manufactured for Tektronix, Inc. in accordance with our specifications. The various manufacturers can be identified by referring to the Cross Index-Manufacturer's Code number to Manufacturer at the beginning of the Replaceable Electrical Parts list (Section 8). Most of the mechanical parts in this instrument are manufactured by Tektronix, Inc. Order all special parts directly from your local Tektronix Field Office or representative.

Ordering Parts

When ordering replacement parts from Tektronix, Inc., be sure to include all of the following information:

1. Instrument type (include modification or option numbers).

2. Instrument serial number.
3. A description of the part (if electrical, include its full circuit component number).
4. Tektronix part number.

REPACKAGING FOR SHIPMENT

Save the original carton and packing material for reuse if the instrument should have to be reshipped on a commercial transport carrier. If the original materials are unfit or not available, repackage the instrument as follows:

1. Use a corrugated cardboard shipping carton with a test strength of at least 275 pounds and with an inside dimension at least six inches greater than the instrument dimensions.
2. If instrument is being shipped to a Tektronix Service Center, enclose the following information: the owner's address, name and phone number of a contact person, type and serial number of the instrument, reason for returning, and a complete description of the service required.
3. Completely wrap the instrument with polyethylene sheeting or equivalent to protect the outside finish and prevent entry of foreign materials into the instrument.
4. Cushion the instrument on all sides, using three inches of padding material or urethane foam tightly packed between the carton and the instrument.
5. Seal the shipping carton with an industrial stapler or strapping tape.
6. Mark the address of the Tektronix Service Center and also your own return address on the shipping carton.

MAINTENANCE AIDS

The maintenance aids listed in Table 6–10 include items required for performing most of the maintenance procedures in this instrument. Equivalent products may be substituted for the examples given if their characteristics are similar.

INTERCONNECTIONS

Several types of mating connectors are used for the interconnecting cable pins. The following information gives the replacement procedures for the various connectors:

End–Lead Pin Connectors

Pin connectors used to connect the wires to the interconnect pins are factory assembled. They consist of machine–inserted pin connectors mounted in plastic holders. If the connectors are faulty, the entire wire assembly should be replaced.

Ribbon–Cable Connectors

The etch–ribbon cables have the connector pins crimped onto the wire runs. If the connectors are defective, the entire ribbon cable assembly must be replaced.

LITHIUM BATTERY (B2501)

The lithium battery used to supply backup power to the System RAM should last for at least 5 years. However, when it becomes necessary to replace the battery, be sure to observe the following general warning about disposal of lithium batteries.

WARNING

To avoid personal injury, observe proper procedures for handling and disposal of lithium batteries. Improper handling may cause fire, explosion, or severe burns. Do not recharge, crush, disassemble, heat the battery above 212°F (100°C), incinerate, or expose contents of the battery to water. Dispose of battery in accordance with local, state, and national regulations.

Typically, small quantities (less than 20) can be safely disposed of with ordinary garbage in a sanitary landfill. Larger quantities must be sent by surface transport to a hazardous waste disposal facility. The batteries should be individually packaged to prevent shorting and packed in a sturdy container that is clearly labeled "Lithium Batteries – DO NOT OPEN."

Table 6-10
Maintenance Aids

Description	Specification	Usage	Example
Soldering Iron	15 to 25 W.	General soldering and unsoldering.	Antex Precision Model C.
Torx Screwdriver Tips and Handle	Torx tips: #T7, #T9, #T10, #T15, and #T20. Handle: 1/4 inch hex drive.	Assembly and disassembly.	Tektronix Part Numbers: #T7 003-1293-00 #T9 003-0965-00 #T10 003-0814-00 #T15 003-0966-00 #T20 003-0866-00 Handles: 8 1/2 in. 003-0293-00 3 1/2 in. 003-0445-00
Nutdrivers	1/4 inch, 5/16 inch, 1/2 inch, and 9/16 inch.	Assembly and disassembly.	Xcelite #8, #10, #16 and #18.
Open-end Wrench	9/16 inch and 1/2 inch.	Channel Input and Ext Trig BNC Connectors	Tektronix Part Numbers: 9/16) 003-0502-00 1/2) 003-0822-00
Hex Wrenches	0.050 inch, 1/16 inch.	Assembly and disassembly.	Allen wrenches.
Long-nose Pliers		Component removal and replacement.	Diamalloy Model LN55-3.
Diagonal Cutters		Component removal and replacement.	Diamalloy Model M554-3.
Vacuum Solder Extractor.	No Static Charge Retention.	Unsoldering static sensitive devices and components on multi-layer boards.	Pace Model PC-10.
Contact Cleaner	No-Noise.®	Switch and pot cleaning.	Tektronix Part Number 006-0442-02.
Pin-replacement Kit		Replace circuit board connector pins.	Tektronix Part Number 040-0542-01.
IC-removal Tool		Removing DIP IC packages.	Augat T114-1.
Isopropyl Alcohol	Reagent grade.	Cleaning attenuator and front-panel assemblies.	2-Isopropanol.
Isolation Transformer		Isolate the instrument from the ac power source for safety.	Tektronix Part Number 006-5953-00.
1X Probe		Power supply ripple check.	TEKTRONIX P6101A.

TRANSISTORS AND INTEGRATED CIRCUITS

WARNING

Transistors and integrated circuits should not be replaced unless they are actually defective. If one is removed from its socket or unsoldered from the circuit board during routine maintenance, return it to its original board location. Unnecessary replacement or transposing of semiconductor devices may affect the adjustment of the instrument. When a semiconductor is replaced, check the performance of any circuit that may be affected.

To avoid an electrical-shock hazard, observe the following precautions before attempting any soldering: turn the instrument off, disconnect it from the ac power source, and wait at least three minutes for the line-rectifier filter capacitors to discharge.

Any replacement component should be of the original type or a direct replacement. Bend component leads to fit their circuit board holes, and cut the leads to the same length as the original component. See Figure 9-2 in the Diagrams section for the semiconductor lead-configurations.

Use rosin-core wire solder containing 63% tin and 37% lead. Contact your local Tektronix Field Office or representative to obtain the names of approved solder types.

When soldering on circuit boards or small insulated wires, use only a 15-watt, pencil-type soldering iron. A higher wattage soldering iron may cause etched circuit conductors to separate from the board base material and melt the insulation on small wires. Always keep the soldering-iron tip properly tinned to ensure the best heat transfer from the tip to the solder joint. Apply only enough solder to make a firm joint. After soldering, clean the area around the solder connection with an approved flux-removing solvent (such as isopropyl alcohol) and allow it to air dry.



After replacing a power transistor, check that the collector is not shorted to the chassis before applying power to the instrument.

To remove socketed dual-in-line packaged (DIP) integrated circuits, pull slowly and evenly on both ends of the device. Avoid disengaging one end of the integrated circuit from the socket before the other, since this may damage the pins.

To remove a soldered DIP IC when it is going to be replaced, clip all the leads of the device and remove the leads from the circuit board one at a time. If the device must be removed intact for possible reinstallation, do not heat adjacent conductors consecutively. Apply heat to pins at alternate sides and ends of the IC as solder is removed. Allow a moment for the circuit board to cool before proceeding to the next pin.



Only an experienced maintenance person, proficient in the use of vacuum-type desoldering equipment should attempt repair of any circuit board in this instrument. Many integrated circuits are static sensitive and may be damaged by solder extractors that generate static charges. Perform work involving static-sensitive devices only at a static-free work station while wearing a grounded antistatic wrist strap. Use only an antistatic vacuum-type solder extractor approved by a Tektronix Service Center.

SOLDERING TECHNIQUES

The reliability and accuracy of this instrument can be maintained only if proper soldering techniques are used to remove or replace parts. General soldering techniques that apply to maintenance of any precision electronic equipment should be used when working on this instrument.



Attempts to unsolder, remove, and resolder leads from the component side of a circuit board may cause damage to the reverse side of the circuit board. The following techniques should be used to replace a component on a circuit board:

1. Touch the vacuum desoldering tool tip to the lead at the solder connection. Never place the tip directly on the board; doing so may damage the board.

NOTE

Some components are difficult to remove from the circuit board due to a bend placed in the component leads during machine insertion. To make removal of machine-inserted components easier, straighten the component leads on the reverse side of the circuit board.

2. When removing a multipin component, especially an IC, do not heat adjacent pins consecutively. Apply heat to the pins at alternate sides and ends of the IC as solder is removed. Allow a moment for the circuit board to cool before proceeding to the next pin.



Excessive heat can cause the etched circuit conductors to separate from the circuit board. Never allow the solder extractor tip to remain at one place on the board for more than three seconds. Solder wick, spring-actuated or squeeze-bulb solder suckers, and heat blocks (for desoldering multipin components) must not be used. Damage caused by poor soldering techniques can void the instrument warranty.

3. Bend the leads of the replacement component to fit the holes in the circuit board. If the component is replaced while the board is installed in the instrument, cut the leads so they protrude only a small amount through the reverse side of the circuit board. Excess lead length may cause shorting to other conductive parts.
4. Insert the leads into the holes of the board so that the replacement component is positioned the same as the original component. Most components should be firmly seated against the circuit board.
5. Touch the soldering iron tip to the connection and apply enough solder to make a firm solder joint. Do not move the component while the solder hardens.

6. Cut off any excess lead protruding through the circuit board (if not clipped to the correct length in step 3).
7. Clean the area around the solder connection with an approved flux-removing solvent. Be careful not to remove any of the printed information from the circuit board.

REMOVAL AND REPLACEMENT INSTRUCTIONS

WARNING

To avoid electric shock, disconnect the instrument from the power input source before removing or replacing any component or assembly.

The exploded view drawings in Replaceable Mechanical Parts list may be helpful during removal and reinstallation of individual components or sub-assemblies. Circuit board and component locations are shown in Diagrams section.

Read these instructions before attempting to remove or install any components.

Cabinet

To remove the cabinet:

1. Unplug the power cord from its rear-panel connector.
2. Place the instrument face down on a clean, flat surface.
3. Remove the Torx-head screw from the right side near the rear of the cabinet.
4. Remove the plastic rear cover, held with four Torx-head screws.
5. Slide the cabinet housing up and off the instrument.

WARNING

Potentially dangerous voltages exist at several points throughout this instrument. If it is operated with the cabinet removed, do not touch exposed connections or components. Before replacing parts or cleaning, disconnect the ac-power source from the instrument and check that the line-rectifier filter capacitors have discharged. Also, check the low voltages at the Power-Supply/Main-Board interface connector (J1024). If any of the supply-voltage or line-voltage filter capacitors remain charged for more than 20 seconds, discharge them to ground through a 1 k Ω , 5- or 6-watt resistor.

To install the cabinet:

6. Carefully slide the cabinet housing over the rear of the instrument. Be careful not to snag any of the folded ribbon cables. Make sure the cabinet housing slides between the plastic front-panel housing and the instrument chassis.
7. Install the rear-panel. Secure it with four #15 Torx-head screws.
8. Install a Torx-head screw in the right side of the cabinet.

Crt Removal and Replacement

WARNING

Use care when handling a crt. Breaking the crt can cause high-velocity scattering of glass fragments. Protective clothing and safety glasses or safety face shield should be worn. Avoid striking the crt on any object which might cause it to crack or implode. When storing a crt, either place it in a protective carton or set it face down on a smooth surface in a protected location with a soft mat under faceplate.

To remove the crt:

WARNING

To avoid electrical shock, carefully discharge the crt anode lead directly to the metal chassis. To avoid static-discharge damage to electronic components, do not allow the anode lead to discharge into the adjacent circuitry.

1. Disconnect the high-voltage anode lead. Pull the anode-lead coupler apart slowly and carefully. DO NOT touch the exposed connector pin as it is withdrawn from coupler socket. Discharge the exposed anode pin to the metal chassis only. A hole is provided in the left side of the power supply chassis for the purpose of holding the end of the lead to prevent a recharge while it is disconnected.
2. Unplug the trace rotation cable (P27) from the Main board.
3. Unplug the two vertical and the two horizontal deflection leads from the crt neck. Grasp each lead connector with long-nosed pliers and pull it straight away from the crt neck pins. Be careful not to bend the neck pins.
4. Remove the crt implosion shield and bezel frame (held with two screws at the lower side).
5. Place your left hand on crt neck shield and your right hand over crt face. Move the crt assembly forward to unplug the crt from its socket and carefully withdraw it from the instrument while ensuring that the crt anode lead clears all obstructions. Do not hold the crt assembly by the shield only.
6. If it is necessary remove the metal shield from crt. Carefully slide the shield to rear of the crt. Be careful not to damage the neck pins.

To install the crt:

7. Install the metal shield over the neck of the crt. Make sure that the plastic grommet is in place over the front of the shield. Align the neck pins with the shield holes.
8. Check that the graticule scale-illumination light pipe is in place at bottom front of crt opening. Also make sure that the four crt corner cushions are in place in the crt opening of the subpanel.

9. Carefully guide the crt, anode lead, and trace rotation cable into the instrument. Line up the crt base pins with base socket. Make sure that the ground clip above the rear of the crt shield goes outside of the shield. Hold in on the rear of the base socket with one hand and push on the face of the crt with the other hand to completely seat the crt base pins. If the crt will not go in all the way, check for bent pins. DO NOT FORCE this connection!
10. Connect the trace rotation cable (P27) to the Main board.
11. Connect the vertical and horizontal deflection leads to the crt neck pins. The horizontal deflection leads (going to bottom pins) should be crossed.
12. Connect the high-voltage anode lead.
13. Install the crt implosion shield and frame using two 7/8 in. Torx-head screws.
14. Check that the graticule illumination light bulbs are in place in the light pipe at the bottom of the crt.

BNC Connectors (Vertical Inputs)

To replace BNC Connectors:

1. Remove the Main board (see Main board removal procedure).

NOTE

Do not disconnect the ends of the delay line from board as indicated in the Main board removal procedure. It is not necessary for replacing the input BNC connectors.

2. Using a 9/16 open-end wrench, remove and replace the defective BNC connector(s).
3. Replace the Main board (see Main board installation procedure).

A15 DAC Subsystem Board

To remove the DAC Subsystem board:

1. Unplug ribbon cables from connectors J2604 and J2601 (on Processor board).
2. Remove the four Torx-head attaching screws.

3. Remove the DAC Subsystem board from the instrument.

To install the DAC Subsystem board:

1. Position the board to align the screw holes and install the four Torx-head attaching screws (two 5/8 in. screws in the center and one 7/16 in. screw at each corner).
2. Plug ribbon cables into J2604 and J2601. Press the ribbon cable pins firmly into the connector holes.

A16 Processor Board

To remove the Processor board:

1. Unplug ribbon cables from Processor board connectors J1901, J2302, J2501, J2502, and J2601; unplug wire from J1902. To aid the release of the ribbon-cable pins from connector, slide a thin-shafted, flat-bladed screwdriver between the ribbon cable (near the connector) and the connector and pry gently upward.
2. Remove the six Torx-head attaching screws (one at each corner and two in the middle).
3. Unplug the ribbon cable from J2501 on the Potentiometer board. Lift the Processor board out of the instrument.

To install the Processor board:



Do not exceed 9 in-lb of torque when tightening the 6-32 screws that hold the circuit board to the chassis. Damage to the circuit board and/or screw threads may result if the screws are overtightened.

4. Position the board to align the screw holes and install the six Torx-head attaching screws (two 5/8 in. screws in the center and one 7/16 in. screw at each corner).
5. Plug in the ribbon cables that were removed in steps 1 and 3. Press the ribbon cable pins firmly into the connector holes.

A18 Power Supply Board

To remove the Power Supply board:

1. Remove the Processor board (see Processor board removal procedure).

WARNING

To avoid electrical shock, carefully discharge the crt anode lead directly to the metal chassis. To avoid static-discharge damage to electronic components, do not allow the anode lead to discharge into the adjacent circuitry.

2. Disconnect the high-voltage anode lead. Pull the anode-lead coupler apart slowly and carefully. DO NOT touch the exposed connector pin as it is withdrawn from coupler socket. Discharge the exposed anode pin to the metal chassis only. A hole is provided in the left side of the power supply chassis for the purpose of holding the end of the lead to prevent a recharge while it is disconnected.
3. Remove the eight screws holding the power supply housing shield and remove the shield.
4. Disconnect the connectors from J2208 and J2225 and the two wires from ac-line filter. (Note the color stripes on the wires to the line filter for reinstallation.)
5. Pull the HV connector through the grommet in the power supply housing.
6. Set the POWER switch in the OFF (out) position.

CAUTION

The POWER switch must be in the OFF position to safely remove the shaft from the shaft of the switch in the following step. Pulling the shaft off with the POWER switch on may damage the switch shaft and spring assembly.

7. Remove the power-switch-extension shaft. Snap the extension shaft off the transitional pivot assembly, then pull the shaft off the switch.
8. Remove the six screws that hold down the Power Supply board.

9. Unplug the Power Supply board from the Main board interface connector. Grasp the two heat sinks near the center of the board, one with each hand, and pull up to disconnect the interface connection.
10. Lift the front of Power Supply board and withdraw the board from the power-supply housing.

To install the Power Supply board:

11. Place the Power Supply board into power-supply housing. First, guide the fuse holder into the rear panel, then lower the front end of the board until the board interface pins touch the interface connector.
12. Plug the interface pins into the interface connector. With the Power Supply board against the rear panel, pull up on the large electrolytic capacitor (near the center of the board) with one hand and push down on HV multiplier module (at front of board) with the other hand. This action tends to align the pins with the connector. At the same time you will have to move the board around slightly so that the pins will easily slide into the connector holes. DO NOT FORCE this connection, otherwise you may bend the pins.

CAUTION

Do not exceed 9 in-lb of torque when tightening the 6-32 screws that hold the circuit board to the chassis. Damage to the circuit board or screw threads may result if the screws are overtightened.

13. Secure the circuit board with six screws.
14. Install the power-switch-extension shaft. Snap the shaft onto the switch, then onto the transitional pivot assembly.
15. Insert the high-voltage lead through the power-supply-housing grommet and snap the connector shell into the clamp at the front of the power-supply housing.
16. Connect the leads to J2208, J2225, and the ac-line filter (observe the color coding noted when the filter leads were disconnected).
17. Install the power-supply-housing shield with eight screws.
18. Connect the crt anode lead to the HV connector.

19. Install the Processor board (see Processor board installation instructions).

Potentiometer/Switch board Assembly

To remove the Potentiometer/Switch board assembly:

1. Unplug ribbon-cable connector P2501 from the Processor board and unplug ribbon-cable connector P2105 from the Potentiometer board.
2. Remove the CH 1 and CH 2 VOLTS/DIV VAR knobs and the SEC/DIV VAR knob. (A 1/16 in. hexagonal wrench is needed for the set screws).
3. Pull out all the remaining front-panel knobs to the right of the crt. Grasp the knobs firmly and pull straight out from the front panel.
4. Pull out on the four captive plastic snap fasteners on the back of the switch board that hold the Switch board assembly to the front panel (not those that hold the Potentiometer board to the Switch board). Use long-nose pliers as necessary to reach the fasteners.
5. Unclip the high-voltage connector from the front of the power-supply housing. Remove the plastic retaining clip from the housing (it is pressed in). Move the high-voltage connector to the top of the power-supply housing to make room for removing the Potentiometer/Switch board.
6. Move the Potentiometer/Switch board assembly back away from the front panel and lift it out of the instrument.

To separate the A12 Potentiometer board from the Switch board:

7. Pull out on the three snap fasteners that hold the Potentiometer board to the Switch board.
8. Separate the Potentiometer board from the Switch board.
9. If necessary, unplug the VAR control shafts from their potentiometers.

To install the Potentiometer board:

10. Set the three snap fasteners on the board in the released (out) position.

11. Plug the three VAR control shafts onto the VAR potentiometers.

12. Set the Potentiometer board in place over the Switch board and press in on the snap fasteners.

To install the Potentiometer/Switch board assembly:

13. Set the four snap fasteners (on the Switch board) in the released (out) position.
14. Guide the Potentiometer/Switch board assembly into place behind the front panel and press in on the snap fasteners.
15. Install the control knobs. Push knobs in while rotating slightly until they align with the shaft and snap in place. The two knobs without a position-indicator rib go on the ← and → control shafts.
16. Install the three VAR control knobs, using 1/16 in. allen wrench. Make sure that VAR controls are in the detent (fully CW) position, then rotate the knobs so that the VAR label is horizontal before tightening the set screws.
17. Install the high-voltage connector clip to the front side of the power-supply housing and snap the connector shell into it.
18. Connect ribbon cable J2105 to the Potentiometer board and P2501 to the Processor board. Position the connector pins in the socket holes and push them fully into place.

A10 Main Board

NOTE

This procedure is intended for the complete replacement of the Main board. Most repairs and component replacements can be done without completely removing the Main board. When replacing BNC connectors, use the BNC Connector replacement procedure previously given in this section.

To remove the Main board:

1. Remove the crt (see crt removal procedure).
2. Pull out and remove the five crt-display control knobs.

3. Remove the Processor board (see Processor board removal procedure).
4. Remove the shield from the power-supply housing (held with eight screws).
5. Unplug the three-wire cable from J2208 on the Power Supply board. Pull the cable and connector through the plastic grommet.
6. Release the crt socket from its holder on the rear panel. First pull off clear plastic socket retainer, then push the socket out the rear enough to turn it sideways and push it through to the inside of the instrument.
7. Remove the Potentiometer/Switch board assembly (see Potentiometer/Switch board assembly removal procedure).
8. Remove the top and bottom attenuator shields. The bottom shield is held with 5 screws and the top shield is held with one remaining screw. See Figure 6-4.

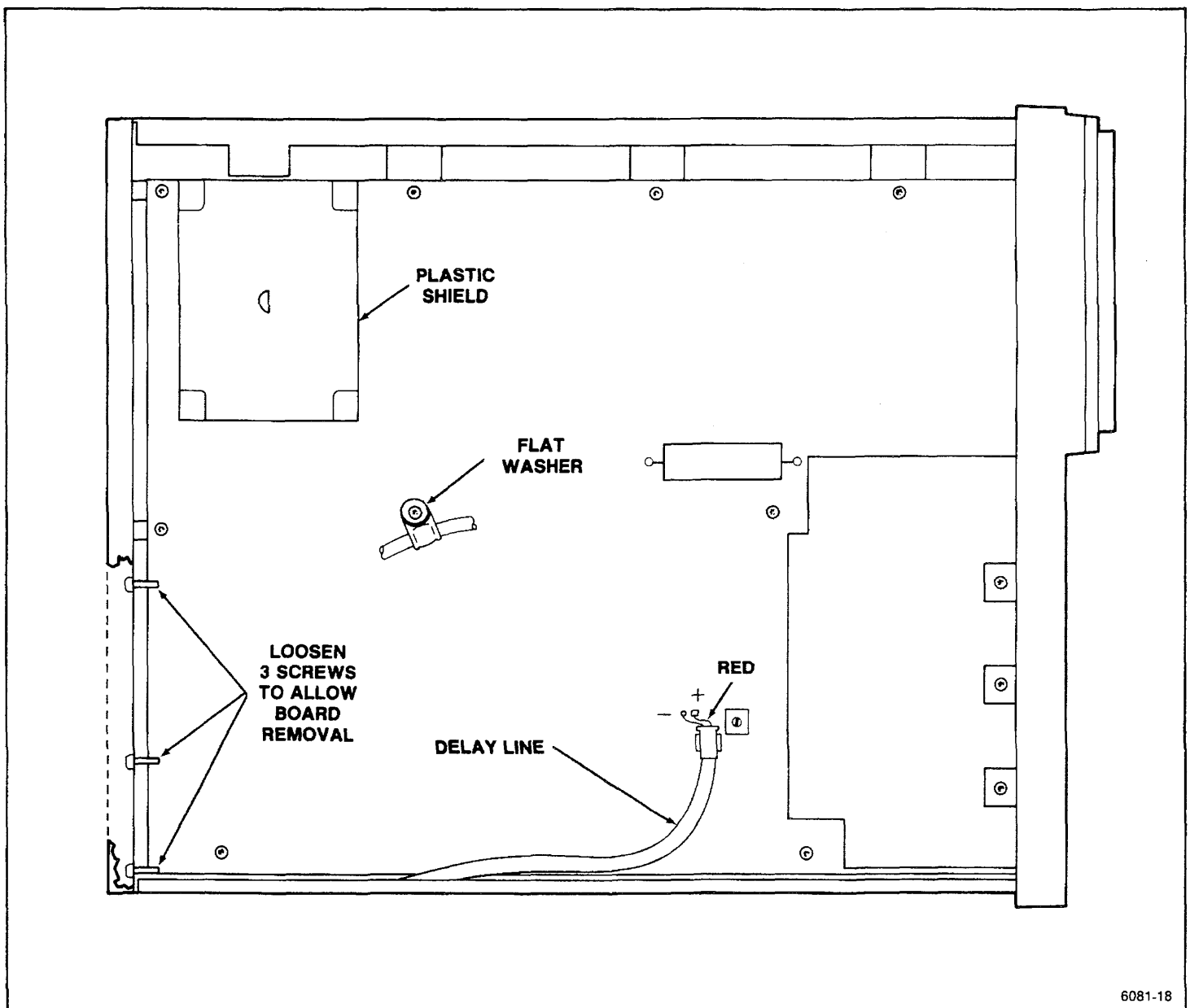

Figure 6-4. Main board removal.

NOTE

If the Main board is being removed to replace or repair a component (such as a BNC connector), it is not necessary to disconnect the delay line from the board as indicated in the following step.

9. Unsolder the main delay-line wires from both sides of board (see Figures 6-4 and 6-5).

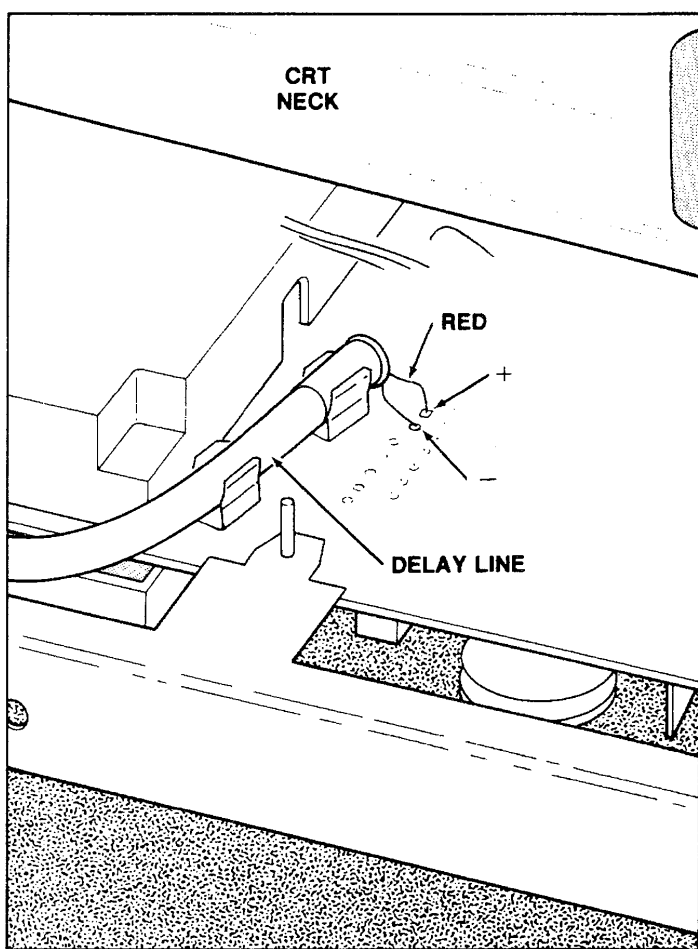

Figure 6-5. Delay-line connections to top of Main board.

10. Unclip the delay line from both sides of the board and from the two clips at the lower side of the rear panel. Remove the two clips from the rear panel.
11. Remove the ten screws that hold the Main board to the chassis. Back out the three screws going through the rear panel enough to allow removal of Main board. See Figure 6-4.

12. Pull the three ribbon cables through to the bottom of the instrument.
13. Lift the back of main board enough to disconnect interface connection between Main board and Power Supply board.
14. Slide the Main board back away from front panel to completely remove the board from the instrument.

To install the Main board:

15. Guide the BNC connectors at front of the Main board into the holes in the front panel. Make sure that you guide the PROBE ADJUST jack into the front panel as well as the BNC connectors.
16. Lower the rear of Main board while guiding the interface connector onto the power supply interface pins. **DO NOT FORCE** this connection; the pins may bend. Make sure that the grommet holding the crt and power supply wires is in place between the board and the rear panel.



Do not exceed 9 in-lb of torque when tightening the 6-32 screws that hold the circuit board to the chassis. Damage to the circuit board or screw threads may result if the screws are overtightened.

17. Secure the Main board with ten screws. See Figure 6-4.
18. Solder both ends of delay line to Main board. Be sure to observe the polarity of the leads. See Figures 6-4 and 6-5. Press the ends of delay line into the clips on board.
19. Snap the two plastic clips into the lower edge of the rear panel and snap the delay line into them.
20. Connect the three-wire cable from the crt-socket cable assembly to J2208 on the Power Supply board.
21. Install the shield on the power-supply housing (eight screws).
22. Install the inside attenuator shield (secure with one screw). Then install the outside attenuator shield (secure with five screws).

Maintenance – 2247A Service

23. Install the Potentiometer/Switch board assembly (see Potentiometer/Switch board assembly installation procedure).
24. Install the Processor board.
25. Dress the two ribbon cables to the top of the instrument. Connect them to the Processor and Potentiometer boards.
26. Install the crt socket. Turn the socket sideways and push it through the crt-socket holder in the rear panel.
27. Install the crt (see crt installation procedure).

OPTIONS

INTRODUCTION

This section contains a general description of the instrument options available at the time of publication. Additional information about instrument options can be obtained either by consulting the current Tektronix Product Catalog or by contacting your local Tektronix Field Office or representative.

INTERNATIONAL POWER CORDS

Instruments are shipped with the detachable power-cord option ordered by the customer. Descriptive information about the international power-cord options is provided in Section 2 "Preparation for Use." The following list describes the power cords available for the 2247A.

Standard	North American 120 V, 60 Hz, 74 in.
Option A1	Universal Euro 220 V, 50 Hz, 2.5 m
Option A2	UK 240 V, 50 Hz, 2.5 m
Option A3	Australian 240 V, 50 Hz, 2.5 m
Option A4	North American 240 V, 50 Hz, 2.5 m
Option A5	Switzerland 220 V, 50 Hz, 2.5 m

OPTION 1R RACKMOUNTED INSTRUMENT

When the 2247A Portable Oscilloscope is ordered with Option 1R, it is shipped in a configuration that permits easy installation into a 19-inch-wide equipment rack. Also, an optional rackmounting kit may be ordered to convert the standard 2247A to a rackmounted instrument. Installation instructions for rackmounting are provided in the documentation supplied with the rackmounting kit and the 1R Option.

OTHER AVAILABLE OPTIONS

Option 02	Front Panel Cover and Accessory Pouch
Option 1C	C-5C Option 02 Camera
Option 1K	K212 Portable Instrument Cart
Option 17	P6408 Logic Probe included
Option 22	Two P6109 Option 1 10X voltage probes
Option 23	Two P6062B 1X/10X voltage probes, 6 feet

*This Document is a complete Scan from the original
Tektronix manual*

*For enquiries about our complete
High quality line of technical Manuals in PDF*

mailto : Qservice@otenet.gr

**SEE
OTHER
SIDE**

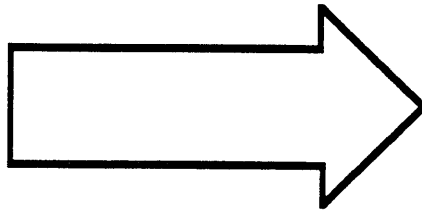

REPLACEABLE ELECTRICAL PARTS

PARTS ORDERING INFORMATION

Replacement parts are available from or through your local Tektronix, Inc. Field Office or representative.

Changes to Tektronix instruments are sometimes made to accommodate improved components as they become available, and to give you the benefit of the latest circuit improvements developed in our engineering department. It is therefore important, when ordering parts, to include the following information in your order: Part number, instrument type or number, serial number, and modification number if applicable.

If a part you have ordered has been replaced with a new or improved part, your local Tektronix, Inc. Field Office or representative will contact you concerning any change in part number.

Change information, if any, is located at the rear of this manual.

Only the circuit number will appear on the diagrams and circuit board illustrations. Each diagram and circuit board illustration is clearly marked with the assembly number. Assembly numbers are also marked on the mechanical exploded views located in the Mechanical Parts List. The component number is obtained by adding the assembly number prefix to the circuit number.

The Electrical Parts List is divided and arranged by assemblies in numerical sequence (e.g., assembly A1 with its subassemblies and parts, precedes assembly A2 with its subassemblies and parts).

Chassis-mounted parts have no assembly number prefix and are located at the end of the Electrical Parts List.

LIST OF ASSEMBLIES

A list of assemblies can be found at the beginning of the Electrical Parts List. The assemblies are listed in numerical order. When the complete component number of a part is known, this list will identify the assembly in which the part is located.

CROSS INDEX-MFR. CODE NUMBER TO MANUFACTURER

The Mfr. Code Number to Manufacturer index for the Electrical Parts List is located immediately after this page. The Cross Index provides codes, names and addresses of manufacturers of components listed in the Electrical Parts List.

ABBREVIATIONS

Abbreviations conform to American National Standard Y1.1.

COMPONENT NUMBER (column one of the Electrical Parts List)

A numbering method has been used to identify assemblies, subassemblies and parts. Examples of this numbering method and typical expansions are illustrated by the following:

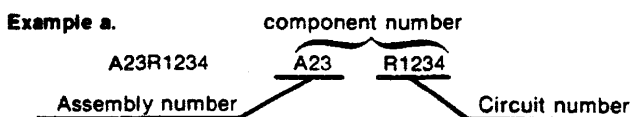

Read: Resistor 1234 of Assembly 23

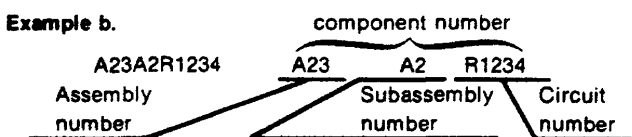

Read: Resistor 1234 of Subassembly 2 of Assembly 23

TEKTRONIX PART NO. (column two of the Electrical Parts List)

Indicates part number to be used when ordering replacement part from Tektronix.

SERIAL/MODEL NO. (columns three and four of the Electrical Parts List)

Column three (3) indicates the serial number at which the part was first used. Column four (4) indicates the serial number at which the part was removed. No serial number entered indicates part is good for all serial numbers.

NAME & DESCRIPTION (column five of the Electrical Parts List)

In the Parts List, an Item Name is separated from the description by a colon (:). Because of space limitations, an Item Name may sometimes appear as incomplete. For further Item Name identification, the U.S. Federal Cataloging Handbook H6-1 can be utilized where possible.

MFR. CODE (column six of the Electrical Parts List)

Indicates the code number of the actual manufacturer of the part. (Code to name and address cross reference can be found immediately after this page.)

MFR. PART NUMBER (column seven of the Electrical Parts List)

Indicates actual manufacturers part number.

CROSS INDEX - MFR. CODE NUMBER TO MANUFACTURER

Mfr. Code	Manufacturer	Address	City, State, Zip Code
00136	MCCOY ELECTRONICS CO	100 WATTS ST PO BOX B	MT HOLLY SPRINGS PA 17065-1821
00779	AMP INC	2800 FULLING MILL PO BOX 3608	HARRISBURG PA 17105
01121	ALLEN-BRADLEY CO	1201 S 2ND ST	MILWAUKEE WI 53204-2410
01295	TEXAS INSTRUMENTS INC SEMICONDUCTOR GROUP	13500 N CENTRAL EXPY PO BOX 655012	DALLAS TX 75265
02114	AMPEREX ELECTRONIC CORP FERROXCUBE DIV	5083 KINGS HWY	SAUGERTIES NY 12477
02735	RCA CORP SOLID STATE DIVISION	ROUTE 202	SOMERVILLE NJ 08876
03508	GENERAL ELECTRIC CO SEMI-CONDUCTOR PRODUCTS DEPT	W GENESEE ST	AUBURN NY 13021
04222	AVX CERAMICS DIV OF AVX CORP	19TH AVE SOUTH P O BOX 867	MYRTLE BEACH SC 29577
04713	MOTOROLA INC SEMICONDUCTOR PRODUCTS SECTOR	5005 E MCDOWELL RD	PHOENIX AZ 85008-4229
05397	UNION CARBIDE CORP MATERIALS SYSTEMS DIV	11901 MADISON AVE	CLEVELAND OH 44101
05828	GENERAL INSTRUMENT CORP GOVERNMENT SYSTEMS DIV	600 W JOHN ST	HICKSVILLE NY 11802
06665	PRECISION MONOLITHICS INC SUB OF BOURNS INC	1500 SPACE PARK DR	SANTA CLARA CA 95050
08806	GENERAL ELECTRIC CO MINIATURE LAMP PRODUCTS DEPT LIGHTING BUSINESS GROUP	NELA PK	CLEVELAND OH 44112
09922	BURNDY CORP	RICHARDS AVE	NORWALK CT 06852
11236	CTS CORP BERNE DIV THICK FILM PRODUCTS GROUP	406 PARR ROAD	BERNE IN 46711-9506
14433	ITT SEMICONDUCTORS DIV		WEST PALM BEACH FL
14552	MICROSEMI CORP	2830 S FAIRVIEW ST	SANTA ANA CA 92704-5948
19701	MEPCO/CENTRALAB A NORTH AMERICAN PHILIPS CO MINERAL WELLS AIRPORT	PO BOX 760	MINERAL WELLS TX 76067-0760
24546	CORNING GLASS WORKS	550 HIGH ST	BRADFORD PA 16701-3737
24931	SPECIALTY CONNECTOR CO INC	2100 EARLYWOOD DR PO BOX 547	FRANKLIN IN 46131
27014	NATIONAL SEMICONDUCTOR CORP	2900 SEMICONDUCTOR DR	SANTA CLARA CA 95051-0606
32997	BOURNS INC TRIMPOT DIV	1200 COLUMBIA AVE	RIVERSIDE CA 92507-2114
34335	ADVANCED MICRO DEVICES	901 THOMPSON PL	SUNNYVALE CA 94086-4518
50434	HEWLETT-PACKARD CO OPTOELECTRONICS DIV	370 W TRIMBLE RD	SAN JOSE CA 95131
51642	CENTRE ENGINEERING INC	2820 E COLLEGE AVE	STATE COLLEGE PA 16801-7515
52763	STETCO INC	3344 SCHIERHORN	FRANKLIN PARK IL 60131
52769	SPRAGUE-GOODMAN ELECTRONICS INC	134 FULTON AVE	GARDEN CITY PARK NY 11040-5352
54473	MATSUSHITA ELECTRIC CORP OF AMERICA	ONE PANASONIC WAY PO BOX 1501	SECAUCUS NJ 07094-2917
54583	TDK ELECTRONICS CORP	12 HARBOR PARK DR	PORT WASHINGTON NY 11550
55680	NICHICON /AMERICA/ CORP	927 E STATE PKY	SCHAUMBURG IL 60195-4526
56289	SPRAGUE ELECTRIC CO WORLD HEADQUARTERS	92 HAYDEN AVE	LEXINGTON MA 02173-7929
57668	ROHM CORP	8 WHATNEY PO BOX 19515	IRVINE CA 92713
59660	TUSONIX INC	7741 N BUSINESS PARK DR PO BOX 37144	TUCSON AZ 85740-7144
71400	BUSSMANN DIV OF COOPER INDUSTRIES INC	114 OLD STATE RD PO BOX 14460	ST LOUIS MO 63178
71590	CRL COMPONENTS INC	HWY 20 W PO BOX 858	FORT DODGE IA 50501
75042	IRC ELECTRONIC COMPONENTS PHILADELPHIA DIV TRW FIXED RESISTORS	401 N BROAD ST	PHILADELPHIA PA 19108-1001
80009	TEKTRONIX INC	14150 SW KARL BRAUN DR PO BOX 500	BEAVERTON OR 97077-0001

CROSS INDEX - MFR. CODE NUMBER TO MANUFACTURER

Mfr. Code	Manufacturer	Address	City, State, Zip Code
91637	DALE ELECTRONICS INC	2064 12TH AVE PO BOX 609	COLUMBUS NE 68601-3632
TK0961	NEC ELECTRONICS USA INC ELECTRON DIV	401 ELLIS ST PO BOX 7241	MOUNTAIN VIEW CA 94039
TK1650	AMP INC	19200 STEVENS CREEK BLVD SUITE 100	CUPERTINO CA 95014

Replaceable Electrical Parts - 2247A Service

Component No.	Tektronix Part No.	Serial/Assembly No. Effective	Dscont	Name & Description	Mfr. Code	Mfr. Part No.
A8	670-9783-01			CIRCUIT BD ASSY:CRT CONTROL	80009	670-9783-01
A10	671-0422-00	B010100	B010599	CIRCUIT BD ASSY:MAIN	80009	671-0422-00
A10	671-0422-01	B010600	B020178	CIRCUIT BD ASSY:MAIN	80009	671-0422-01
A10	671-0422-02	B020179		CIRCUIT BD ASSY:A10 MAIN	80009	671-0422-02
A12	672-0262-00			CIRCUIT BD ASSY:FRONT PANEL MODULE	80009	672-0262-00
A12A12	670-9402-01			CIRCUIT BD ASSY:POTENTIOMETER	80009	670-9402-01
A12A14	670-9399-01			CIRCUIT BD ASSY:SWITCH	80009	670-9399-01
A15	671-0247-00			CIRCUIT BD ASSY:DAC SUBSYS	80009	671-0247-00
A16	671-0812-00	B010100	B010515	CIRCUIT BD ASSY:PROCESSOR	80009	671-0812-00
A16	671-0812-01	B010516		CIRCUIT BD ASSY:PROCESSOR (DOES NOT INCLUDE U2519)	80009	671-0812-01
A16	672-0247-00	B010100	B010515	CIRCUIT BD ASSY:PROCESSOR	80009	672-0247-00
A16	672-0247-01	B010516		CIRCUIT BD ASSY:PROCESSOR (INCLUDES U2519)	80009	672-0247-01
A18	670-9398-04			CIRCUIT BD ASSY:LV POWER SUPPLY	80009	670-9398-04
A8	670-9783-01			CIRCUIT BD ASSY:CRT CONTROL	80009	670-9783-01
A8R901	311-2344-00			RES,VAR, NONWw:CKT BD,4.7K OHM,20%,1.25W	71590	BA17140001
A8R902	311-2344-00			RES,VAR, NONWw:CKT BD,4.7K OHM,20%,1.25W	71590	BA17140001
A8R903	311-2344-00			RES,VAR, NONWw:CKT BD,4.7K OHM,20%,1.25W	71590	BA17140001
A8R905	311-2344-00			RES,VAR, NONWw:CKT BD,4.7K OHM,20%,1.25W	71590	BA17140001
A8W900	131-4038-00			CONN,RCPT,ELEC:HDR,1 X 8,RTANG,0.1 SPACING	00779	640453-8
A10	671-0422-00	B010100	B010599	CIRCUIT BD ASSY:MAIN	80009	671-0422-00
A10	671-0422-01	B010600	B020178	CIRCUIT BD ASSY:MAIN	80009	671-0422-01
A10	671-0422-02	B020179		CIRCUIT BD ASSY:A10 MAIN	80009	671-0422-02
A10AT117	307-2135-01			ATTENUATOR:1M OHM ATTENUATOR NETWORK	80009	307-2135-01
A10AT127	307-2135-01			ATTENUATOR:1M OHM ATTENUATOR NETWORK	80009	307-2135-01
A10C101	281-0909-00			CAP,FXD,CER DI:0.022UF,20%,50V	54583	MA12X7R1H223M-T
A10C102	281-0909-00			CAP,FXD,CER DI:0.022UF,20%,50V	54583	MA12X7R1H223M-T
A10C103	281-0909-00			CAP,FXD,CER DI:0.022UF,20%,50V	54583	MA12X7R1H223M-T
A10C104	281-0909-00			CAP,FXD,CER DI:0.022UF,20%,50V	54583	MA12X7R1H223M-T
A10C105	281-0909-00			CAP,FXD,CER DI:0.022UF,20%,50V	54583	MA12X7R1H223M-T
A10C106	281-0909-00			CAP,FXD,CER DI:0.022UF,20%,50V	54583	MA12X7R1H223M-T
A10C107	281-0909-00			CAP,FXD,CER DI:0.022UF,20%,50V	54583	MA12X7R1H223M-T
A10C108	281-0909-00			CAP,FXD,CER DI:0.022UF,20%,50V	54583	MA12X7R1H223M-T
A10C111	281-0909-00			CAP,FXD,CER DI:0.022UF,20%,50V	54583	MA12X7R1H223M-T
A10C112	283-0414-01			CAP,FXD,CER DI:0.022UF,20%,500V	80009	283-0414-01
A10C113	281-0909-00			CAP,FXD,CER DI:0.022UF,20%,50V	54583	MA12X7R1H223M-T
A10C114	281-0214-00			CAP,VAR,CER DI:0.6-3PF,400V	52763	313613-140
A10C121	281-0909-00			CAP,FXD,CER DI:0.022UF,20%,50V	54583	MA12X7R1H223M-T
A10C122	283-0414-01			CAP,FXD,CER DI:0.022UF,20%,500V	80009	283-0414-01
A10C123	281-0909-00			CAP,FXD,CER DI:0.022UF,20%,50V	54583	MA12X7R1H223M-T
A10C124	281-0214-00			CAP,VAR,CER DI:0.6-3PF,400V	52763	313613-140
A10C125	281-0770-00			CAP,FXD,CER DI:1000PF,20%,100V	04222	MA101C102MAA
A10C126	281-0770-00			CAP,FXD,CER DI:1000PF,20%,100V	04222	MA101C102MAA
A10C131	281-0909-00			CAP,FXD,CER DI:0.022UF,20%,50V	54583	MA12X7R1H223M-T
A10C132	281-0938-00			CAP,FXD,CER DI:20PF,2%,500V	04222	MA107A200GAA
A10C133	281-0799-00			CAP,FXD,CER DI:62PF,2%,100V	04222	MA101A620GAA
A10C134	281-0306-00			CAP,VAR,CER DI:3.3-20PF	52769	GKU 18000
A10C135	281-0909-00			CAP,FXD,CER DI:0.022UF,20%,50V	54583	MA12X7R1H223M-T
A10C136	281-0909-00			CAP,FXD,CER DI:0.022UF,20%,50V	54583	MA12X7R1H223M-T
A10C137	281-0797-00			CAP,FXD,CER DI:15PF,10%,100V	04222	SA106A150KAA
A10C138	281-0315-00			CAP,VAR,CER DI:2.8-10PF	52769	GKU 10000
A10C139	281-0797-00			CAP,FXD,CER DI:15PF,10%,100V	04222	SA106A150KAA
A10C140	290-0974-01			CAP,FXD,ELCTLT:10UF,20%,50V	55680	UVX1H100MAA1TA

Component No.	Tektronix Part No.	Serial/Assembly No. Effective Dscnt	Name & Description	Mfr. Code	Mfr. Part No.
A10C151	281-0909-00		CAP, FXD, CER DI: 0.022UF, 20%, 50V	54583	MA12X7R1H223M-T
A10C152	281-0938-00		CAP, FXD, CER DI: 20PF, 2%, 500V	04222	MA107A200GAA
A10C153	281-0799-00		CAP, FXD, CER DI: 62PF, 2%, 100V	04222	MA101A620GAA
A10C154	281-0306-00		CAP, VAR, CER DI: 3.3-20PF	52769	GPU 18000
A10C155	281-0909-00		CAP, FXD, CER DI: 0.022UF, 20%, 50V	54583	MA12X7R1H223M-T
A10C156	281-0909-00		CAP, FXD, CER DI: 0.022UF, 20%, 50V	54583	MA12X7R1H223M-T
A10C157	281-0797-00		CAP, FXD, CER DI: 15PF, 10%, 100V	04222	SA106A150KAA
A10C158	281-0315-00		CAP, VAR, CER DI: 2.8-10PF	52769	GPU 10000
A10C159	281-0797-00		CAP, FXD, CER DI: 15PF, 10%, 100V	04222	SA106A150KAA
A10C171	290-0974-01		CAP, FXD, ELCTLT: 10UF, 20%, 50V	55680	UVX1H100MAA1TA
A10C172	281-0909-00		CAP, FXD, CER DI: 0.022UF, 20%, 50V	54583	MA12X7R1H223M-T
A10C173	281-0772-00		CAP, FXD, CER DI: 4700PF, 10%, 100V	04222	MA201C472KAA
A10C180	290-0944-01		CAP, FXD, ELCTLT: 220UF, 20%, 10V	55680	UVX1C221MPA1TA
A10C181	290-0944-01		CAP, FXD, ELCTLT: 220UF, 20%, 10V	55680	UVX1C221MPA1TA
A10C190	281-0797-00		CAP, FXD, CER DI: 15PF, 10%, 100V	04222	SA106A150KAA
A10C191	281-0797-00		CAP, FXD, CER DI: 15PF, 10%, 100V	04222	SA106A150KAA
A10C201	290-0974-01		CAP, FXD, ELCTLT: 10UF, 20%, 50V	55680	UVX1H100MAA1TA
A10C202	290-0974-01		CAP, FXD, ELCTLT: 10UF, 20%, 50V	55680	UVX1H100MAA1TA
A10C203	290-0974-01		CAP, FXD, ELCTLT: 10UF, 20%, 50V	55680	UVX1H100MAA1TA
A10C204	290-0974-01		CAP, FXD, ELCTLT: 10UF, 20%, 50V	55680	UVX1H100MAA1TA
A10C205	281-0909-00		CAP, FXD, CER DI: 0.022UF, 20%, 50V	54583	MA12X7R1H223M-T
A10C206	281-0909-00		CAP, FXD, CER DI: 0.022UF, 20%, 50V	54583	MA12X7R1H223M-T
A10C210	281-0909-00		CAP, FXD, CER DI: 0.022UF, 20%, 50V	54583	MA12X7R1H223M-T
A10C211	281-0759-00		CAP, FXD, CER DI: 22PF, 10%, 100V	04222	MA101A220KAA
A10C212	281-0909-00		CAP, FXD, CER DI: 0.022UF, 20%, 50V	54583	MA12X7R1H223M-T
A10C213	281-0909-00		CAP, FXD, CER DI: 0.022UF, 20%, 50V	54583	MA12X7R1H223M-T
A10C214	281-0909-00		CAP, FXD, CER DI: 0.022UF, 20%, 50V	54583	MA12X7R1H223M-T
A10C215	290-0974-01		CAP, FXD, ELCTLT: 10UF, 20%, 50V	55680	UVX1H100MAA1TA
A10C216	281-0909-00		CAP, FXD, CER DI: 0.022UF, 20%, 50V	54583	MA12X7R1H223M-T
A10C217	281-0909-00		CAP, FXD, CER DI: 0.022UF, 20%, 50V	54583	MA12X7R1H223M-T
A10C218	281-0775-01		CAP, FXD, CER DI: 0.1UF, 20%, 50V	04222	SA105E104MAA
A10C219	281-0909-00		CAP, FXD, CER DI: 0.022UF, 20%, 50V	54583	MA12X7R1H223M-T
A10C220	281-0909-00		CAP, FXD, CER DI: 0.022UF, 20%, 50V	54583	MA12X7R1H223M-T
A10C221	281-0759-00		CAP, FXD, CER DI: 22PF, 10%, 100V	04222	MA101A220KAA
A10C222	281-0909-00		CAP, FXD, CER DI: 0.022UF, 20%, 50V	54583	MA12X7R1H223M-T
A10C223	281-0909-00		CAP, FXD, CER DI: 0.022UF, 20%, 50V	54583	MA12X7R1H223M-T
A10C224	281-0909-00		CAP, FXD, CER DI: 0.022UF, 20%, 50V	54583	MA12X7R1H223M-T
A10C225	290-0974-01		CAP, FXD, ELCTLT: 10UF, 20%, 50V	55680	UVX1H100MAA1TA
A10C228	281-0775-01		CAP, FXD, CER DI: 0.1UF, 20%, 50V	04222	SA105E104MAA
A10C229	281-0909-00		CAP, FXD, CER DI: 0.022UF, 20%, 50V	54583	MA12X7R1H223M-T
A10C232	281-0909-00		CAP, FXD, CER DI: 0.022UF, 20%, 50V	54583	MA12X7R1H223M-T
A10C233	281-0909-00		CAP, FXD, CER DI: 0.022UF, 20%, 50V	54583	MA12X7R1H223M-T
A10C234	281-0909-00		CAP, FXD, CER DI: 0.022UF, 20%, 50V	54583	MA12X7R1H223M-T
A10C235	290-0974-01		CAP, FXD, ELCTLT: 10UF, 20%, 50V	55680	UVX1H100MAA1TA
A10C238	281-0775-01		CAP, FXD, CER DI: 0.1UF, 20%, 50V	04222	SA105E104MAA
A10C239	281-0909-00		CAP, FXD, CER DI: 0.022UF, 20%, 50V	54583	MA12X7R1H223M-T
A10C242	281-0909-00		CAP, FXD, CER DI: 0.022UF, 20%, 50V	54583	MA12X7R1H223M-T
A10C243	281-0909-00		CAP, FXD, CER DI: 0.022UF, 20%, 50V	54583	MA12X7R1H223M-T
A10C244	281-0909-00		CAP, FXD, CER DI: 0.022UF, 20%, 50V	54583	MA12X7R1H223M-T
A10C245	290-0974-01		CAP, FXD, ELCTLT: 10UF, 20%, 50V	55680	UVX1H100MAA1TA
A10C248	281-0775-01		CAP, FXD, CER DI: 0.1UF, 20%, 50V	04222	SA105E104MAA
A10C249	281-0909-00		CAP, FXD, CER DI: 0.022UF, 20%, 50V	54583	MA12X7R1H223M-T
A10C258	290-0974-01		CAP, FXD, ELCTLT: 10UF, 20%, 50V	55680	UVX1H100MAA1TA
A10C265	281-0909-00		CAP, FXD, CER DI: 0.022UF, 20%, 50V	54583	MA12X7R1H223M-T
A10C268	281-0770-00		CAP, FXD, CER DI: 1000PF, 20%, 100V	04222	MA101C102MAA
A10C271	281-0798-00		CAP, FXD, CER DI: 51PF, 1%, 100V	04222	MA101A510GAA
A10C272	281-0819-00		CAP, FXD, CER DI: 33 PF, 5%, 50V	04222	GC105A33QJ
A10C273	281-0307-00		CAP, VAR, CER DI: 3-8-25PF	52769	GPU 25000

Replaceable Electrical Parts - 2247A Service

Component No.	Tektronix Part No.	Serial/Assembly No. Effective	Dscont	Name & Description	Mfr. Code	Mfr. Part No.
A10C274	281-0305-00			CAP, VAR, CER DI: 1.5-4.0PF	52769	GKU 4R000
A10C275	281-0872-00			CAP, FXD, CER DI: 91PF, 5%, 100V	04222	MC101A910J
A10C282	281-0909-00			CAP, FXD, CER DI: 0.022UF, 20%, 50V	54583	MA12X7R1H223M-T
A10C283	281-0909-00			CAP, FXD, CER DI: 0.022UF, 20%, 50V	54583	MA12X7R1H223M-T
A10C297	281-0909-00			CAP, FXD, CER DI: 0.022UF, 20%, 50V	54583	MA12X7R1H223M-T
A10C298	281-0909-00			CAP, FXD, CER DI: 0.022UF, 20%, 50V	54583	MA12X7R1H223M-T
A10C301	281-0909-00			CAP, FXD, CER DI: 0.022UF, 20%, 50V	54583	MA12X7R1H223M-T
A10C302	281-0770-00			CAP, FXD, CER DI: 1000PF, 20%, 100V	04222	MA101C102MAA
A10C303	290-0183-00			CAP, FXD, ELCTLT: 1UF, 10%, 35V	05397	T3228105K035AS
A10C304	281-0909-00			CAP, FXD, CER DI: 0.022UF, 20%, 50V	54583	MA12X7R1H223M-T
A10C305	290-0183-00			CAP, FXD, ELCTLT: 1UF, 10%, 35V	05397	T3228105K035AS
A10C306	290-0183-00			CAP, FXD, ELCTLT: 1UF, 10%, 35V	05397	T3228105K035AS
A10C307	295-0198-00			CAP SET, MATCHED: (1), 10.0UF, 1.5%, 25V/(1)0.1U F, 1.5%, 35V/(1)0.0099UF, 1.5%, 50V (LOCATION A, B, C)	80009	295-0198-00
A10C308	281-0909-00			CAP, FXD, CER DI: 0.022UF, 20%, 50V	54583	MA12X7R1H223M-T
A10C309	281-0909-00			CAP, FXD, CER DI: 0.022UF, 20%, 50V	54583	MA12X7R1H223M-T
A10C310	281-0909-00			CAP, FXD, CER DI: 0.022UF, 20%, 50V	54583	MA12X7R1H223M-T
A10C311	281-0798-00			CAP, FXD, CER DI: 51PF, 1%, 100V	04222	MA101A510GAA
A10C312	281-0909-00			CAP, FXD, CER DI: 0.022UF, 20%, 50V	54583	MA12X7R1H223M-T
A10C313	281-0909-00			CAP, FXD, CER DI: 0.022UF, 20%, 50V	54583	MA12X7R1H223M-T
A10C314	281-0307-00			CAP, VAR, CER DI: 3-8-25PF	52769	GKU 25000
A10C315	281-0798-00			CAP, FXD, CER DI: 51PF, 1%, 100V	04222	MA101A510GAA
A10C316	281-0909-00			CAP, FXD, CER DI: 0.022UF, 20%, 50V	54583	MA12X7R1H223M-T
A10C317	281-0909-00			CAP, FXD, CER DI: 0.022UF, 20%, 50V	54583	MA12X7R1H223M-T
A10C318	281-0909-00			CAP, FXD, CER DI: 0.022UF, 20%, 50V	54583	MA12X7R1H223M-T
A10C319	281-0909-00			CAP, FXD, CER DI: 0.022UF, 20%, 50V	54583	MA12X7R1H223M-T
A10C320	281-0909-00			CAP, FXD, CER DI: 0.022UF, 20%, 50V	54583	MA12X7R1H223M-T
A10C321	281-0798-00			CAP, FXD, CER DI: 51PF, 1%, 100V	04222	MA101A510GAA
A10C326	281-0909-00			CAP, FXD, CER DI: 0.022UF, 20%, 50V	54583	MA12X7R1H223M-T
A10C329	281-0307-00			CAP, VAR, CER DI: 3-8-25PF	52769	GKU 25000
A10C330	281-0799-00			CAP, FXD, CER DI: 62PF, 2%, 100V	04222	MA101A620GAA
A10C337	281-0909-00			CAP, FXD, CER DI: 0.022UF, 20%, 50V	54583	MA12X7R1H223M-T
A10C338	281-0909-00			CAP, FXD, CER DI: 0.022UF, 20%, 50V	54583	MA12X7R1H223M-T
A10C339	281-0909-00			CAP, FXD, CER DI: 0.022UF, 20%, 50V	54583	MA12X7R1H223M-T
A10C351	281-0909-00			CAP, FXD, CER DI: 0.022UF, 20%, 50V	54583	MA12X7R1H223M-T
A10C417	281-0915-00	B010600		CAP, FXD, CER DI: 1.8PF, +/-0.25PF, 200WVDC	04222	SA102A1R8CAA
A10C421	281-0775-01			CAP, FXD, CER DI: 0.1UF, 20%, 50V	04222	SA105E104MAA
A10C422	281-0861-00			CAP, FXD, CER DI: 270PF, 5%, 50V	04222	SA101A271JAA
A10C423	281-0864-00			CAP, FXD, CER DI: 430PF, 5%, 100V	54583	MA12C0G2A431J
A10C424	290-0183-00			CAP, FXD, ELCTLT: 1UF, 10%, 35V	05397	T3228105K035AS
A10C425	281-0820-00	B010100	B020178	CAP, FXD, CER DI: 680 PF, 10%, 50V	04222	SA101C681KAA
A10C425	281-0861-00	B020179		CAP, FXD, CER DI: 270PF, 5%, 50V	04222	SA101A271JAA
A10C426	281-0864-00			CAP, FXD, CER DI: 430PF, 5%, 100V	54583	MA12C0G2A431J
A10C432	281-0767-00			CAP, FXD, CER DI: 330PF, 20%, 100V	04222	MA106C331MAA
A10C442	281-0909-00			CAP, FXD, CER DI: 0.022UF, 20%, 50V	54583	MA12X7R1H223M-T
A10C444	281-0765-00			CAP, FXD, CER DI: 100PF, 5%, 100V	04222	MA101A101JAA
A10C445	290-0183-00			CAP, FXD, ELCTLT: 1UF, 10%, 35V	05397	T3228105K035AS
A10C447	281-0765-00			CAP, FXD, CER DI: 100PF, 5%, 100V	04222	MA101A101JAA
A10C451	281-0775-01			CAP, FXD, CER DI: 0.1UF, 20%, 50V	04222	SA105E104MAA
A10C452	281-0861-00			CAP, FXD, CER DI: 270PF, 5%, 50V	04222	SA101A271JAA
A10C453	281-0864-00			CAP, FXD, CER DI: 430PF, 5%, 100V	54583	MA12C0G2A431J
A10C454	290-0183-00			CAP, FXD, ELCTLT: 1UF, 10%, 35V	05397	T3228105K035AS
A10C455	281-0820-00	B010100	B020178	CAP, FXD, CER DI: 680 PF, 10%, 50V	04222	SA101C681KAA
A10C455	281-0861-00	B020179		CAP, FXD, CER DI: 270PF, 5%, 50V	04222	SA101A271JAA
A10C462	281-0864-00			CAP, FXD, CER DI: 430PF, 5%, 100V	54583	MA12C0G2A431J
A10C463	281-0813-00			CAP, FXD, CER DI: 0.047UF, 20%, 50V	05397	C412C473M5V2CA
A10C474	281-0776-00			CAP, FXD, CER DI: 120PF, 5%, 100V	20932	401E0100AD121J

Component No.	Tektronix Part No.	Serial/Assembly No.		Name & Description	Mfr. Code	Mfr. Part No.
		Effective	Dscont			
A10C475	290-0183-00			CAP, FXD, ELCTLT: 1UF, 10%, 35V	05397	T3228105K035AS
A10C476	281-0819-00			CAP, FXD, CER DI: 33 PF, 5%, 50V	04222	GC105A330J
A10C477	281-0872-00			CAP, FXD, CER DI: 91PF, 5%, 100V	04222	MC101A910J
A10C478	281-0864-00			CAP, FXD, CER DI: 430PF, 5%, 100V	54583	MA12C0G2A431J
A10C481	281-0909-00			CAP, FXD, CER DI: 0.022UF, 20%, 50V	54583	MA12X7R1H223M-T
A10C482	281-0909-00			CAP, FXD, CER DI: 0.022UF, 20%, 50V	54583	MA12X7R1H223M-T
A10C483	281-0820-00			CAP, FXD, CER DI: 680 PF, 10%, 50V	04222	SA101C681KAA
A10C484	281-0861-00			CAP, FXD, CER DI: 270PF, 5%, 50V	04222	SA101A271JAA
A10C485	281-0765-00	B010100	B010169	CAP, FXD, CER DI: 100PF, 5%, 100V	04222	MA101A101JAA
A10C485	281-0861-00	B010170		CAP, FXD, CER DI: 270PF, 5%, 50V	04222	SA101A271JAA
A10C486	281-0765-00	B010100	B010169	CAP, FXD, CER DI: 100PF, 5%, 100V	04222	MA101A101JAA
A10C487	281-0765-00			CAP, FXD, CER DI: 100PF, 5%, 100V	04222	MA101A101JAA
A10C488	281-0765-00	B010100	B010169	CAP, FXD, CER DI: 100PF, 5%, 100V	04222	MA101A101JAA
A10C489	281-0765-00			CAP, FXD, CER DI: 100PF, 5%, 100V	04222	MA101A101JAA
A10C490	281-0864-00	B010600		CAP, FXD, CER DI: 430PF, 5%, 100V	54583	MA12C0G2A431J
A10C491	281-0819-00			CAP, FXD, CER DI: 33 PF, 5%, 50V	04222	GC105A330J
A10C492	281-0819-00			CAP, FXD, CER DI: 33 PF, 5%, 50V	04222	GC105A330J
A10C493	281-0819-00			CAP, FXD, CER DI: 33 PF, 5%, 50V	04222	GC105A330J
A10C494	281-0819-00			CAP, FXD, CER DI: 33 PF, 5%, 50V	04222	GC105A330J
A10C496	281-0864-00	B010600		CAP, FXD, CER DI: 430PF, 5%, 100V	54583	MA12C0G2A431J
A10C501	281-0909-00			CAP, FXD, CER DI: 0.022UF, 20%, 50V	54583	MA12X7R1H223M-T
A10C502	281-0909-00			CAP, FXD, CER DI: 0.022UF, 20%, 50V	54583	MA12X7R1H223M-T
A10C503	281-0909-00			CAP, FXD, CER DI: 0.022UF, 20%, 50V	54583	MA12X7R1H223M-T
A10C505	281-0909-00			CAP, FXD, CER DI: 0.022UF, 20%, 50V	54583	MA12X7R1H223M-T
A10C600	281-0861-00			CAP, FXD, CER DI: 270PF, 5%, 50V	04222	SA101A271JAA
A10C601	281-0861-00			CAP, FXD, CER DI: 270PF, 5%, 50V	04222	SA101A271JAA
A10C602	281-0819-00			CAP, FXD, CER DI: 33 PF, 5%, 50V	04222	GC105A330J
A10C603	281-0819-00			CAP, FXD, CER DI: 33 PF, 5%, 50V	04222	GC105A330J
A10C604	281-0909-00			CAP, FXD, CER DI: 0.022UF, 20%, 50V	54583	MA12X7R1H223M-T
A10C605	281-0909-00			CAP, FXD, CER DI: 0.022UF, 20%, 50V	54583	MA12X7R1H223M-T
A10C606	281-0909-00			CAP, FXD, CER DI: 0.022UF, 20%, 50V	54583	MA12X7R1H223M-T
A10C607	281-0765-00			CAP, FXD, CER DI: 100PF, 5%, 100V	04222	MA101A101JAA
A10C608	281-0765-00			CAP, FXD, CER DI: 100PF, 5%, 100V	04222	MA101A101JAA
A10C609	281-0909-00			CAP, FXD, CER DI: 0.022UF, 20%, 50V	54583	MA12X7R1H223M-T
A10C610	281-0909-00			CAP, FXD, CER DI: 0.022UF, 20%, 50V	54583	MA12X7R1H223M-T
A10C611	281-0810-00			CAP, FXD, CER DI: 5.6PF, +/-0.5PF, 100V	04222	MA101A5R6DAA
A10C612	281-0810-00			CAP, FXD, CER DI: 5.6PF, +/-0.5PF, 100V	04222	MA101A5R6DAA
A10C613	281-0909-00			CAP, FXD, CER DI: 0.022UF, 20%, 50V	54583	MA12X7R1H223M-T
A10C614	281-0776-00			CAP, FXD, CER DI: 120PF, 5%, 100V	20932	401E0100A0121J
A10C666	281-0819-00	B020471		CAP, FXD, CER DI: 33 PF, 5%, 50V	04222	GC105A330J
A10C701	281-0909-00			CAP, FXD, CER DI: 0.022UF, 20%, 50V	54583	MA12X7R1H223M-T
A10C702	281-0909-00			CAP, FXD, CER DI: 0.022UF, 20%, 50V	54583	MA12X7R1H223M-T
A10C703	281-0909-00			CAP, FXD, CER DI: 0.022UF, 20%, 50V	54583	MA12X7R1H223M-T
A10C704	281-0909-00			CAP, FXD, CER DI: 0.022UF, 20%, 50V	54583	MA12X7R1H223M-T
A10C705	283-0057-00			CAP, FXD, CER DI: 0.1UF, +80-20%, 200V	04222	SR306E104ZAA
A10C706	281-0893-00			CAP, FXD, CER DI: 4.7PF, +/-0.5PF, 100V	04222	MA101A4R7DAA
A10C707	281-0798-00			CAP, FXD, CER DI: 51PF, 1%, 100V	04222	MA101A510GAA
A10C708	281-0909-00			CAP, FXD, CER DI: 0.022UF, 20%, 50V	54583	MA12X7R1H223M-T
A10C711	283-0201-01			CAP, FXD, CER DI: 27PF, 10%, 50V	51642	ADVISE
A10C712	283-0201-01			CAP, FXD, CER DI: 27PF, 10%, 50V	51642	ADVISE
A10C801	283-0057-00			CAP, FXD, CER DI: 0.1UF, +80-20%, 200V	04222	SR306E104ZAA
A10C802	283-0057-00			CAP, FXD, CER DI: 0.1UF, +80-20%, 200V	04222	SR306E104ZAA
A10C803	281-0909-00			CAP, FXD, CER DI: 0.022UF, 20%, 50V	54583	MA12X7R1H223M-T
A10C804	283-0057-00			CAP, FXD, CER DI: 0.1UF, +80-20%, 200V	04222	SR306E104ZAA
A10C805	281-0909-00			CAP, FXD, CER DI: 0.022UF, 20%, 50V	54583	MA12X7R1H223M-T
A10C806	281-0909-00			CAP, FXD, CER DI: 0.022UF, 20%, 50V	54583	MA12X7R1H223M-T
A10C807	281-0214-00			CAP, VAR, CER DI: 0.6-3PF, 400V	52763	313613-140
A10C808	281-0765-00			CAP, FXD, CER DI: 100PF, 5%, 100V	04222	MA101A101JAA

Replaceable Electrical Parts - 2247A Service

Component No.	Tektronix Part No.	Serial/Assembly No. Effective	Dscont	Name & Description	Mfr. Code	Mfr. Part No.
A10C809	283-0057-00			CAP,FXD,CER DI:0.1UF,+80-20%,200V	04222	SR306E104ZAA
A10C811	281-0909-00			CAP,FXD,CER DI:0.022UF,20%,50V	54583	MA12X7R1H223M-T
A10C814	281-0214-00			CAP,VAR,CER DI:0.6-3PF,400V	52763	313613-140
A10C815	281-0909-00			CAP,FXD,CER DI:0.022UF,20%,50V	54583	MA12X7R1H223M-T
A10C816	281-0909-00			CAP,FXD,CER DI:0.022UF,20%,50V	54583	MA12X7R1H223M-T
A10C817	290-1198-00			CAP,FXD,ELCTLT:100UF,20%,10VAC	80009	290-1198-00
A10C818	283-0057-00			CAP,FXD,CER DI:0.1UF,+80-20%,200V	04222	SR306E104ZAA
A10C819	281-0765-00			CAP,FXD,CER DI:100PF,5%,100V	04222	MA101A101JAA
A10C820	281-0909-00			CAP,FXD,CER DI:0.022UF,20%,50V	54583	MA12X7R1H223M-T
A10C821	281-0909-00			CAP,FXD,CER DI:0.022UF,20%,50V	54583	MA12X7R1H223M-T
A10C822	281-0909-00			CAP,FXD,CER DI:0.022UF,20%,50V	54583	MA12X7R1H223M-T
A10C860	281-0872-00	B010100	B010599	CAP,FXD,CER DI:91PF,5%,100V	04222	MC101A910J
A10C860	281-0765-00	B010600		CAP,FXD,CER DI:100PF,5%,100V	04222	MA101A101JAA
A10C870	281-0798-00	B010100	B010599	CAP,FXD,CER DI:51PF,1%,100V	04222	MA101A510GAA
A10C870	281-0816-00	B010600		CAP,FXD,CER DI:82 PF,5%,100V	04222	MA106A820JAA
A10C880	281-0909-00			CAP,FXD,CER DI:0.022UF,20%,50V	54583	MA12X7R1H223M-T
A10C901	281-0909-00			CAP,FXD,CER DI:0.022UF,20%,50V	54583	MA12X7R1H223M-T
A10C902	281-0909-00			CAP,FXD,CER DI:0.022UF,20%,50V	54583	MA12X7R1H223M-T
A10C903	290-0974-01			CAP,FXD,ELCTLT:10UF,20%,50V	55680	UVX1H100MAA1TA
A10C904	290-0974-01			CAP,FXD,ELCTLT:10UF,20%,50V	55680	UVX1H100MAA1TA
A10C910	281-0909-00			CAP,FXD,CER DI:0.022UF,20%,50V	54583	MA12X7R1H223M-T
A10C935	285-1339-00			CAP,FXD,MTLZD:0.022UF,10%,63V	55112	185/O.022/K63AAA
A10C1001	290-0974-01			CAP,FXD,ELCTLT:10UF,20%,50V	55680	UVX1H100MAA1TA
A10C1002	290-0974-01	B010100	B010686	CAP,FXD,ELCTLT:10UF,20%,50V	55680	UVX1H100MAA1TA
A10C1002	290-0974-00	B010687		CAP,FXD,ELCTLT:10UF,20%,50VDC	55680	ULB1H100MAA
A10C1003	290-0974-01	B010100	B010686	CAP,FXD,ELCTLT:10UF,20%,50V	55680	UVX1H100MAA1TA
A10C1003	290-0974-00	B010687		CAP,FXD,ELCTLT:10UF,20%,50VDC	55680	ULB1H100MAA
A10C1004	281-0909-00			CAP,FXD,CER DI:0.022UF,20%,50V	54583	MA12X7R1H223M-T
A10C1005	281-0909-00			CAP,FXD,CER DI:0.022UF,20%,50V	54583	MA12X7R1H223M-T
A10C1006	281-0909-00			CAP,FXD,CER DI:0.022UF,20%,50V	54583	MA12X7R1H223M-T
A10C1101	281-0909-00	B010100	B020545	CAP,FXD,CER DI:0.022UF,20%,50V	54583	MA12X7R1H223M-T
A10C1101	290-0183-00	B020546		CAP,FXD,ELCTLT:1UF,10%,35V	05397	T3228105K035AS
A10C1102	281-0909-00	B010100	B020545	CAP,FXD,CER DI:0.022UF,20%,50V	54583	MA12X7R1H223M-T
A10C1102	290-0183-00	B020456		CAP,FXD,ELCTLT:1UF,10%,35V	05397	T3228105K035AS
A10C1103	290-0183-00			CAP,FXD,ELCTLT:1UF,10%,35V	05397	T3228105K035AS
A10C1104	281-0909-00			CAP,FXD,CER DI:0.022UF,20%,50V	54583	MA12X7R1H223M-T
A10C1105	290-0974-01			CAP,FXD,ELCTLT:10UF,20%,50V	55680	UVX1H100MAA1TA
A10C1106	281-0820-00			CAP,FXD,CER DI:680 PF,10%,50V	04222	SA101C681KAA
A10C1107	281-0765-00			CAP,FXD,CER DI:100PF,5%,100V	04222	MA101A101JAA
A10C1108	290-0183-00	B020546		CAP,FXD,ELCTLT:1UF,10%,35V	05397	T3228105K035AS
A10C1110	281-0799-00			CAP,FXD,CER DI:62PF,2%,100V	04222	MA101A620GAA
A10C1111	281-0799-00			CAP,FXD,CER DI:62PF,2%,100V	04222	MA101A620GAA
A10C1114	290-0974-01			CAP,FXD,ELCTLT:10UF,20%,50V	55680	UVX1H100MAA1TA
A10C1130	281-0909-00			CAP,FXD,CER DI:0.022UF,20%,50V	54583	MA12X7R1H223M-T
A10C1143	281-0770-00	B020546		CAP,FXD,CER DI:1000PF,20%,100V	04222	MA101C102MAA
A10C1154	281-0909-00			CAP,FXD,CER DI:0.022UF,20%,50V	54583	MA12X7R1H223M-T
A10C1155	281-0909-00			CAP,FXD,CER DI:0.022UF,20%,50V	54583	MA12X7R1H223M-T
A10C1158	281-0909-00			CAP,FXD,CER DI:0.022UF,20%,50V	54583	MA12X7R1H223M-T
A10C1159	281-0909-00			CAP,FXD,CER DI:0.022UF,20%,50V	54583	MA12X7R1H223M-T
A10C1160	281-0909-00			CAP,FXD,CER DI:0.022UF,20%,50V	54583	MA12X7R1H223M-T
A10C2701	281-0909-00			CAP,FXD,CER DI:0.022UF,20%,50V	54583	MA12X7R1H223M-T
A10C2702	281-0909-00			CAP,FXD,CER DI:0.022UF,20%,50V	54583	MA12X7R1H223M-T
A10C2703	281-0909-00			CAP,FXD,CER DI:0.022UF,20%,50V	54583	MA12X7R1H223M-T
A10C2704	283-0348-00			CAP,FXD,CER DI:0.5PF,+/-0.1PF,100V	51642	W150100NP0508B
A10C2705	281-0771-00			CAP,FXD,CER DI:2200PF,20%,200V	04222	SA106E222MAA
A10C2706	281-0893-00			CAP,FXD,CER DI:4.7PF,+/-0.5PF,100V	04222	MA101A4R7DAA
A10C2707	281-0893-00			CAP,FXD,CER DI:4.7PF,+/-0.5PF,100V	04222	MA101A4R7DAA
A10C2708	283-0057-00			CAP,FXD,CER DI:0.1UF,+80-20%,200V	04222	SR306E104ZAA

Component No.	Tektronix Part No.	Serial/Assembly No. Effective Dscont	Name & Description	Mfr. Code	Mfr. Part No.
A10C2709	283-0057-00		CAP,FXD,CER DI:0.1UF,+80-20%,200V	04222	SR306E104ZAA
A10C2710	283-0057-00		CAP,FXD,CER DI:0.1UF,+80-20%,200V	04222	SR306E104ZAA
A10C2711	285-1184-01		CAP,FXD,MTLZD:0.01UF,20%,4KV	56289	430P103X040
A10C2712	285-1040-00		CAP,FXD,PLASTIC:1200PF,10%,4000V	04099	TEK-17A
A10C2713	281-0771-00		CAP,FXD,CER DI:2200PF,20%,200V	04222	SA106E222MAA
A10C2715	281-0909-00		CAP,FXD,CER DI:0.022UF,20%,50V	54583	MA12X7R1H223M-T
A10C2716	281-0771-00		CAP,FXD,CER DI:2200PF,20%,200V	04222	SA106E222MAA
A10C2717	283-0057-00		CAP,FXD,CER DI:0.1UF,+80-20%,200V	04222	SR306E104ZAA
A10C2719	285-1184-01		CAP,FXD,MTLZD:0.01UF,20%,4KV	56289	430P103X040
A10C2720	285-1040-00		CAP,FXD,PLASTIC:1200PF,10%,4000V	04099	TEK-17A
A10C2721	281-0771-00		CAP,FXD,CER DI:2200PF,20%,200V	04222	SA106E222MAA
A10C2723	281-0909-00		CAP,FXD,CER DI:0.022UF,20%,50V	54583	MA12X7R1H223M-T
A10C2724	285-1184-01		CAP,FXD,MTLZD:0.01UF,20%,4KV	56289	430P103X040
A10C2759	281-0759-00		CAP,FXD,CER DI:22PF,10%,100V	04222	MA101A220KAA
A10C2783	283-0057-00		CAP,FXD,CER DI:0.1UF,+80-20%,200V	04222	SR306E104ZAA
A10C2784	281-0909-00		CAP,FXD,CER DI:0.022UF,20%,50V	54583	MA12X7R1H223M-T
A10C2785	283-0057-00		CAP,FXD,CER DI:0.1UF,+80-20%,200V	04222	SR306E104ZAA
A10CR131	152-0246-00		SEMICON DVC,DI:SW,SI,40V,200MA,DO-7	14433	WG1537TK
A10CR151	152-0246-00		SEMICON DVC,DI:SW,SI,40V,200MA,DO-7	14433	WG1537TK
A10CR171	152-0141-02		SEMICON DVC,DI:SW,SI,30V,150MA,30V,DO-35	03508	DA2527 (1N4152)
A10CR201	152-0141-02		SEMICON DVC,DI:SW,SI,30V,150MA,30V,DO-35	03508	DA2527 (1N4152)
A10CR202	152-0141-02		SEMICON DVC,DI:SW,SI,30V,150MA,30V,DO-35	03508	DA2527 (1N4152)
A10CR260	152-0066-00		SEMICON DVC,DI:RECT,SI,400V,1A,DO-41	05828	GP10G-020
A10CR261	152-0066-00		SEMICON DVC,DI:RECT,SI,400V,1A,DO-41	05828	GP10G-020
A10CR301	152-0141-02		SEMICON DVC,DI:SW,SI,30V,150MA,30V,DO-35	03508	DA2527 (1N4152)
A10CR432	152-0246-00		SEMICON DVC,DI:SW,SI,40V,200MA,DO-7	14433	WG1537TK
A10CR462	152-0246-00		SEMICON DVC,DI:SW,SI,40V,200MA,DO-7	14433	WG1537TK
A10CR601	152-0141-02		SEMICON DVC,DI:SW,SI,30V,150MA,30V,DO-35 (OPTION 15 ONLY)	03508	DA2527 (1N4152)
A10CR602	152-0141-02		SEMICON DVC,DI:SW,SI,30V,150MA,30V,DO-35 (OPTION 15 ONLY)	03508	DA2527 (1N4152)
A10CR603	152-0141-02		SEMICON DVC,DI:SW,SI,30V,150MA,30V,DO-35	03508	DA2527 (1N4152)
A10CR612	152-0141-02		SEMICON DVC,DI:SW,SI,30V,150MA,30V,DO-35	03508	DA2527 (1N4152)
A10CR801	152-0141-02		SEMICON DVC,DI:SW,SI,30V,150MA,30V,DO-35	03508	DA2527 (1N4152)
A10CR802	152-0141-02		SEMICON DVC,DI:SW,SI,30V,150MA,30V,DO-35	03508	DA2527 (1N4152)
A10CR935	152-0141-02		SEMICON DVC,DI:SW,SI,30V,150MA,30V,DO-35	03508	DA2527 (1N4152)
A10CR936	152-0141-02		SEMICON DVC,DI:SW,SI,30V,150MA,30V,DO-35	03508	DA2527 (1N4152)
A10CR1001	152-0141-02		SEMICON DVC,DI:SW,SI,30V,150MA,30V,DO-35	03508	DA2527 (1N4152)
A10CR1002	152-0141-02		SEMICON DVC,DI:SW,SI,30V,150MA,30V,DO-35	03508	DA2527 (1N4152)
A10CR1003	152-0141-02		SEMICON DVC,DI:SW,SI,30V,150MA,30V,DO-35	03508	DA2527 (1N4152)
A10CR1004	152-0141-02		SEMICON DVC,DI:SW,SI,30V,150MA,30V,DO-35	03508	DA2527 (1N4152)
A10CR1005	152-0141-02		SEMICON DVC,DI:SW,SI,30V,150MA,30V,DO-35	03508	DA2527 (1N4152)
A10CR2701	152-0400-00		SEMICON DVC,DI:RECT,SI,400V,1A	14552	MB2501
A10CR2702	152-0400-00		SEMICON DVC,DI:RECT,SI,400V,1A	14552	MB2501
A10CR2703	152-0400-00		SEMICON DVC,DI:RECT,SI,400V,1A	14552	MB2501
A10CR2704	152-0400-00		SEMICON DVC,DI:RECT,SI,400V,1A	14552	MB2501
A10CR2705	152-0141-02		SEMICON DVC,DI:SW,SI,30V,150MA,30V,DO-35	03508	DA2527 (1N4152)
A10CR2707	152-0141-02		SEMICON DVC,DI:SW,SI,30V,150MA,30V,DO-35	03508	DA2527 (1N4152)
A10CR2713	152-0141-02		SEMICON DVC,DI:SW,SI,30V,150MA,30V,DO-35	03508	DA2527 (1N4152)
A10CR2714	152-0400-00		SEMICON DVC,DI:RECT,SI,400V,1A	14552	MB2501
A10CR2715	152-0400-00		SEMICON DVC,DI:RECT,SI,400V,1A	14552	MB2501
A10CR2716	152-0400-00		SEMICON DVC,DI:RECT,SI,400V,1A	14552	MB2501
A10CR2717	152-0400-00		SEMICON DVC,DI:RECT,SI,400V,1A	14552	MB2501
A10CR2718	152-0400-00		SEMICON DVC,DI:RECT,SI,400V,1A	14552	MB2501
A10DL22	119-2119-01		DELAY LINE, ELEC:	80009	119-2119-01
A10DS901	150-0146-00		LAMP, INCAND:14V,80MA,73E,WEDGE BASE	08806	73E
A10DS902	150-0146-00		LAMP, INCAND:14V,80MA,73E,WEDGE BASE	08806	73E
A10DS903	150-0146-00		LAMP, INCAND:14V,80MA,73E,WEDGE BASE	08806	73E

Replaceable Electrical Parts - 2247A Service

Component No.	Tektronix Part No.	Serial/Assembly No. Effective Dscnt	Name & Description	Mfr. Code	Mfr. Part No.
A10DS2701	150-0035-00		LAMP,GLOW:90V MAX,0.3MA,AID-T,WIRE LD	TK0213	JH005/3011JA
A10DS2702	150-0035-00		LAMP,GLOW:90V MAX,0.3MA,AID-T,WIRE LD	TK0213	JH005/3011JA
A10DS2703	150-0035-00		LAMP,GLOW:90V MAX,0.3MA,AID-T,WIRE LD	TK0213	JH005/3011JA
A10DS2704	150-0035-00		LAMP,GLOW:90V MAX,0.3MA,AID-T,WIRE LD	TK0213	JH005/3011JA
A10J11	131-3731-00		CONN,RCPT,ELEC:BNC,MALE	24931	28JR377-1
A10J12	131-3731-00		CONN,RCPT,ELEC:BNC,MALE	24931	28JR377-1
A10J13	131-3731-00		CONN,RCPT,ELEC:BNC,MALE	24931	28JR377-1
A10J14	131-3731-00		CONN,RCPT,ELEC:BNC,MALE	24931	28JR377-1
A10J15	131-3464-00		CONTACT,ELEC:BRASS	80009	131-3464-00
A10J601	131-3626-00		CONN,RCPT,ELEC:SIP STRIP RCPT 17 POSITION	00779	643649-1
A10J927	131-4546-00		CONN,RCPT,ELEC:HEADER,3 POS W/O.025 SQ	80009	131-4546-00
A10J1204	131-3638-00		CONN,RCPT,ELEC:HEADER,13 CIRCUIT,0.156 SPACING	80009	131-3638-00
A10K100	148-0174-00		RELAY,ARMATURE:1 FORM C,12VDC	TK1689	DS1EM-DC 12V
A10K101	148-0174-00		RELAY,ARMATURE:1 FORM C,12VDC	TK1689	DS1EM-DC 12V
A10K102	148-0173-01		RELAY,ARMATURE:12VDC	TK1689	RK1EDC12V
A10K103	148-0173-01		RELAY,ARMATURE:12VDC	TK1689	RK1EDC12V
A10K104	148-0174-00		RELAY,ARMATURE:1 FORM C,12VDC	TK1689	DS1EM-DC 12V
A10K105	148-0174-00		RELAY,ARMATURE:1 FORM C,12VDC	TK1689	DS1EM-DC 12V
A10K107	148-0174-00		RELAY,ARMATURE:1 FORM C,12VDC	TK1689	DS1EM-DC 12V
A10K108	148-0174-00		RELAY,ARMATURE:1 FORM C,12VDC	TK1689	DS1EM-DC 12V
A10K109	148-0173-01		RELAY,ARMATURE:12VDC	TK1689	RK1EDC12V
A10K110	148-0173-01		RELAY,ARMATURE:12VDC	TK1689	RK1EDC12V
A10K111	148-0174-00		RELAY,ARMATURE:1 FORM C,12VDC	TK1689	DS1EM-DC 12V
A10K112	148-0174-00		RELAY,ARMATURE:1 FORM C,12VDC	TK1689	DS1EM-DC 12V
A10L101	108-1319-00		INDUCTOR,FIXED:33UH,10%,1.8A	80009	108-1319-00
A10L102	108-1319-00		INDUCTOR,FIXED:33UH,10%,1.8A	80009	108-1319-00
A10L130	108-0682-00		COIL,RF:FIXED,61NH	80009	108-0682-00
A10L140	108-0682-00		COIL,RF:FIXED,61NH	80009	108-0682-00
A10L201	108-1319-00		INDUCTOR,FIXED:33UH,10%,1.8A	80009	108-1319-00
A10L216	108-1339-00		COIL,RF:FXD,330NH	80009	108-1339-00
A10L217	108-1339-00		COIL,RF:FXD,330NH	80009	108-1339-00
A10L426	108-1281-00		COIL,RF:FXD,2.2UH,10%	54583	SP0305-2R2K
A10L432	108-1341-00		COIL,RF:FXD,180NH,10%,0.1 OHM,1100MA MI AXIAL LEADS	80009	108-1341-00
A10L445	108-1339-00		COIL,RF:FXD,330NH	80009	108-1339-00
A10L462	108-1341-00		COIL,RF:FXD,180NH,10%,0.1 OHM,1100MA MI AXIAL LEADS	80009	108-1341-00
A10L475	108-1339-00		COIL,RF:FXD,330NH	80009	108-1339-00
A10L701	108-1339-00		COIL,RF:FXD,330NH	80009	108-1339-00
A10L702	108-1339-00		COIL,RF:FXD,330NH	80009	108-1339-00
A10L703	120-1688-00		TRANSFORMER,RF:TAPPED INDUCTOR	TK1441	86-504-1
A10L704	120-1688-00		TRANSFORMER,RF:TAPPED INDUCTOR	TK1441	86-504-1
A10Q131	151-1042-00		SEMICON DVC SE:FET,SI,TO-92 (LOCATIONS A & B)	80009	151-1042-00
A10Q151	151-1042-00		SEMICON DVC SE:FET,SI,TO-92 (LOCATIONS A & B)	80009	151-1042-00
A10Q171	151-0164-00		TRANSISTOR:PNP,SI,TO-92	04713	MPS2907A
A10Q250	151-0712-00		TRANSISTOR:PNP,SI,TO-92	04713	SPS8223
A10Q251	151-0712-00		TRANSISTOR:PNP,SI,TO-92	04713	SPS8223
A10Q252	151-0271-05		TRANSISTOR:PNP,SI,30MA,2GHZ,TO-92	80009	151-0271-05
A10Q253	151-0271-05		TRANSISTOR:PNP,SI,30MA,2GHZ,TO-92	80009	151-0271-05
A10Q284	151-0192-00		TRANSISTOR:NPN,SI,TO-92	04713	SPS8801
A10Q285	151-0192-00		TRANSISTOR:NPN,SI,TO-92	04713	SPS8801
A10Q301	151-0254-03		TRANSISTOR:DARLINGTON,NPN,SI	TK1016	MPSA14, TPE2
A10Q302	151-0188-00		TRANSISTOR:PNP,SI,TO-92	80009	151-0188-00
A10Q303	151-0188-00		TRANSISTOR:PNP,SI,TO-92	80009	151-0188-00
A10Q304	151-0830-00		TRANSISTOR:NPN,SI,AMPLIFIER,625,TO-92	80009	151-0830-00

Component No.	Tektronix Part No.	Serial/Assembly No. Effective Dscont	Name & Description	Mfr. Code	Mfr. Part No.
A10Q305	151-0830-00		TRANSISTOR:NPN,SI,AMPLIFIER,625,TO-92	80009	151-0830-00
A10Q306	151-0830-00		TRANSISTOR:NPN,SI,AMPLIFIER,625,TO-92	80009	151-0830-00
A10Q307	151-0829-00		TRANSISTOR:PNP,SI,TO-92	80009	151-0829-00
A10Q308	151-0830-00		TRANSISTOR:NPN,SI,AMPLIFIER,625,TO-92	80009	151-0830-00
A10Q309	151-0830-00		TRANSISTOR:NPN,SI,AMPLIFIER,625,TO-92	80009	151-0830-00
A10Q310	151-1042-00		SEMICOND DVC SE:FET,SI,TO-92 (LOCATIONS A & B)	80009	151-1042-00
A10Q311	151-0188-00		TRANSISTOR:PNP,SI,TO-92	80009	151-0188-00
A10Q312	151-0188-00		TRANSISTOR:PNP,SI,TO-92	80009	151-0188-00
A10Q313	151-0736-00		TRANSISTOR:NPN,SI,TO-92	80009	151-0736-00
A10Q315	151-0188-00		TRANSISTOR:PNP,SI,TO-92	80009	151-0188-00
A10Q316	151-0188-00		TRANSISTOR:PNP,SI,TO-92	80009	151-0188-00
A10Q317	151-0830-00		TRANSISTOR:NPN,SI,AMPLIFIER,625,TO-92	80009	151-0830-00
A10Q318	151-0830-00		TRANSISTOR:NPN,SI,AMPLIFIER,625,TO-92	80009	151-0830-00
A10Q320	151-0829-00		TRANSISTOR:PNP,SI,TO-92	80009	151-0829-00
A10Q321	151-0830-00		TRANSISTOR:NPN,SI,AMPLIFIER,625,TO-92	80009	151-0830-00
A10Q322	151-0830-00		TRANSISTOR:NPN,SI,AMPLIFIER,625,TO-92	80009	151-0830-00
A10Q323	151-1042-00		SEMICOND DVC SE:FET,SI,TO-92 (LOCATIONS A & B)	80009	151-1042-00
A10Q325	151-0188-00		TRANSISTOR:PNP,SI,TO-92	80009	151-0188-00
A10Q326	151-0736-00		TRANSISTOR:NPN,SI,TO-92	80009	151-0736-00
A10Q328	151-0829-00		TRANSISTOR:PNP,SI,TO-92	80009	151-0829-00
A10Q329	151-0829-00		TRANSISTOR:PNP,SI,TO-92	80009	151-0829-00
A10Q330	151-0829-00		TRANSISTOR:PNP,SI,TO-92	80009	151-0829-00
A10Q331	151-0829-00		TRANSISTOR:PNP,SI,TO-92	80009	151-0829-00
A10Q332	151-0736-00		TRANSISTOR:NPN,SI,TO-92	80009	151-0736-00
A10Q333	151-0736-00		TRANSISTOR:NPN,SI,TO-92	80009	151-0736-00
A10Q440	151-0188-00		TRANSISTOR:PNP,SI,TO-92	80009	151-0188-00
A10Q444	151-0190-00		TRANSISTOR:NPN,SI,TO-92	80009	151-0190-00
A10Q470	151-0188-00		TRANSISTOR:PNP,SI,TO-92	80009	151-0188-00
A10Q474	151-0190-00		TRANSISTOR:NPN,SI,TO-92	80009	151-0190-00
A10Q480	151-0188-00		TRANSISTOR:PNP,SI,TO-92	80009	151-0188-00
A10Q600	151-0188-00		TRANSISTOR:PNP,SI,TO-92	80009	151-0188-00
A10Q601	151-0424-00		TRANSISTOR:NPN,SI,TO-92	04713	SPS8246
A10Q602	151-0188-00		TRANSISTOR:PNP,SI,TO-92	80009	151-0188-00
A10Q603	151-0188-00		TRANSISTOR:PNP,SI,TO-92	80009	151-0188-00
A10Q604	151-0188-00		TRANSISTOR:PNP,SI,TO-92	80009	151-0188-00
A10Q605	151-0188-00		TRANSISTOR:PNP,SI,TO-92	80009	151-0188-00
A10Q606	151-0188-00		TRANSISTOR:PNP,SI,TO-92	80009	151-0188-00
A10Q607	151-0188-00		TRANSISTOR:PNP,SI,TO-92	80009	151-0188-00
A10Q608	151-0190-00		TRANSISTOR:NPN,SI,TO-92	80009	151-0190-00
A10Q701	151-0846-00		TRANSISTOR:NPN,SI,5W,TO-39	80009	151-0846-00
A10Q702	151-0846-00		TRANSISTOR:NPN,SI,5W,TO-39	80009	151-0846-00
A10Q703	151-0190-00		TRANSISTOR:NPN,SI,TO-92	80009	151-0190-00
A10Q704	151-0190-00		TRANSISTOR:NPN,SI,TO-92	80009	151-0190-00
A10Q801	151-0270-00		TRANSISTOR:PNP,SI,TO-39	04713	ST919
A10Q802	151-0274-00		TRANSISTOR:NPN,SI,TO-5	04713	SS7394
A10Q803	151-0190-00		TRANSISTOR:NPN,SI,TO-92	80009	151-0190-00
A10Q804	151-0190-00		TRANSISTOR:NPN,SI,TO-92	80009	151-0190-00
A10Q805	151-0270-00		TRANSISTOR:PNP,SI,TO-39	04713	ST919
A10Q806	151-0274-00		TRANSISTOR:NPN,SI,TO-5	04713	SS7394
A10Q807	151-0164-00		TRANSISTOR:PNP,SI,TO-92	04713	MPS2907A
A10Q809	151-0711-00		TRANSISTOR:NPN,SI,TO-92B	80009	151-0711-00
A10Q810	151-0711-00		TRANSISTOR:NPN,SI,TO-92B	80009	151-0711-00
A10Q811	151-0190-00		TRANSISTOR:NPN,SI,TO-92	80009	151-0190-00
A10Q812	151-0220-06		TRANSISTOR:PNP,SI	80009	151-0220-06
A10Q905	151-0622-00		TRANSISTOR:PNP,SI,40V,1A,TO-226AE/237	04713	SPS8956(MPSW51A)
A10Q907	151-0622-00		TRANSISTOR:PNP,SI,40V,1A,TO-226AE/237	04713	SPS8956(MPSW51A)

Replaceable Electrical Parts - 2247A Service

Component No.	Tektronix Part No.	Serial/Assembly No. Effective Dscnt	Name & Description	Mfr. Code	Mfr. Part No.
A10Q908	151-0622-00		TRANSISTOR: PNP, SI, 40V, 1A, TO-226AE/237	04713	SPS8956(MPSW51A)
A10Q1001	151-0424-00		TRANSISTOR: NPN, SI, TO-92	04713	SPS8246
A10Q1002	151-0424-00		TRANSISTOR: NPN, SI, TO-92	04713	SPS8246
A10Q1003	151-0424-00		TRANSISTOR: NPN, SI, TO-92	04713	SPS8246
A10Q1004	151-0424-00		TRANSISTOR: NPN, SI, TO-92	04713	SPS8246
A10Q1005	151-0216-04		TRANSISTOR: PNP, SI, TO-92	80009	151-0216-04
A10Q1101	151-0216-04		TRANSISTOR: PNP, SI, TO-92	80009	151-0216-04
A10Q1102	151-0192-00		TRANSISTOR: NPN, SI, TO-92	04713	SPS8801
A10Q1103	151-0216-04		TRANSISTOR: PNP, SI, TO-92	80009	151-0216-04
A10Q1104	151-0192-00		TRANSISTOR: NPN, SI, TO-92	04713	SPS8801
A10Q1105	151-0216-04		TRANSISTOR: PNP, SI, TO-92	80009	151-0216-04
A10Q1106	151-0192-00		TRANSISTOR: NPN, SI, TO-92	04713	SPS8801
A10Q2701	151-0164-00		TRANSISTOR: PNP, SI, TO-92	04713	MPS2907A
A10Q2702	151-0164-00		TRANSISTOR: PNP, SI, TO-92	04713	MPS2907A
A10Q2703	151-0736-00		TRANSISTOR: NPN, SI, TO-92	80009	151-0736-00
A10Q2704	151-0736-00		TRANSISTOR: NPN, SI, TO-92	80009	151-0736-00
A10Q2705	151-0192-00		TRANSISTOR: NPN, SI, TO-92	04713	SPS8801
A10Q2706	151-0190-00		TRANSISTOR: NPN, SI, TO-92	80009	151-0190-00
A10Q2707	151-0190-00		TRANSISTOR: NPN, SI, TO-92	80009	151-0190-00
A10Q2708	151-0188-00		TRANSISTOR: PNP, SI, TO-92	80009	151-0188-00
A10Q2709	151-0188-00		TRANSISTOR: PNP, SI, TO-92	80009	151-0188-00
A10Q2711	151-0199-00		TRANSISTOR: PNP, SI, TO-92	80009	151-0199-00
A10Q2712	151-0347-00		TRANSISTOR: NPN, SI, TO-92	04713	SPS7951
A10Q2713	151-0350-00		TRANSISTOR: PNP, SI, TO-92	04713	2N5401
A10Q2715	151-0190-00		TRANSISTOR: NPN, SI, TO-92	80009	151-0190-00
A10R101	313-1822-00		RES, FXD, FILM: 8.2K OHM, 5%, 0.2W	57668	TR20JE 08K2
A10R102	313-1822-00		RES, FXD, FILM: 8.2K OHM, 5%, 0.2W	57668	TR20JE 08K2
A10R103	313-1822-00		RES, FXD, FILM: 8.2K OHM, 5%, 0.2W	57668	TR20JE 08K2
A10R104	313-1822-00		RES, FXD, FILM: 8.2K OHM, 5%, 0.2W	57668	TR20JE 08K2
A10R105	313-1103-00		RES, FXD, FILM: 10K OHM, 5%, 0.2W	57668	TR20JE10K0
A10R106	313-1103-00		RES, FXD, FILM: 10K OHM, 5%, 0.2W	57668	TR20JE10K0
A10R107	313-1103-00		RES, FXD, FILM: 10K OHM, 5%, 0.2W	57668	TR20JE10K0
A10R108	313-1103-00		RES, FXD, FILM: 10K OHM, 5%, 0.2W	57668	TR20JE10K0
A10R111	315-0620-00		RES, FXD, FILM: 62 OHM, 5%, 0.25W	19701	5043CX63R00J
A10R113	313-1200-00		RES, FXD, FILM: 20 OHM, 5%, 0.2W	57668	TR20JE20E
A10R114	313-1100-00		RES, FXD, FILM: 10 OHM, 5%, 0.2W	57668	TR20JE10E0
A10R115	322-3085-00		RES, FXD, FILM: 75 OHM, 1%, 0.2W, TC=TO	57668	CRB20 FXE 75E0
A10R121	315-0620-00		RES, FXD, FILM: 62 OHM, 5%, 0.25W	19701	5043CX63R00J
A10R123	313-1200-00		RES, FXD, FILM: 20 OHM, 5%, 0.2W	57668	TR20JE20E
A10R124	313-1100-00		RES, FXD, FILM: 10 OHM, 5%, 0.2W	57668	TR20JE10E0
A10R125	322-3085-00		RES, FXD, FILM: 75 OHM, 1%, 0.2W, TC=TO	57668	CRB20 FXE 75E0
A10R131	315-0390-00		RES, FXD, FILM: 39 OHM, 5%, 0.25W	57668	NTR25J-E39E0
A10R132	322-3443-00		RES, FXD, FILM: 402K OHM, 1%, 0.2W, TC=TO	91637	CCF50G40202F
A10R133	322-3443-00		RES, FXD, FILM: 402K OHM, 1%, 0.2W, TC=TO	91637	CCF50G40202F
A10R134	322-3414-00		RES, FXD, FILM: 200K OHM, 1%, 0.2W, TC=TO	91637	CCF50G20002F
A10R135	313-1100-00		RES, FXD, FILM: 10 OHM, 5%, 0.2W	57668	TR20JE10E0
A10R136	322-3284-00		RES, FXD, FILM: 8.87K OHM, 1%, 0.2W, TC=TO	57668	CRB20 FXE 8K87
A10R137	322-3217-00		RES, FXD, FILM: 1.78K OHM, 1%, 0.2W, TC=TO	57668	CRB20 FXE 1K78
A10R138	322-3210-00		RES, FXD, FILM: 1.5K OHM, 1%, 0.2W, TC=TO	57668	CRB20 FXE 1K50
A10R139	322-3085-00		RES, FXD, FILM: 75 OHM, 1%, 0.2W, TC=TO	57668	CRB20 FXE 75E0
A10R140	322-3085-00		RES, FXD, FILM: 75 OHM, 1%, 0.2W, TC=TO	57668	CRB20 FXE 75E0
A10R141	311-2224-00		RES, VAR, NONNW: TRMR, 20 OHM, 20%, 0.5W LINEARTAPE & REEL	TK1450	GF06UT
A10R142	322-3056-00		RES, FXD, FILM: 37.4 OHM, 1%, 0.2W, TC=TO	80009	322-3056-00
A10R151	315-0390-00		RES, FXD, FILM: 39 OHM, 5%, 0.25W	57668	NTR25J-E39E0
A10R152	322-3443-00		RES, FXD, FILM: 402K OHM, 1%, 0.2W, TC=TO	91637	CCF50G40202F
A10R153	322-3443-00		RES, FXD, FILM: 402K OHM, 1%, 0.2W, TC=TO	91637	CCF50G40202F
A10R154	322-3414-00		RES, FXD, FILM: 200K OHM, 1%, 0.2W, TC=TO	91637	CCF50G20002F

Component No.	Tektronix Part No.	Serial/Assembly No. Effective	Dscont	Name & Description	Mfr. Code	Mfr. Part No.
A10R155	313-1100-00			RES,FXD,FILM:10 OHM,5%,0.2W	57668	TR20JE10E0
A10R156	322-3284-00			RES,FXD,FILM:8.87K OHM,1%,0.2W,TC=TO	57668	CRB20 FXE 8K87
A10R157	322-3217-00			RES,FXD,FILM:1.78K OHM,1%,0.2W,TC=TO	57668	CRB20 FXE 1K78
A10R158	322-3210-00			RES,FXD,FILM:1.5K OHM,1%,0.2W,TC=TO	57668	CRB20 FXE 1K50
A10R159	322-3085-00			RES,FXD,FILM:75 OHM,1%,0.2W,TC=TO	57668	CRB20 FXE 75E0
A10R160	322-3085-00			RES,FXD,FILM:75 OHM,1%,0.2W,TC=TO	57668	CRB20 FXE 75E0
A10R161	311-2224-00			RES,VAR,NONWW:TRMR,20 OHM,20%,0.5W LINEAR TAPE & REEL	TK1450	GF06UT
A10R162	322-3056-00			RES,FXD,FILM:37.4 OHM,1%,0.2W,TC=TO	80009	322-3056-00
A10R171	313-1471-00			RES,FXD,FILM:470 OHM,5%,0.2W	57668	TR20JE 470E
A10R175	313-1204-00			RES,FXD,FILM:200K,5%,0.2W	57668	TR20JE 200K
A10R176	313-1103-00			RES,FXD,FILM:10K OHM,5%,0.2W	57668	TR20JE10K0
A10R177	313-1472-00			RES,FXD,FILM:4.7K OHM,5%,0.2W	57668	TR20JE 04K7
A10R178	313-1472-00			RES,FXD,FILM:4.7K OHM,5%,0.2W	57668	TR20JE 04K7
A10R179	313-1103-00			RES,FXD,FILM:10K OHM,5%,0.2W	57668	TR20JE10K0
A10R180	313-1101-00			RES,FXD,FILM:100 OHM,5%,0.2W	57668	TR20JE100E
A10R181	313-1101-00			RES,FXD,FILM:100 OHM,5%,0.2W	57668	TR20JE100E
A10R182	308-0058-00			RES,FXD,WW:1.5 OHM,10%,1W	75042	BW-20-1R500K
A10R201	322-3193-00			RES,FXD,FILM:1K OHM,1%,0.2W,TC=TO	57668	CRB20 FXE 1K00
A10R202	322-3193-00			RES,FXD,FILM:1K OHM,1%,0.2W,TC=TO	57668	CRB20 FXE 1K00
A10R203	322-3193-00			RES,FXD,FILM:1K OHM,1%,0.2W,TC=TO	57668	CRB20 FXE 1K00
A10R204	322-3193-00			RES,FXD,FILM:1K OHM,1%,0.2W,TC=TO	57668	CRB20 FXE 1K00
A10R205	322-3150-00			RES,FXD,FILM:357 OHM,1%,0.2W,TC=TO	57668	CRB20 FXE 357E
A10R206	322-3236-00			RES,FXD,FILM:2.8K OHM,1%,0.2W,TC=TO	57668	CRB20 FXE 2K80
A10R207	322-3150-00			RES,FXD,FILM:357 OHM,1%,0.2W,TC=TO	57668	CRB20 FXE 357E
A10R208	313-1100-00			RES,FXD,FILM:10 OHM,5%,0.2W	57668	TR20JE10E0
A10R209	313-1511-00			RES,FXD,FILM:510 OHM,5%,0.2W	57668	TR20JT68 510E
A10R210	313-1331-00			RES,FXD,FILM:330 OHM,5%,0.2W	57668	TR20JE 330E
A10R211	311-2329-00	B010100	B010620	RES,VAR,NONWW:TRIMMER,5K OHM,10%	32997	3386R-EA5-502
A10R211	311-2454-00	B010621		RES,VAR,NONWW:TRMR,5K OHM,20%,0.5W,LOG	80009	311-2454-00
A10R212	313-1511-00			RES,FXD,FILM:510 OHM,5%,0.2W	57668	TR20JT68 510E
A10R213	313-1243-00			RES,FXD,FILM:24K OHM,5%,0.2W	80009	313-1243-00
A10R214	322-3285-00			RES,FXD,FILM:9.09K OHM,1%,0.2W,TC=TO	57668	CRB20 FXE 9K09
A10R215	313-1821-00			RES,FXD,FILM:820 OHM,5%,0.2W	57668	TR20JE 820E
A10R218	322-3237-00			RES,FXD,FILM:2.87K OHM,1%,0.2W,TC=TO	80009	322-3237-00
A10R219	313-1104-00			RES,FXD,FILM:100K OHM,5%,0.2W	57668	TR20JE100K
A10R220	313-1331-00			RES,FXD,FILM:330 OHM,5%,0.2W	57668	TR20JE 330E
A10R221	311-2329-00	B010100	B010620	RES,VAR,NONWW:TRIMMER,5K OHM,10%	32997	3386R-EA5-502
A10R221	311-2454-00	B010621		RES,VAR,NONWW:TRMR,5K OHM,20%,0.5W,LOG	80009	311-2454-00
A10R222	313-1511-00			RES,FXD,FILM:510 OHM,5%,0.2W	57668	TR20JT68 510E
A10R223	313-1243-00			RES,FXD,FILM:24K OHM,5%,0.2W	80009	313-1243-00
A10R224	322-3285-00			RES,FXD,FILM:9.09K OHM,1%,0.2W,TC=TO	57668	CRB20 FXE 9K09
A10R225	313-1472-00			RES,FXD,FILM:4.7K OHM,5%,0.2W	57668	TR20JE 04K7
A10R226	313-1027-00			RES,FXD,FILM:2.7 OHM,5%,0.2W	57668	TR20JE 02E7
A10R227	313-1472-00			RES,FXD,FILM:4.7K OHM,5%,0.2W	57668	TR20JE 04K7
A10R228	322-3237-00			RES,FXD,FILM:2.87K OHM,1%,0.2W,TC=TO	80009	322-3237-00
A10R229	313-1104-00			RES,FXD,FILM:100K OHM,5%,0.2W	57668	TR20JE100K
A10R230	313-1331-00			RES,FXD,FILM:330 OHM,5%,0.2W	57668	TR20JE 330E
A10R231	311-2329-00	B010100	B010620	RES,VAR,NONWW:TRIMMER,5K OHM,10%	32997	3386R-EA5-502
A10R231	311-2454-00	B010621		RES,VAR,NONWW:TRMR,5K OHM,20%,0.5W,LOG	80009	311-2454-00
A10R232	313-1511-00			RES,FXD,FILM:510 OHM,5%,0.2W	57668	TR20JT68 510E
A10R233	313-1243-00			RES,FXD,FILM:24K OHM,5%,0.2W	80009	313-1243-00
A10R234	322-3285-00			RES,FXD,FILM:9.09K OHM,1%,0.2W,TC=TO	57668	CRB20 FXE 9K09
A10R235	322-3237-00			RES,FXD,FILM:2.87K OHM,1%,0.2W,TC=TO	80009	322-3237-00
A10R238	313-1100-00			RES,FXD,FILM:10 OHM,5%,0.2W	57668	TR20JE10E0
A10R240	313-1331-00			RES,FXD,FILM:330 OHM,5%,0.2W	57668	TR20JE 330E
A10R241	311-2329-00	B010100	B010620	RES,VAR,NONWW:TRIMMER,5K OHM,10%	32997	3386R-EA5-502
A10R241	311-2454-00	B010621		RES,VAR,NONWW:TRMR,5K OHM,20%,0.5W,LOG	80009	311-2454-00

Replaceable Electrical Parts - 2247A Service

Component No.	Tektronix Part No.	Serial/Assembly No. Effective Dscnt	Name & Description	Mfr. Code	Mfr. Part No.
A10R242	313-1511-00		RES,FXD,FILM:510 OHM,5%,0.2W	57668	TR20JT68 510E
A10R243	313-1243-00		RES,FXD,FILM:24K OHM,5%,0.2W	80009	313-1243-00
A10R244	322-3285-00		RES,FXD,FILM:9.09K OHM,1%,0.2W,TC=TO	57668	CRB20 FXE 9K09
A10R245	313-1027-00		RES,FXD,FILM:2.7 OHM,5%,0.2W	57668	TR20JE 02E7
A10R248	322-3237-00		RES,FXD,FILM:2.87K OHM,1%,0.2W,TC=TO	80009	322-3237-00
A10R250	307-0792-00		RES NTWK,FXD,FI:7.82 OHM,2%,0.15W EACH	11236	750-81-R82
A10R251	307-0792-00		RES NTWK,FXD,FI:7.82 OHM,2%,0.15W EACH	11236	750-81-R82
A10R254	322-3318-00		RES,FXD,FILM:20K OHM,1%,0.2W,TC=TO	57668	CRB20 FXE 20K0
A10R255	322-3318-00		RES,FXD,FILM:20K OHM,1%,0.2W,TC=TO	57668	CRB20 FXE 20K0
A10R256	313-1103-00		RES,FXD,FILM:10K OHM,5%,0.2W	57668	TR20JE10K0
A10R260	311-2234-00		RES,VAR,NONNW:TRMR,5K OHM,20%,0.5W LINEARTA PE & REEL	TK1450	GF06UT 5K
A10R261	313-1243-00		RES,FXD,FILM:24K OHM,5%,0.2W	80009	313-1243-00
A10R262	322-3083-00		RES,FXD,FILM:71.5 OHM,1%,0.2W,TC=TO	57668	CRB20 FXE 71E5
A10R263	322-3083-00		RES,FXD,FILM:71.5 OHM,1%,0.2W,TC=TO	57668	CRB20 FXE 71E5
A10R264	322-3083-00		RES,FXD,FILM:71.5 OHM,1%,0.2W,TC=TO	57668	CRB20 FXE 71E5
A10R265	322-3083-00		RES,FXD,FILM:71.5 OHM,1%,0.2W,TC=TO	57668	CRB20 FXE 71E5
A10R266	313-1302-00		RES,FXD,FILM:3K OHM,5%,0.2W	57668	TR20JE 03K0
A10R267	322-3164-00		RES,FXD,FILM:499 OHM,1%,0.2W,TC=TO	57668	CRB20 FXE 499E
A10R268	322-3158-00		RES,FXD,FILM:432 OHM,1%,0.2W,TC=TO	57668	CRB20 FXE 432
A10R269	322-3158-00		RES,FXD,FILM:432 OHM,1%,0.2W,TC=TO	57668	CRB20 FXE 432
A10R270	313-1751-00		RES,FXD,FILM:750 OHM,5%,0.2W	57668	TR20JE 750E
A10R271	313-1912-00		RES,FXD,FILM:9.1K OHM,5%,0.2W	57668	TR20 FXE 9.1K
A10R272	311-2232-00		RES,VAR,NONNW:TRMR,2K OHM,20%,0.5W LINEAR	TK1450	GF06UT 2K
A10R273	311-2230-00		RES,VAR,NONNW:TRMR,500 OHM,20%,0.50 LINEAR	TK1450	GF06UT 500
A10R274	313-1100-00		RES,FXD,FILM:10 OHM,5%,0.2W	57668	TR20JE10E0
A10R275	311-2227-00		RES,VAR,NONNW:TRMR,100 OHM,20%,0.5W LINEAR	TK1450	GF06UT 100
A10R276	322-3213-00		RES,FXD,FILM:1.62K OHM,1%,0.2W,TC=TO	57668	CRB20 FXE 1K62
A10R277	322-3213-00		RES,FXD,FILM:1.62K OHM,1%,0.2W,TC=TO	57668	CRB20 FXE 1K62
A10R278	322-3141-00		RES,FXD,FILM:287 OHM,1%,0.2W,TC=TO	57668	CRB20 FXE 287E
A10R279	322-3141-00		RES,FXD,FILM:287 OHM,1%,0.2W,TC=TO	57668	CRB20 FXE 287E
A10R280	322-3098-00		RES,FXD,FILM:102 OHM,1%,0.2W,TC=TO	57668	CRB20 FXE 102E
A10R281	322-3098-00		RES,FXD,FILM:102 OHM,1%,0.2W,TC=TO	57668	CRB20 FXE 102E
A10R282	313-1100-00		RES,FXD,FILM:10 OHM,5%,0.2W	57668	TR20JE10E0
A10R283	313-1100-00		RES,FXD,FILM:10 OHM,5%,0.2W	57668	TR20JE10E0
A10R284	313-1393-00		RES,FXD,FILM:39K OHM,5%,0.2W	57668	TR20JE 39K
A10R285	313-1393-00		RES,FXD,FILM:39K OHM,5%,0.2W	57668	TR20JE 39K
A10R286	322-3097-00		RES,FXD,FILM:100 OHM,1%,0.2W,TC=TO	57668	CRB20 FXE 100E
A10R287	322-3097-00		RES,FXD,FILM:100 OHM,1%,0.2W,TC=TO	57668	CRB20 FXE 100E
A10R288	322-3193-00		RES,FXD,FILM:1K OHM,1%,0.2W,TC=TO	57668	CRB20 FXE 1K00
A10R289	322-3193-00		RES,FXD,FILM:1K OHM,1%,0.2W,TC=TO	57668	CRB20 FXE 1K00
A10R290	322-3123-00		RES,FXD,FILM:187 OHM,1%,0.2W,TC=TO	57668	CRB20 FXE 187E
A10R291	322-3123-00		RES,FXD,FILM:187 OHM,1%,0.2W,TC=TO	57668	CRB20 FXE 187E
A10R292	313-1752-00		RES,FXD,FILM:7.5K OHM,5%,0.2W	57668	TR20JE 07K5
A10R293	313-1752-00		RES,FXD,FILM:7.5K OHM,5%,0.2W	57668	TR20JE 07K5
A10R294	313-1202-00		RES,FXD,FILM:2K OHM,5%,0.2W	57668	TR20JE02K0
A10R295	313-1302-00		RES,FXD,FILM:3K OHM,5%,0.2W	57668	TR20JE 03K0
A10R296	322-3117-00		RES,FXD,FILM:162 OHM,1%,0.2W,TC=TO	57668	CRB 20 FXE 162E
A10R297	313-1100-00		RES,FXD,FILM:10 OHM,5%,0.2W	57668	TR20JE10E0
A10R298	313-1027-00		RES,FXD,FILM:2.7 OHM,5%,0.2W	57668	TR20JE 02E7
A10R301	313-1102-00		RES,FXD,FILM:1K OHM,5%,0.2W	57668	TR20JE01K0
A10R302	313-1027-00		RES,FXD,FILM:2.7 OHM,5%,0.2W	57668	TR20JE 02E7
A10R303	313-1102-00		RES,FXD,FILM:1K OHM,5%,0.2W	57668	TR20JE01K0
A10R304	313-1470-00		RES,FXD,FILM:47 OHM,5%,0.2W	57668	TR20JE 47E
A10R305	313-1511-00		RES,FXD,FILM:510 OHM,5%,0.2W	57668	TR20JT68 510E
A10R306	313-1051-00		RES,FXD,FILM:5.1 OHM,5%,0.2W	57668	TR20JT68 05E1
A10R307	322-3328-02		RES,FXD,FILM:25.5K OHM,0.5%,0.2W,TC=T2	57668	CRB20 DYE 25K5
A10R308	322-3319-02		RES,FXD,FILM:20.5K OHM,0.5%,0.2W,TC=T2	57668	CRB20 DYE 20K5

Component No.	Tektronix Part No.	Serial/Assembly No. Effective Dscnt	Name & Description	Mfr. Code	Mfr. Part No.
A10R309	322-3289-00		RES,FXD,FILM:10K OHM,1%,0.2W,TC=TO	57668	CRB20 FXE 10K0
A10R310	313-1473-00		RES,FXD,FILM:47K OHM,5%,0.2W	57668	TR20JE 47K
A10R311	322-3269-02		RES,FXD,FILM:6.19K OHM,0.2W,5%	57668	CRB DYE 6K19
A10R312	313-1100-00		RES,FXD,FILM:10 OHM,5%,0.2W	57668	TR20JE10E0
A10R313	307-2132-00		RES NTWK,FXD,FI:REF VOLTAGE DIVIDER	80009	307-2132-00
A10R314	322-3333-02		RES,FXD,FILM:28.7K OHM,0.2W,5%	57668	CRB20 DYE 28K7
A10R315	313-1470-00		RES,FXD,FILM:47 OHM,5%,0.2W	57668	TR20JE 47E
A10R316	313-1270-00		RES,FXD,FILM:100 OHM 5%,0.2W	57668	TR20JT68 27E
A10R317	313-1101-00		RES,FXD,FILM:27 OHM,5%,0.2W	57668	TR20JE100E
A10R318	313-1681-00		RES,FXD,FILM:680 OHM,5%,0.2W	57668	TR20JE 680E
A10R319	313-1562-00		RES,FXD,FILM:5.6K OHM,5%,0.2W	57668	TR20JE 05K6
A10R320	313-1470-00		RES,FXD,FILM:47 OHM,5%,0.2W	57668	TR20JE 47E
A10R321	307-2133-00		RES NTWK,FXD,FI:RESISTOR NETWORK	80009	307-2133-00
A10R322	313-1512-00		RES,FXD,FILM:5.1K OHM,5%,0.2W	57668	TR20JE 5K1
A10R323	313-1512-00		RES,FXD,FILM:5.1K OHM,5%,0.2W	57668	TR20JE 5K1
A10R325	313-1132-00		RES,FXD,FILM:1.3K OHM,5%,0.2W	57668	TR20JE01K3
A10R326	313-1132-00		RES,FXD,FILM:1.3K OHM,5%,0.2W	57668	TR20JE01K3
A10R327	313-1470-00		RES,FXD,FILM:47 OHM,5%,0.2W	57668	TR20JE 47E
A10R328	313-1101-00		RES,FXD,FILM:100 OHM,5%,0.2W	57668	TR20JE100E
A10R329	313-1101-00		RES,FXD,FILM:100 OHM,5%,0.2W	57668	TR20JE100E
A10R330	313-1101-00		RES,FXD,FILM:100 OHM,5%,0.2W	57668	TR20JE100E
A10R331	313-1392-00		RES,FXD,FILM:3.9K OHM,5%,0.2W	57668	TR20JE 03K9
A10R332	313-1820-00		RES,FXD,FILM:82 OHM,5%,0.2W	57668	TR20JE 82E
A10R333	313-1120-00		RES,FXD,FILM:12 OHM,5%,0.2W	57668	TR20JE12E0
A10R334	313-1151-00		RES,FXD,FILM:150 OHM,5%,0.2W	57668	TR20JE150E
A10R335	313-1162-00		RES,FXD,FILM:1.6K OHM,5%,0.2W	57668	TR20JT681K6
A10R336	313-1162-00		RES,FXD,FILM:1.6K OHM,5%,0.2W	57668	TR20JT681K6
A10R337	313-1151-00		RES,FXD,FILM:150 OHM,5%,0.2W	57668	TR20JE150E
A10R338	313-1132-00		RES,FXD,FILM:1.3K OHM,5%,0.2W	57668	TR20JE01K3
A10R339	313-1100-00		RES,FXD,FILM:10 OHM,5%,0.2W	57668	TR20JE10E0
A10R340	313-1820-00		RES,FXD,FILM:82 OHM,5%,0.2W	57668	TR20JE 82E
A10R341	313-1162-00		RES,FXD,FILM:1.6K OHM,5%,0.2W	57668	TR20JT681K6
A10R342	313-1132-00		RES,FXD,FILM:1.3K OHM,5%,0.2W	57668	TR20JE01K3
A10R343	313-1162-00		RES,FXD,FILM:1.6K OHM,5%,0.2W	57668	TR20JT681K6
A10R344	313-1332-00		RES,FXD,FILM:3.3K OHM,5%,0.2W	57668	TR20JE 03K3
A10R345	313-1100-00		RES,FXD,FILM:10 OHM,5%,0.2W	57668	TR20JE10E0
A10R346	313-1101-00		RES,FXD,FILM:100 OHM,5%,0.2W	57668	TR20JE100E
A10R347	313-1202-00		RES,FXD,FILM:2K OHM,5%,0.2W	57668	TR20JE02K0
A10R348	322-3193-00		RES,FXD,FILM:1K OHM,1%,0.2W,TC=TO	57668	CRB20 FXE 1K00
A10R349	322-3193-00		RES,FXD,FILM:1K OHM,1%,0.2W,TC=TO	57668	CRB20 FXE 1K00
A10R350	307-0540-00		RES NTWK,FXD,FI:(5)1K OHM,10%,0.7W	11236	750-61-R1K0HM
A10R352	322-3193-00		RES,FXD,FILM:1K OHM,1%,0.2W,TC=TO	57668	CRB20 FXE 1K00
A10R353	313-1152-00		RES,FXD,FILM:1.5K OHM,5%,0.2W	57668	TR20JE01K5
A10R354	313-1101-00		RES,FXD,FILM:100 OHM,5%,0.2W	57668	TR20JE100E
A10R355	313-1681-00		RES,FXD,FILM:680 OHM,5%,0.2W	57668	TR20JE 680E
A10R356	313-1562-00		RES,FXD,FILM:5.6K OHM,5%,0.2W	57668	TR20JE 05K6
A10R357	307-0540-00		RES NTWK,FXD,FI:(5)1K OHM,10%,0.7W	11236	750-61-R1K0HM
A10R358	313-1561-00		RES,FXD,FILM:560 OHM,5%,0.2W	57668	TR20JE 560E
A10R359	313-1162-00		RES,FXD,FILM:1.6K OHM,5%,0.2W	57668	TR20JT681K6
A10R360	313-1162-00		RES,FXD,FILM:1.6K OHM,5%,0.2W	57668	TR20JT681K6
A10R361	313-1200-00		RES,FXD,FILM:20 OHM,5%,0.2W	57668	TR20JE20E
A10R362	313-1392-00		RES,FXD,FILM:3.9K OHM,5%,0.2W	57668	TR20JE 03K9
A10R363	313-1332-00		RES,FXD,FILM:3.3K OHM,5%,0.2W	57668	TR20JE 03K3
A10R364	313-1511-00		RES,FXD,FILM:510 OHM,5%,0.2W	57668	TR20JT68 510E
A10R365	313-1132-00		RES,FXD,FILM:1.3K OHM,5%,0.2W	57668	TR20JE01K3
A10R366	313-1102-00		RES,FXD,FILM:1K OHM,5%,0.2W	57668	TR20JE01K0
A10R367	313-1102-00		RES,FXD,FILM:1K OHM,5%,0.2W	57668	TR20JE01K0
A10R369	313-1331-00		RES,FXD,FILM:330 OHM,5%,0.2W	57668	TR20JE 330E

Replaceable Electrical Parts - 2247A Service

Component No.	Tektronix Part No.	Serial/Assembly No. Effective Dscnt	Name & Description	Mfr. Code	Mfr. Part No.
A10R370	313-1820-00		RES,FXD,FILM:82 OHM,5%,0.2W	57668	TR20JE 82E
A10R371	313-1120-00		RES,FXD,FILM:12 OHM,5%,0.2W	57668	TR20JE12E0
A10R372	313-1200-00		RES,FXD,FILM:20 OHM,5%,0.2W	57668	TR20JE20E
A10R373	313-1820-00		RES,FXD,FILM:82 OHM,5%,0.2W	57668	TR20JE 82E
A10R374	313-1100-00		RES,FXD,FILM:10 OHM,5%,0.2W	57668	TR20JE10E0
A10R375	313-1101-00		RES,FXD,FILM:100 OHM,5%,0.2W	57668	TR20JE100E
A10R376	313-1332-00		RES,FXD,FILM:3.3K OHM,5%,0.2W	57668	TR20JE 03K3
A10R377	322-3193-00		RES,FXD,FILM:1K OHM,1%,0.2W,TC=TO	57668	CRB20 FXE 1K00
A10R378	313-1820-00		RES,FXD,FILM:82 OHM,5%,0.2W	57668	TR20JE 82E
A10R379	322-3193-00		RES,FXD,FILM:1K OHM,1%,0.2W,TC=TO	57668	CRB20 FXE 1K00
A10R380	313-1820-00		RES,FXD,FILM:82 OHM,5%,0.2W	57668	TR20JE 82E
A10R381	313-1270-00		RES,FXD,FILM:27 OHM 5%,0.2W	57668	TR20JT68 27E
A10R382	322-3193-00		RES,FXD,FILM:1K OHM,1%,0.2W,TC=TO	57668	CRB20 FXE 1K00
A10R383	313-1151-00		RES,FXD,FILM:150 OHM,5%,0.2W	57668	TR20JE150E
A10R384	313-1512-00		RES,FXD,FILM:5.1K OHM,5%,0.2W	57668	TR20JE 5K1
A10R385	313-1162-00		RES,FXD,FILM:1.6K OHM,5%,0.2W	57668	TR20JT681K6
A10R386	313-1162-00		RES,FXD,FILM:1.6K OHM,5%,0.2W	57668	TR20JT681K6
A10R387	313-1820-00		RES,FXD,FILM:82 OHM,5%,0.2W	57668	TR20JE 82E
A10R388	313-1820-00		RES,FXD,FILM:82 OHM,5%,0.2W	57668	TR20JE 82E
A10R390	313-1100-00		RES,FXD,FILM:10 OHM,5%,0.2W	57668	TR20JE10E0
A10R392	313-1100-00		RES,FXD,FILM:10 OHM,5%,0.2W	57668	TR20JE10E0
A10R393	313-1471-00		RES,FXD,FILM:470 OHM,5%,0.2W	57668	TR20JE 470E
A10R394	313-1471-00		RES,FXD,FILM:470 OHM,5%,0.2W	57668	TR20JE 470E
A10R395	313-1102-00		RES,FXD,FILM:1K OHM,5%,0.2W	57668	TR20JE01K0
A10R396	313-1102-00		RES,FXD,FILM:1K OHM,5%,0.2W	57668	TR20JE01K0
A10R401	313-1101-00		RES,FXD,FILM:100 OHM,5%,0.2W	57668	TR20JE100E
A10R402	313-1101-00		RES,FXD,FILM:100 OHM,5%,0.2W	57668	TR20JE100E
A10R403	313-1511-00		RES,FXD,FILM:510 OHM,5%,0.2W	57668	TR20JT68 510E
A10R410	313-1331-00		RES,FXD,FILM:330 OHM,5%,0.2W	57668	TR20JE 330E
A10R411	313-1151-00		RES,FXD,FILM:150 OHM,5%,0.2W	57668	TR20JE150E
A10R412	313-1151-00		RES,FXD,FILM:150 OHM,5%,0.2W	57668	TR20JE150E
A10R413	313-1331-00		RES,FXD,FILM:330 OHM,5%,0.2W	57668	TR20JE 330E
A10R414	313-1331-00		RES,FXD,FILM:330 OHM,5%,0.2W	57668	TR20JE 330E
A10R415	313-1151-00		RES,FXD,FILM:150 OHM,5%,0.2W	57668	TR20JE150E
A10R416	313-1151-00		RES,FXD,FILM:150 OHM,5%,0.2W	57668	TR20JE150E
A10R417	313-1331-00		RES,FXD,FILM:330 OHM,5%,0.2W	57668	TR20JE 330E
A10R420	313-1271-00		RES,FXD,FILM:270 OHM,5%,0.2W	57668	TR20JE 270E
A10R421	322-3279-00		RES,FXD,FILM:7.87K OHM,1%,0.2W,TC=TO	57668	CRB20 FXE 7K87
A10R422	322-3279-00		RES,FXD,FILM:7.87K OHM,1%,0.2W,TC=TO	57668	CRB20 FXE 7K87
A10R423	322-3279-00		RES,FXD,FILM:7.87K OHM,1%,0.2W,TC=TO	57668	CRB20 FXE 7K87
A10R424	322-3279-00		RES,FXD,FILM:7.87K OHM,1%,0.2W,TC=TO	57668	CRB20 FXE 7K87
A10R425	313-1750-00		RES,FXD,FILM:75 OHM,5%,0.2W	57668	TR20JE 75E
A10R426	313-1101-00		RES,FXD,FILM:100 OHM,5%,0.2W	57668	TR20JE100E
A10R430	313-1271-00		RES,FXD,FILM:270 OHM,5%,0.2W	57668	TR20JE 270E
A10R431	313-1750-00		RES,FXD,FILM:75 OHM,5%,0.2W	57668	TR20JE 75E
A10R432	322-3074-00		RES,FXD,FILM:57.6 OHM,1%,0.2W,TC=TO	80009	322-3074-00
A10R440	313-1104-00		RES,FXD,FILM:100K OHM,5%,0.2W	57668	TR20JE100K
A10R441	313-1621-00		RES,FXD,FILM:620 OHM,5%,0.2W	57668	TR20JE 620E
A10R442	313-1562-00		RES,FXD,FILM:5.6K OHM,5%,0.2W	57668	TR20JE 05K6
A10R443	313-1562-00		RES,FXD,FILM:5.6K OHM,5%,0.2W	57668	TR20JE 05K6
A10R444	313-1561-00		RES,FXD,FILM:560 OHM,5%,0.2W	57668	TR20JE 560E
A10R445	322-3143-00		RES,FXD,FILM:301 OHM,1%,0.2W,TC=TO	57668	CRB20 FXE 301E
A10R446	313-1331-00		RES,FXD,FILM:330 OHM,5%,0.2W	57668	TR20JE 330E
A10R447	322-3285-00		RES,FXD,FILM:9.09K OHM,1%,0.2W,TC=TO	57668	CRB20 FXE 9K09
A10R448	322-3333-02		RES,FXD,FILM:28.7K OHM,0.2W,5%	57668	CRB20 DYE 28K7
A10R449	313-1392-00		RES,FXD,FILM:3.9K OHM,5%,0.2W	57668	TR20JE 03K9
A10R450	313-1271-00		RES,FXD,FILM:270 OHM,5%,0.2W	57668	TR20JE 270E
A10R451	322-3279-00		RES,FXD,FILM:7.87K OHM,1%,0.2W,TC=TO	57668	CRB20 FXE 7K87

Component No.	Tektronix Part No.	Serial/Assembly No. Effective	Dscont	Name & Description	Mfr. Code	Mfr. Part No.
A10R452	322-3279-00			RES,FXD,FILM:7.87K OHM,1%,0.2W,TC=TO	57668	CRB20 FXE 7K87
A10R453	322-3279-00			RES,FXD,FILM:7.87K OHM,1%,0.2W,TC=TO	57668	CRB20 FXE 7K87
A10R454	322-3279-00			RES,FXD,FILM:7.87K OHM,1%,0.2W,TC=TO	57668	CRB20 FXE 7K87
A10R455	311-2230-00			RES,VAR,NONW:TRMR,500 OHM,20%,0.50 LINEAR	TK1450	GF06UT 500
A10R456	313-1103-00			RES,FXD,FILM:10K OHM,5%,0.2W	57668	TR20JE10K0
A10R460	313-1271-00			RES,FXD,FILM:270 OHM,5%,0.2W	57668	TR20JE 270E
A10R461	313-1101-00			RES,FXD,FILM:100 OHM,5%,0.2W	57668	TR20JE100E
A10R462	322-3074-00			RES,FXD,FILM:57.6 OHM,1%,0.2W,TC=TO	80009	322-3074-00
A10R463	313-1120-00			RES,FXD,FILM:12 OHM,5%,0.2W	57668	TR20JE12E0
A10R470	313-1104-00			RES,FXD,FILM:100K OHM,5%,0.2W	57668	TR20JE100K
A10R471	313-1621-00			RES,FXD,FILM:620 OHM,5%,0.2W	57668	TR20JE 620E
A10R472	313-1562-00			RES,FXD,FILM:5.6K OHM,5%,0.2W	57668	TR20JE 05K6
A10R473	313-1562-00			RES,FXD,FILM:5.6K OHM,5%,0.2W	57668	TR20JE 05K6
A10R474	313-1561-00			RES,FXD,FILM:560 OHM,5%,0.2W	57668	TR20JE 560E
A10R475	322-3328-02			RES,FXD,FILM:25.5K OHM,0.5%,0.2W,TC=T2	57668	CRB20 DYE 25K5
A10R476	313-1392-00			RES,FXD,FILM:3.9K OHM,5%,0.2W	57668	TR20JE 03K9
A10R477	322-3284-00			RES,FXD,FILM:8.87K OHM,1%,0.2W,TC=TO	57668	CRB20 FXE 8K87
A10R478	322-3232-00			RES,FXD,FILM:2.55K OHM,1%,0.2W,TC=TO	80009	322-3232-00
A10R479	322-3143-00			RES,FXD,FILM:301 OHM,1%,0.2W,TC=TO	57668	CRB20 FXE 301E
A10R480	313-1051-00			RES,FXD,FILM:5.1 OHM,5%,0.2W	57668	TR20JT68 05E1
A10R481	313-1051-00			RES,FXD,FILM:5.1 OHM,5%,0.2W	57668	TR20JT68 05E1
A10R483	313-1151-00			RES,FXD,FILM:150 OHM,5%,0.2W	57668	TR20JE150E
A10R484	313-1202-00			RES,FXD,FILM:2K OHM,5%,0.2W	57668	TR20JE02K0
A10R485	313-1392-00			RES,FXD,FILM:3.9K OHM,5%,0.2W	57668	TR20JE 03K9
A10R486	313-1512-00			RES,FXD,FILM:5.1K OHM,5%,0.2W	57668	TR20JE 5K1
A10R487	313-1331-00	B010100	B010599	RES,FXD,FILM:330 OHM,5%,0.2W	57668	TR20JE 330E
A10R487	313-1027-00	B010600		RES,FXD,FILM:2.7 OHM,5%,0.2W	57668	TR20JE 02E7
A10R490	313-1511-00			RES,FXD,FILM:510 OHM,5%,0.2W	57668	TR20JT68 510E
A10R491	313-1511-00			RES,FXD,FILM:510 OHM,5%,0.2W	57668	TR20JT68 510E
A10R492	313-1511-00			RES,FXD,FILM:510 OHM,5%,0.2W	57668	TR20JT68 510E
A10R493	313-1511-00			RES,FXD,FILM:510 OHM,5%,0.2W	57668	TR20JT68 510E
A10R494	313-1511-00			RES,FXD,FILM:510 OHM,5%,0.2W	57668	TR20JT68 510E
A10R495	313-1511-00			RES,FXD,FILM:510 OHM,5%,0.2W	57668	TR20JT68 510E
A10R496	313-1511-00			RES,FXD,FILM:510 OHM,5%,0.2W	57668	TR20JT68 510E
A10R497	313-1511-00			RES,FXD,FILM:510 OHM,5%,0.2W	57668	TR20JT68 510E
A10R498	313-1511-00			RES,FXD,FILM:510 OHM,5%,0.2W	57668	TR20JT68 510E
A10R501	307-0446-00			RES NTWK,FXD,FI:10K OHM,20%,(9)RES	11236	750-101-R10K
A10R502	313-1103-00			RES,FXD,FILM:10K OHM,5%,0.2W	57668	TR20JE10K0
A10R503	313-1103-00			RES,FXD,FILM:10K OHM,5%,0.2W	57668	TR20JE10K0
A10R504	313-1101-00			RES,FXD,FILM:100 OHM,5%,0.2W	57668	TR20JE100E
A10R505	313-1103-00			RES,FXD,FILM:10K OHM,5%,0.2W	57668	TR20JE10K0
A10R506	313-1103-00			RES,FXD,FILM:10K OHM,5%,0.2W	57668	TR20JE10K0
A10R507	313-1103-00			RES,FXD,FILM:10K OHM,5%,0.2W	57668	TR20JE10K0
A10R508	313-1103-00			RES,FXD,FILM:10K OHM,5%,0.2W	57668	TR20JE10K0
A10R510	313-1103-00			RES,FXD,FILM:10K OHM,5%,0.2W	57668	TR20JE10K0
A10R512	313-1103-00			RES,FXD,FILM:10K OHM,5%,0.2W	57668	TR20JE10K0
A10R601	313-1102-00			RES,FXD,FILM:1K OHM,5%,0.2W	57668	TR20JE01K0
A10R602	322-3193-00			RES,FXD,FILM:1K OHM,1%,0.2W,TC=TO	57668	CRB20 FXE 1K00
A10R603	322-3193-00			RES,FXD,FILM:1K OHM,1%,0.2W,TC=TO	57668	CRB20 FXE 1K00
A10R604	322-3231-00			RES,FXD,FILM:2.49K OHM,1%,0.2W,TC=TO	57668	CRB20 FXE 2K49
A10R605	322-3193-00			RES,FXD,FILM:1K OHM,1%,0.2W,TC=TO	57668	CRB20 FXE 1K00
A10R606	313-1102-00			RES,FXD,FILM:1K OHM,5%,0.2W	57668	TR20JE01K0
A10R609	313-1101-00			RES,FXD,FILM:100 OHM,5%,0.2W	57668	TR20JE100E
A10R610	313-1391-00			RES,FXD,FILM:390 OHM,5%,0.2W	57668	TR20JE 390E
A10R611	313-1101-00			RES,FXD,FILM:100 OHM,5%,0.2W	57668	TR20JE100E
A10R612	313-1391-00			RES,FXD,FILM:390 OHM,5%,0.2W	57668	TR20JE 390E
A10R613	313-1101-00			RES,FXD,FILM:100 OHM,5%,0.2W	57668	TR20JE100E
A10R614	313-1391-00			RES,FXD,FILM:390 OHM,5%,0.2W	57668	TR20JE 390E

Replaceable Electrical Parts - 2247A Service

Component No.	Tektronix Part No.	Serial/Assembly No. Effective	Discont	Name & Description	Mfr. Code	Mfr. Part No.
A10R615	313-1471-00			RES,FXD,FILM:470 OHM,5%,0.2W	57668	TR20JE 470E
A10R616	313-1471-00			RES,FXD,FILM:470 OHM,5%,0.2W	57668	TR20JE 470E
A10R617	313-1471-00			RES,FXD,FILM:470 OHM,5%,0.2W	57668	TR20JE 470E
A10R618	313-1821-00			RES,FXD,FILM:820 OHM,5%,0.2W	57668	TR20JE 820E
A10R619	313-1821-00			RES,FXD,FILM:820 OHM,5%,0.2W	57668	TR20JE 820E
A10R620	313-1821-00			RES,FXD,FILM:820 OHM,5%,0.2W	57668	TR20JE 820E
A10R621	313-1302-00			RES,FXD,FILM:3K OHM,5%,0.2W	57668	TR20JE 03K0
A10R622	313-1302-00			RES,FXD,FILM:3K OHM,5%,0.2W	57668	TR20JE 03K0
A10R623	313-1302-00			RES,FXD,FILM:3K OHM,5%,0.2W	57668	TR20JE 03K0
A10R624	313-1102-00			RES,FXD,FILM:1K OHM,5%,0.2W	57668	TR20JE01K0
A10R625	313-1201-00			RES,FXD,FILM:200 OHM,5%,0.2W	57668	TR20JE200E
A10R626	313-1390-00			RES,FXD,FILM:39 OHM,5%,0.2W	57668	TR20JE 39E
A10R627	313-1390-00			RES,FXD,FILM:39 OHM,5%,0.2W	57668	TR20JE 39E
A10R628	307-0503-00			RES NTWK,FXD,FI:(9) 510 OHM,20%,0.125W	11236	750-101-R510
A10R630	313-1103-00			RES,FXD,FILM:10K OHM,5%,0.2W	57668	TR20JE10K0
A10R631	313-1102-00			RES,FXD,FILM:1K OHM,5%,0.2W	57668	TR20JE01K0
A10R636	313-1303-00			RES,FXD,FILM:30K OHM,5%,0.2W	57668	TR20JE 30K
A10R637	313-1822-00			RES,FXD,FILM:8.2K,OHM,5%,0.2W	57668	TR20JE 08K2
A10R638	313-1104-00			RES,FXD,FILM:100K OHM,5%,0.2W	57668	TR20JE100K
A10R639	313-1512-00			RES,FXD,FILM:5.1K OHM,5%,0.2W	57668	TR20JE 5K1
A10R640	313-1512-00			RES,FXD,FILM:5.1K OHM,5%,0.2W	57668	TR20JE 5K1
A10R641	313-1821-00			RES,FXD,FILM:820 OHM,5%,0.2W	57668	TR20JE 820E
A10R642	313-1821-00			RES,FXD,FILM:820 OHM,5%,0.2W	57668	TR20JE 820E
A10R643	313-1562-00			RES,FXD,FILM:5.6K OHM,5%,0.2W	57668	TR20JE 05K6
A10R644	313-1562-00			RES,FXD,FILM:5.6K OHM,5%,0.2W	57668	TR20JE 05K6
A10R645	313-1562-00			RES,FXD,FILM:5.6K OHM,5%,0.2W	57668	TR20JE 05K6
A10R646	313-1562-00			RES,FXD,FILM:5.6K OHM,5%,0.2W	57668	TR20JE 05K6
A10R647	313-1821-00			RES,FXD,FILM:820 OHM,5%,0.2W	57668	TR20JE 820E
A10R648	313-1471-00			RES,FXD,FILM:470 OHM,5%,0.2W	57668	TR20JE 470E
A10R649	313-1302-00			RES,FXD,FILM:3K OHM,5%,0.2W	57668	TR20JE 03K0
A10R650	313-1751-00			RES,FXD,FILM:750 OHM,5%,0.2W	57668	TR20JE 750E
A10R651	313-1331-00			RES,FXD,FILM:330 OHM,5%,0.2W	57668	TR20JE 330E
A10R652	313-1331-00			RES,FXD,FILM:330 OHM,5%,0.2W	57668	TR20JE 330E
A10R653	313-1471-00			RES,FXD,FILM:470 OHM,5%,0.2W	57668	TR20JE 470E
A10R654	313-1302-00			RES,FXD,FILM:3K OHM,5%,0.2W	57668	TR20JE 03K0
A10R655	313-1821-00			RES,FXD,FILM:820 OHM,5%,0.2W	57668	TR20JE 820E
A10R656	313-1201-00			RES,FXD,FILM:200 OHM,5%,0.2W	57668	TR20JE200E
A10R657	313-1201-00			RES,FXD,FILM:200 OHM,5%,0.2W	57668	TR20JE200E
A10R658	313-1821-00			RES,FXD,FILM:820 OHM,5%,0.2W	57668	TR20JE 820E
A10R659	313-1821-00			RES,FXD,FILM:820 OHM,5%,0.2W	57668	TR20JE 820E
A10R662	313-1393-00			RES,FXD,FILM:39K OHM,5%,0.2W	57668	TR20JE 39K
A10R663	313-1393-00			RES,FXD,FILM:39K OHM,5%,0.2W	57668	TR20JE 39K
A10R664	313-1393-00			RES,FXD,FILM:39K OHM,5%,0.2W	57668	TR20JE 39K
A10R665	313-1393-00			RES,FXD,FILM:39K OHM,5%,0.2W	57668	TR20JE 39K
A10R666	313-1393-00			RES,FXD,FILM:39K OHM,5%,0.2W	57668	TR20JE 39K
A10R669	313-1511-00			RES,FXD,FILM:510 OHM,5%,0.2W	57668	TR20JT68 510E
A10R670	313-1511-00			RES,FXD,FILM:510 OHM,5%,0.2W	57668	TR20JT68 510E
A10R671	313-1200-00			RES,FXD,FILM:20 OHM,5%,0.2W	57668	TR20JE20E
A10R672	313-1333-00			RES,FXD,FILM:33K OHM,5%,0.2W	57668	TR20JE 33K
A10R673	313-1331-00			RES,FXD,FILM:330 OHM,5%,0.2W	57668	TR20JE 330E
A10R674	313-1201-00			RES,FXD,FILM:200 OHM,5%,0.2W	57668	TR20JE200E
A10R680	313-1511-00			RES,FXD,FILM:510 OHM,5%,0.2W	57668	TR20JT68 510E
A10R681	313-1161-00			RES,FXD,FILM:160 OHM,5%,0.2W	57668	TR20JE160E
A10R682	313-1511-00			RES,FXD,FILM:510 OHM,5%,0.2W	57668	TR20JT68 510E
A10R683	313-1511-00			RES,FXD,FILM:510 OHM,5%,0.2W	57668	TR20JT68 510E
A10R684	313-1161-00			RES,FXD,FILM:160 OHM,5%,0.2W	57668	TR20JE160E
A10R685	313-1511-00			RES,FXD,FILM:510 OHM,5%,0.2W	57668	TR20JT68 510E
A10R686	313-1511-00			RES,FXD,FILM:510 OHM,5%,0.2W	57668	TR20JT68 510E

Component No.	Tektronix Part No.	Serial/Assembly No. Effective Dscont	Name & Description	Mfr. Code	Mfr. Part No.
A10R687	313-1511-00		RES,FXD,FILM:510 OHM,5%,0.2W	57668	TR20JT68 510E
A10R688	313-1511-00		RES,FXD,FILM:510 OHM,5%,0.2W	57668	TR20JT68 510E
A10R689	313-1750-00		RES,FXD,FILM:75 OHM,5%,0.2W	57668	TR20JE 75E
A10R690	313-1750-00		RES,FXD,FILM:75 OHM,5%,0.2W	57668	TR20JE 75E
A10R691	313-1750-00		RES,FXD,FILM:75 OHM,5%,0.2W	57668	TR20JE 75E
A10R692	313-1750-00		RES,FXD,FILM:75 OHM,5%,0.2W	57668	TR20JE 75E
A10R693	313-1750-00		RES,FXD,FILM:75 OHM,5%,0.2W	57668	TR20JE 75E
A10R694	313-1750-00		RES,FXD,FILM:75 OHM,5%,0.2W	57668	TR20JE 75E
A10R701	322-3226-00		RES,FXD,FILM:2.21K OHM,1%,0.2W,TC=TO	57668	CRB20 FXE 2K21
A10R702	322-3226-00		RES,FXD,FILM:2.21K OHM,1%,0.2W,TC=TO	57668	CRB20 FXE 2K21
A10R703	311-2230-00		RES,VAR,NONWV:TRMR,500 OHM,20%,0.50 LINEAR	TK1450	GF06UT 500
A10R706	322-3085-00		RES,FXD,FILM:75 OHM,1%,0.2W,TC=TO	57668	CRB20 FXE 75E0
A10R707	322-3085-00		RES,FXD,FILM:75 OHM,1%,0.2W,TC=TO	57668	CRB20 FXE 75E0
A10R708	307-2130-00		RES NTWK,FXD,FI:DUAL LOAD RESISTOR	80009	307-2130-00
A10R709	313-1027-00		RES,FXD,FILM:2.7 OHM,5%,0.2W	57668	TR20JE 02E7
A10R710	313-1134-00		RES,FXD,FILM:130K OHM 5%,0.2W	57668	TR20JT68 130K
A10R711	313-1100-00		RES,FXD,FILM:10 OHM,5%,0.2W	57668	TR20JE10E0
A10R712	313-1100-00		RES,FXD,FILM:10 OHM,5%,0.2W	57668	TR20JE10E0
A10R715	313-1103-00		RES,FXD,FILM:10K OHM,5%,0.2W	57668	TR20JE10K0
A10R716	313-1103-00		RES,FXD,FILM:10K OHM,5%,0.2W	57668	TR20JE10K0
A10R717	313-1102-00		RES,FXD,FILM:1K OHM,5%,0.2W	57668	TR20JE01K0
A10R718	313-1102-00		RES,FXD,FILM:1K OHM,5%,0.2W	57668	TR20JE01K0
A10R719	313-1200-00		RES,FXD,FILM:20 OHM,5%,0.2W	57668	TR20JE20E
A10R720	313-1200-00		RES,FXD,FILM:20 OHM,5%,0.2W	57668	TR20JE20E
A10R721	313-1134-00		RES,FXD,FILM:130K OHM 5%,0.2W	57668	TR20JT68 130K
A10R722	313-1134-00		RES,FXD,FILM:130K OHM 5%,0.2W	57668	TR20JT68 130K
A10R723	313-1027-00		RES,FXD,FILM:2.7 OHM,5%,0.2W	57668	TR20JE 02E7
A10R724	311-2234-00		RES,VAR,NONWV:TRMR,5K OHM,20%,0.5W LINEAR TA PE & REEL	TK1450	GF06UT 5K
A10R725	313-1102-00		RES,FXD,FILM:1K OHM,5%,0.2W	57668	TR20JE01K0
A10R726	313-1103-00		RES,FXD,FILM:10K OHM,5%,0.2W	57668	TR20JE10K0
A10R727	313-1104-00		RES,FXD,FILM:100K OHM,5%,0.2W	57668	TR20JE100K
A10R728	313-1824-00		RES,FXD,FILM:820K OHM,0.2W,5%	91637	CCF50-2-82002J
A10R729	313-1202-00		RES,FXD,FILM:2K OHM,5%,0.2W	57668	TR20JE02K0
A10R730	313-1102-00		RES,FXD,FILM:1K OHM,5%,0.2W	57668	TR20JE01K0
A10R731	313-1750-00		RES,FXD,FILM:75 OHM,5%,0.2W	57668	TR20JE 75E
A10R732	313-1750-00		RES,FXD,FILM:75 OHM,5%,0.2W	57668	TR20JE 75E
A10R733	313-1027-00		RES,FXD,FILM:2.7 OHM,5%,0.2W	57668	TR20JE 02E7
A10R734	313-1120-00		RES,FXD,FILM:12 OHM,5%,0.2W	57668	TR20JE12E0
A10R801	313-1681-00		RES,FXD,FILM:680 OHM,5%,0.2W	57668	TR20JE 680E
A10R802	313-1750-00		RES,FXD,FILM:75 OHM,5%,0.2W	57668	TR20JE 75E
A10R803	313-1272-00		RES,FXD,FILM:2.7K OHM,5%,0.2W	57668	TR20JE 02K7
A10R804	313-1273-00		RES,FXD,FILM:27K OHM,5%,0.2W	57668	TR20JE 27K
A10R805	313-1273-00		RES,FXD,FILM:27K OHM,5%,0.2W	57668	TR20JE 27K
A10R806	323-0310-00		RES,FXD,FILM:16.5K OHM,1%,0.5W,TC=TO	75042	CECT0-1652F
A10R807	313-1750-00		RES,FXD,FILM:75 OHM,5%,0.2W	57668	TR20JE 75E
A10R808	313-1272-00		RES,FXD,FILM:2.7K OHM,5%,0.2W	57668	TR20JE 02K7
A10R809	311-2234-00		RES,VAR,NONWV:TRMR,5K OHM,20%,0.5W LINEAR TA PE & REEL	TK1450	GF06UT 5K
A10R810	313-1272-00		RES,FXD,FILM:2.7K OHM,5%,0.2W	57668	TR20JE 02K7
A10R811	322-3265-00		RES,FXD,FILM:5.62K OHM,1%,0.2W,TC=TO	80009	322-3265-00
A10R812	322-3265-00		RES,FXD,FILM:5.62K OHM,1%,0.2W,TC=TO	80009	322-3265-00
A10R813	313-1272-00		RES,FXD,FILM:2.7K OHM,5%,0.2W	57668	TR20JE 02K7
A10R814	313-1272-00		RES,FXD,FILM:2.7K OHM,5%,0.2W	57668	TR20JE 02K7
A10R820	322-3402-00		RES,FXD,FILM:150K OHM,1%,0.2W,TC=TO	57668	CRB20 FXE 150K
A10R821	322-3402-00		RES,FXD,FILM:150K OHM,1%,0.2W,TC=TO	57668	CRB20 FXE 150K
A10R822	322-3265-00		RES,FXD,FILM:5.62K OHM,1%,0.2W,TC=TO	80009	322-3265-00

Replaceable Electrical Parts - 2247A Service

Component No.	Tektronix Part No.	Serial/Assembly No. Effective	Dscont	Name & Description	Mfr. Code	Mfr. Part No.
A10R823	311-2230-00			RES,VAR, NONWV:TRMR,500 OHM,20%,0.5W LINEAR	TK1450	GF06UT 500
A10R825	311-2234-00			RES,VAR, NONWV:TRMR,5K OHM,20%,0.5W LINEARTA PE & REEL	TK1450	GF06UT 5K
A10R826	311-2234-00			RES,VAR, NONWV:TRMR,5K OHM,20%,0.5W LINEARTA PE & REEL	TK1450	GF06UT 5K
A10R827	311-2229-00			RES,VAR, NONWV:TRMR,250 OHM,20%,0.5W LINEAR	TK1450	GF06UT 250
A10R828	313-1133-00			RES,FXD, FILM:13K,1%,0.2W	91637	
A10R829	313-1133-00			RES,FXD, FILM:13K,1%,0.2W	91637	
A10R830	313-1133-00			RES,FXD, FILM:13K,1%,0.2W	91637	
A10R831	313-1133-00			RES,FXD, FILM:13K,1%,0.2W	91637	
A10R836	322-3152-00			RES,FXD, FILM:374 OHM,1%,0.2W,TC=TO	57668	CRB20 FXE 374E
A10R837	313-1100-00			RES,FXD, FILM:10 OHM,5%,0.2W	57668	TR20JE10E0
A10R854	313-1201-00			RES,FXD, FILM:200 OHM,5%,0.2W	57668	TR20JE200E
A10R855	313-1201-00			RES,FXD, FILM:200 OHM,5%,0.2W	57668	TR20JE200E
A10R856	322-3289-00			RES,FXD, FILM:10K OHM,1%,0.2W,TC=TO	57668	CRB20 FXE 10K0
A10R857	322-3265-00			RES,FXD, FILM:5.62K OHM,1%,0.2W,TC=TO	80009	322-3265-00
A10R860	313-1103-00			RES,FXD, FILM:10K OHM,5%,0.2W	57668	TR20JE10K0
A10R861	313-1272-00			RES,FXD, FILM:2.7K OHM,5%,0.2W	57668	TR20JE 02K7
A10R862	322-3083-00	B010100	B010599	RES,FXD, FILM:71.5 OHM,1%,0.2W,TC=TO	57668	CRB20 FXE 71E5
A10R862	322-3077-00	B010600		RES,FXD, FILM:61.9 OHM,1%,0.2W,TC=TO	91637	CCF1G61R90F 0F
A10R863	313-1201-00	B010100	B010599	RES,FXD, FILM:200 OHM,5%,0.2W	57668	TR20JE200E
A10R863	313-1271-00	B010600		RES,FXD, FILM:270 OHM,5%,0.2W	57668	TR20JE 270E
A10R871	313-1103-00			RES,FXD, FILM:10K OHM,5%,0.2W	57668	TR20JE10K0
A10R872	313-1200-00	B010100	B010599	RES,FXD, FILM:20 OHM,5%,0.2W	57668	TR20JE20E
A10R872	313-1510-00	B010600		RES,FXD, FILM:51 OHM,5%,0.2W	80009	313-1510-00
A10R873	313-1201-00	B010100	B010599	RES,FXD, FILM:200 OHM,5%,0.2W	57668	TR20JE200E
A10R873	313-1271-00	B010600		RES,FXD, FILM:270 OHM,5%,0.2W	57668	TR20JE 270E
A10R891	313-1681-00			RES,FXD, FILM:680 OHM,5%,0.2W	57668	TR20JE 680E
A10R892	313-1750-00			RES,FXD, FILM:75 OHM,5%,0.2W	57668	TR20JE 75E
A10R893	313-1391-00			RES,FXD, FILM:390 OHM,5%,0.2W	57668	TR20JE 390E
A10R894	313-1100-00			RES,FXD, FILM:10 OHM,5%,0.2W	57668	TR20JE10E0
A10R896	323-0310-00			RES,FXD, FILM:16.5K OHM,1%,0.5W,TC=TO	75042	CECT0-1652F
A10R897	313-1100-00			RES,FXD, FILM:10 OHM,5%,0.2W	57668	TR20JE10E0
A10R898	313-1100-00			RES,FXD, FILM:10 OHM,5%,0.2W	57668	TR20JE10E0
A10R906	313-1120-00			RES,FXD, FILM:12 OHM,5%,0.2W	57668	TR20JE12E0
A10R907	313-1120-00			RES,FXD, FILM:12 OHM,5%,0.2W	57668	TR20JE12E0
A10R908	313-1120-00			RES,FXD, FILM:12 OHM,5%,0.2W	57668	TR20JE12E0
A10R909	313-1101-00			RES,FXD, FILM:100 OHM,5%,0.2W	57668	TR20JE100E
A10R910	313-1101-00			RES,FXD, FILM:100 OHM,5%,0.2W	57668	TR20JE100E
A10R911	311-1239-00			RES,VAR, NONWV:TRMR,2.5K OHM,0.5W	32997	3386X-T07-252
A10R915	322-3289-00			RES,FXD, FILM:10K OHM,1%,0.2W,TC=TO	57668	CRB20 FXE 10K0
A10R916	322-3289-00			RES,FXD, FILM:10K OHM,1%,0.2W,TC=TO	57668	CRB20 FXE 10K0
A10R920	311-2228-00			RES,VAR, NONWV:TRMR,200 OHM,20%,0.5W LINEAR	80009	311-2228-00
A10R921	307-2131-00			RES NTWK,FXD, FI:PRECISION VOLTAGE DIVIDER	80009	307-2131-00
A10R922	313-1103-00			RES,FXD, FILM:10K OHM,5%,0.2W	57668	TR20JE10K0
A10R923	313-1103-00			RES,FXD, FILM:10K OHM,5%,0.2W	57668	TR20JE10K0
A10R924	313-1103-00			RES,FXD, FILM:10K OHM,5%,0.2W	57668	TR20JE10K0
A10R930	313-1751-00			RES,FXD, FILM:750 OHM,5%,0.2W	57668	TR20JE 750E
A10R931	322-3193-02			RES,FXD, FILM:1K OHM,0.5%,0.2W,TC=T2	57668	CRB20 DYE 1K00
A10R932	322-3239-03			RES,FXD, FILM:3.01K OHM,0.25%,0.2W,TC=T2 MI, SMALL BODY	57668	CRB20 CYE 3K01
A10R933	313-1272-00			RES,FXD, FILM:2.7K OHM,5%,0.2W	57668	TR20JE 02K7
A10R934	313-1122-00			RES,FXD, FILM:1.2K OHM,5%,0.2W	57668	TR20JE01K2
A10R935	313-1243-00			RES,FXD, FILM:24K OHM,5%,0.2W	80009	313-1243-00
A10R936	322-3489-02			RES,FXD, FILM:3.52K OHM,0.2W,5%	57668	CRB20 DYE 3K52
A10R937	322-3126-02			RES,FXD, FILM:200 OHM,0.5%,0.2W,TC=T2	80009	322-3126-02
A10R938	313-1752-00			RES,FXD, FILM:7.5K OHM,5%,0.2W	57668	TR20JE 07K5
A10R939	313-1152-00			RES,FXD, FILM:1.5K OHM,5%,0.2W	57668	TR20JE01K5

Component No.	Tektronix Part No.	Serial/Assembly No. Effective Discnt	Name & Description	Mfr. Code	Mfr. Part No.
A10R940	313-1122-00		RES, FXD, FILM: 1.2K OHM, 5%, 0.2W	57668	TR20JE01K2
A10R1001	322-3232-00		RES, FXD, FILM: 2.55K OHM, 1%, 0.2W, TC=TO	80009	322-3232-00
A10R1002	322-3232-00		RES, FXD, FILM: 2.55K OHM, 1%, 0.2W, TC=TO	80009	322-3232-00
A10R1003	313-1512-00		RES, FXD, FILM: 5.1K OHM, 5%, 0.2W	57668	TR20JE 5K1
A10R1004	322-3232-00		RES, FXD, FILM: 2.55K OHM, 1%, 0.2W, TC=TO	80009	322-3232-00
A10R1005	322-3251-00		RES, FXD, FILM: 4.02K OHM, 1%, 0.2W, TC=TO	57668	CRB20 FXE 4K02
A10R1006	322-3184-00		RES, FXD, FILM: 806 OHM, 1%, 0.2W, TC=TO	57668	CRB20 FXE 806E
A10R1007	322-3251-00		RES, FXD, FILM: 4.02K OHM, 1%, 0.2W, TC=TO	57668	CRB20 FXE 4K02
A10R1008	322-3184-00		RES, FXD, FILM: 806 OHM, 1%, 0.2W, TC=TO	57668	CRB20 FXE 806E
A10R1009	313-1103-00		RES, FXD, FILM: 10K OHM, 5%, 0.2W	57668	TR20JE10K0
A10R1010	313-1103-00		RES, FXD, FILM: 10K OHM, 5%, 0.2W	57668	TR20JE10K0
A10R1020	313-1272-00		RES, FXD, FILM: 2.7K OHM, 5%, 0.2W	57668	TR20JE 02K7
A10R1021	313-1512-00		RES, FXD, FILM: 5.1K OHM, 5%, 0.2W	57668	TR20JE 5K1
A10R1022	313-1272-00		RES, FXD, FILM: 2.7K OHM, 5%, 0.2W	57668	TR20JE 02K7
A10R1023	313-1512-00		RES, FXD, FILM: 5.1K OHM, 5%, 0.2W	57668	TR20JE 5K1
A10R1024	313-1272-00		RES, FXD, FILM: 2.7K OHM, 5%, 0.2W	57668	TR20JE 02K7
A10R1025	313-1512-00		RES, FXD, FILM: 5.1K OHM, 5%, 0.2W	57668	TR20JE 5K1
A10R1026	313-1100-00		RES, FXD, FILM: 10 OHM, 5%, 0.2W	57668	TR20JE10E0
A10R1027	313-1100-00		RES, FXD, FILM: 10 OHM, 5%, 0.2W	57668	TR20JE10E0
A10R1028	313-1102-00		RES, FXD, FILM: 1K OHM, 5%, 0.2W	57668	TR20JE01K0
A10R1103	313-1102-00		RES, FXD, FILM: 1K OHM, 5%, 0.2W	57668	TR20JE01K0
A10R1104	313-1682-00		RES, FXD, FILM: 6.8K OHM, 5%, 0.2W	57668	TR20JE 06K8
A10R1105	313-1511-00		RES, FXD, FILM: 510 OHM, 5%, 0.2W	57668	TR20JT68 510E
A10R1106	313-1511-00		RES, FXD, FILM: 510 OHM, 5%, 0.2W	57668	TR20JT68 510E
A10R1108	313-1100-00	B020546	RES, FXD, FILM: 10 OHM, 5%, 0.2W	57668	TR20JE10E0
A10R1110	313-1682-00		RES, FXD, FILM: 6.8K OHM, 5%, 0.2W	57668	TR20JE 06K8
A10R1111	313-1303-00		RES, FXD, FILM: 30K OHM, 5%, 0.2W	57668	TR20JE 30K
A10R1112	313-1302-00		RES, FXD, FILM: 3K OHM, 5%, 0.2W	57668	TR20JE 03K0
A10R1113	313-1101-00		RES, FXD, FILM: 100 OHM, 5%, 0.2W	57668	TR20JE100E
A10R1114	313-1103-00		RES, FXD, FILM: 10K OHM, 5%, 0.2W	57668	TR20JE10K0
A10R1115	313-1682-00		RES, FXD, FILM: 6.8K OHM, 5%, 0.2W	57668	TR20JE 06K8
A10R1116	313-1102-00		RES, FXD, FILM: 1K OHM, 5%, 0.2W	57668	TR20JE01K0
A10R1117	313-1162-00		RES, FXD, FILM: 1.6K OHM, 5%, 0.2W	57668	TR20JT681K6
A10R1118	313-1751-00		RES, FXD, FILM: 750 OHM, 5%, 0.2W	57668	TR20JE 750E
A10R1120	313-1682-00		RES, FXD, FILM: 6.8K OHM, 5%, 0.2W	57668	TR20JE 06K8
A10R1121	313-1303-00		RES, FXD, FILM: 30K OHM, 5%, 0.2W	57668	TR20JE 30K
A10R1122	313-1302-00		RES, FXD, FILM: 3K OHM, 5%, 0.2W	57668	TR20JE 03K0
A10R1123	313-1101-00		RES, FXD, FILM: 100 OHM, 5%, 0.2W	57668	TR20JE100E
A10R1124	313-1103-00		RES, FXD, FILM: 10K OHM, 5%, 0.2W	57668	TR20JE10K0
A10R1125	313-1682-00		RES, FXD, FILM: 6.8K OHM, 5%, 0.2W	57668	TR20JE 06K8
A10R1126	313-1102-00		RES, FXD, FILM: 1K OHM, 5%, 0.2W	57668	TR20JE01K0
A10R1127	313-1162-00		RES, FXD, FILM: 1.6K OHM, 5%, 0.2W	57668	TR20JT681K6
A10R1128	313-1751-00		RES, FXD, FILM: 750 OHM, 5%, 0.2W	57668	TR20JE 750E
A10R1131	313-1472-00		RES, FXD, FILM: 4.7K OHM, 5%, 0.2W	57668	TR20JE 04K7
A10R1132	313-1223-00		RES, FXD, FILM: 22K OHM, 5%, 0.2W	57668	TR20JE 22K
A10R1133	313-1104-00		RES, FXD, FILM: 100K OHM, 5%, 0.2W	57668	TR20JE100K
A10R1134	313-1472-00		RES, FXD, FILM: 4.7K OHM, 5%, 0.2W	57668	TR20JE 04K7
A10R1135	313-1204-00		RES, FXD, FILM: 200K, 5%, 0.2W	57668	TR20JE 200K
A10R1136	313-1204-00		RES, FXD, FILM: 200K, 5%, 0.2W	57668	TR20JE 200K
A10R1142	313-1223-00		RES, FXD, FILM: 22K OHM, 5%, 0.2W	57668	TR20JE 22K
A10R1143	313-1102-00		RES, FXD, FILM: 1K OHM, 5%, 0.2W	57668	TR20JE01K0
A10R1144	313-1753-00		RES, FXD, FILM: 75K OHM, 5%, 0.2W	57668	TR20JE 75K
A10R1145	313-1102-00		RES, FXD, FILM: 1K OHM, 5%, 0.2W	57668	TR20JE01K0
A10R1150	313-1102-00		RES, FXD, FILM: 1K OHM, 5%, 0.2W	57668	TR20JE01K0
A10R1154	315-0205-00		RES, FXD, FILM: 2M OHM, 5%, 0.25W	01121	CB2055
A10R1155	315-0205-00		RES, FXD, FILM: 2M OHM, 5%, 0.25W	01121	CB2055
A10R1158	313-1100-00		RES, FXD, FILM: 10 OHM, 5%, 0.2W	57668	TR20JE10E0
A10R1159	313-1100-00		RES, FXD, FILM: 10 OHM, 5%, 0.2W	57668	TR20JE10E0

Replaceable Electrical Parts - 2247A Service

Component No.	Tektronix Part No.	Serial/Assembly No. Effective Dscnt	Name & Description	Mfr. Code	Mfr. Part No.
A10R1160	313-1100-00		RES,FXD,FILM:10 OHM,5%,0.2W	57668	TR20JE10E0
A10R1162	313-1302-00		RES,FXD,FILM:3K OHM,5%,0.2W	57668	TR20JE 03K0
A10R1163	313-1152-00		RES,FXD,FILM:1.5K OHM,5%,0.2W	57668	TR20JE01K5
A10R1170	313-1152-00		RES,FXD,FILM:1.5K OHM,5%,0.2W	57668	TR20JE01K5
A10R2701	322-3112-00		RES,FXD,FILM:143 OHM,1%,0.2W,TC=TO	80009	322-3112-00
A10R2702	313-1393-00		RES,FXD,FILM:39K OHM,5%,0.2W	57668	TR20JE 39K
A10R2703	322-3282-00		RES,FXD,FILM:8.45K OHM,1%,0.2W,TC=TO	80009	322-3282-00
A10R2704	322-3164-00		RES,FXD,FILM:499 OHM,1%,0.2W,TC=TO	57668	CRB20 FXE 499E
A10R2705	313-1102-00		RES,FXD,FILM:1K OHM,5%,0.2W	57668	TR20JE01K0
A10R2706	313-1103-00		RES,FXD,FILM:10K OHM,5%,0.2W	57668	TR20JE10K0
A10R2708	322-3289-00		RES,FXD,FILM:10K OHM,1%,0.2W,TC=TO	57668	CRB20 FXE 10K0
A10R2709	322-3289-00		RES,FXD,FILM:10K OHM,1%,0.2W,TC=TO	57668	CRB20 FXE 10K0
A10R2710	313-1331-00		RES,FXD,FILM:330 OHM,5%,0.2W	57668	TR20JE 330E
A10R2711	313-1333-00		RES,FXD,FILM:33K OHM,5%,0.2W	57668	TR20JE 33K
A10R2712	313-1333-00		RES,FXD,FILM:33K OHM,5%,0.2W	57668	TR20JE 33K
A10R2713	313-1333-00		RES,FXD,FILM:33K OHM,5%,0.2W	57668	TR20JE 33K
A10R2714	313-1333-00		RES,FXD,FILM:33K OHM,5%,0.2W	57668	TR20JE 33K
A10R2715	313-1104-00		RES,FXD,FILM:100K OHM,5%,0.2W	57668	TR20JE100K
A10R2716	313-1333-00		RES,FXD,FILM:33K OHM,5%,0.2W	57668	TR20JE 33K
A10R2717	313-1562-00		RES,FXD,FILM:5.6K OHM,5%,0.2W	57668	TR20JE 05K6
A10R2718	315-0750-00		RES,FXD,FILM:75 OHM,5%,0.25W	57668	NTR25J-E75E0
A10R2719	311-2236-00		RES,VAR,NONWV:TRMR,20K OHM,20%,0.5W LINEAR	TK1450	GF06UT 20K
A10R2720	315-0203-00		RES,FXD,FILM:20K OHM,5%,0.25W	57668	NTR25J-E 20K
A10R2721	315-0472-00		RES,FXD,FILM:4.7K OHM,5%,0.25W	57668	NTR25J-E04K7
A10R2722	315-0244-00		RES,FXD,FILM:240K OHM,5%,0.25W	19701	5043CX240K0J
A10R2723	315-0511-00		RES,FXD,FILM:510 OHM,5%,0.25W	19701	5043CX510R0J
A10R2724	315-0625-00		RES,FXD,FILM:6.2M OHM,5%,0.25W	01121	CB6255
A10R2726	313-1101-00		RES,FXD,FILM:100 OHM,5%,0.2W	57668	TR20JE100E
A10R2727	322-3213-00		RES,FXD,FILM:1.62K OHM,1%,0.2W,TC=TO	57668	CRB20 FXE 1K62
A10R2728	313-1200-00		RES,FXD,FILM:20 OHM,5%,0.2W	57668	TR20JE20E
A10R2729	322-3210-00		RES,FXD,FILM:1.5K OHM,1%,0.2W,TC=TO	57668	CRB20 FXE 1K50
A10R2733	313-1102-00		RES,FXD,FILM:1K OHM,5%,0.2W	57668	TR20JE01K0
A10R2734	313-1101-00		RES,FXD,FILM:100 OHM,5%,0.2W	57668	TR20JE100E
A10R2735	315-0122-00		RES,FXD,FILM:1.2K OHM,5%,0.25W	57668	NTR25J-E01K2
A10R2736	301-0203-00		RES,FXD,FILM:20K OHM,5%,0.5W	19701	5053CX20K00J
A10R2737	313-1104-00		RES,FXD,FILM:100K OHM,5%,0.2W	57668	TR20JE100K
A10R2738	313-1333-00		RES,FXD,FILM:33K OHM,5%,0.2W	57668	TR20JE 33K
A10R2739	313-1752-00		RES,FXD,FILM:7.5K OHM,5%,0.2W	57668	TR20JE 07K5
A10R2740	315-0750-00		RES,FXD,FILM:75 OHM,5%,0.25W	57668	NTR25J-E75E0
A10R2741	315-0472-00		RES,FXD,FILM:4.7K OHM,5%,0.25W	57668	NTR25J-E04K7
A10R2742	315-0244-00		RES,FXD,FILM:240K OHM,5%,0.25W	19701	5043CX240K0J
A10R2743	315-0122-00		RES,FXD,FILM:1.2K OHM,5%,0.25W	57668	NTR25J-E01K2
A10R2745	315-0122-00		RES,FXD,FILM:1.2K OHM,5%,0.25W	57668	NTR25J-E01K2
A10R2750	315-0511-00		RES,FXD,FILM:510 OHM,5%,0.25W	19701	5043CX510R0J
A10R2751	315-0625-00		RES,FXD,FILM:6.2M OHM,5%,0.25W	01121	CB6255
A10R2758	311-1933-00		RES,VAR,NONWV:PNL,5M OHM,10%,0.5W	01121	23M909
A10R2760	307-2173-00		RES NTWK,FXD,FI:HIGH VOLTAGE,FINISHED	80009	307-2173-00
A10R2765	322-3188-00		RES,FXD,FILM:887 OHM,1%,0.2W,TC=TO	57668	CRB20 FXE 887E
A10R2783	313-1101-00		RES,FXD,FILM:100 OHM,5%,0.2W	57668	TR20JE100E
A10R2784	311-2239-00		RES,VAR,NONWV:TRMR,100K OHM,20%,0.5W LINEAR	TK1450	GF06UT 100K
A10R2785	313-1102-00		RES,FXD,FILM:1K OHM,5%,0.2W	57668	TR20JE01K0
A10R2786	313-1753-00		RES,FXD,FILM:75K OHM,5%,0.2W	57668	TR20JE 75K
A10R2787	313-1333-00		RES,FXD,FILM:33K OHM,5%,0.2W	57668	TR20JE 33K
A10R2788	311-2239-00		RES,VAR,NONWV:TRMR,100K OHM,20%,0.5W LINEAR	TK1450	GF06UT 100K
A10R2789	313-1102-00		RES,FXD,FILM:1K OHM,5%,0.2W	57668	TR20JE01K0
A10R2795	322-3268-00		RES,FXD,FILM:6.04K OHM,1%,0.2W,TC=TO	57668	CRB20 FXE 6K04
A10R2796	313-1100-00		RES,FXD,FILM:10 OHM,5%,0.2W	57668	TR20JE10E0

Component No.	Tektronix Part No.	Serial/Assembly No. Effective	Dscont	Name & Description	Mfr. Code	Mfr. Part No.
A10U112	165-2232-01			MICROCKT,LINER:BUFFER AMPLIFIER W/3 GAIN SETTINGS	80009	165-2232-01
A10U122	165-2232-01			MICROCKT,LINER:BUFFER AMPLIFIER W/3 GAIN SETTINGS	80009	165-2232-01
A10U171	156-0796-00			MICROCKT,DGTL:8 STG SHF & STORE BUS RGTR	02735	CD4094BF
A10U172	156-0796-00			MICROCKT,DGTL:8 STG SHF & STORE BUS RGTR	02735	CD4094BF
A10U173	156-0796-00			MICROCKT,DGTL:8 STG SHF & STORE BUS RGTR	02735	CD4094BF
A10U174	156-1190-00			MICROCKT,LINER:7 XSTR	02735	CA3082-98
A10U175	156-1190-00			MICROCKT,LINER:7 XSTR	02735	CA3082-98
A10U201	156-2571-00			MICROCKT,DGTL:HCMOS,ANALOG MUX,TPL,2 CHAN	80009	156-2571-00
A10U202	156-2571-00			MICROCKT,DGTL:HCMOS,ANALOG MUX,TPL,2 CHAN	80009	156-2571-00
A10U203	156-2667-00			MICROCKT,LINER:QUAD LOW PWR,OPERATIONAL AMPLIFIERS MC3403,14 DIP,MI	80009	156-2667-00
A10U210	234-0238-20			QUICK CHIP:VERTICAL PREAMP,PACKAGE IC	80009	234-0238-20
A10U220	234-0238-20			QUICK CHIP:VERTICAL PREAMP,PACKAGE IC	80009	234-0238-20
A10U230	234-0238-20			QUICK CHIP:VERTICAL PREAMP,PACKAGE IC	80009	234-0238-20
A10U240	234-0238-20			QUICK CHIP:VERTICAL PREAMP,PACKAGE IC	80009	234-0238-20
A10U260	156-0067-01			MICROCKT,LINER:OPNL AMPL,CHECKED	80009	156-0067-01
A10U280	156-1349-00			MICROCKT,LINER:DUAL INDEP DIFF AMPL	80009	156-1349-00
A10U301	156-2571-00			MICROCKT,DGTL:HCMOS,ANALOG MUX,TPL,2 CHAN	80009	156-2571-00
A10U302	156-0796-00			MICROCKT,DGTL:8 STG SHF & STORE BUS RGTR	02735	CD4094BF
A10U303	156-0796-00			MICROCKT,DGTL:8 STG SHF & STORE BUS RGTR	02735	CD4094BF
A10U304	156-2873-00			MICROCKT,LINER:DUAL BIFET,OPERATIONAL AMPLIFIER	80009	156-2873-00
A10U307	156-0514-00			IC,MISC:CMOS,ANALOG MUX;DUAL 4 CHANNEL;CD4052,DIP16.3	02735	CD4052BF-98
A10U308	156-0514-00			IC,MISC:CMOS,ANALOG MUX;DUAL 4 CHANNEL;CD4052,DIP16.3	02735	CD4052BF-98
A10U309	156-0158-07			MICROCKT,LINER:DUAL OPNL AMPL,SCREENED	01295	MC1458JG4
A10U310	156-0514-00			IC,MISC:CMOS,ANALOG MUX;DUAL 4 CHANNEL;CD4052,DIP16.3	02735	CD4052BF-98
A10U311	156-0514-00			IC,MISC:CMOS,ANALOG MUX;DUAL 4 CHANNEL;CD4052,DIP16.3	02735	CD4052BF-98
A10U313	156-1349-00			MICROCKT,LINER:DUAL INDEP DIFF AMPL	80009	156-1349-00
A10U315	156-1640-00			MICROCKT,DGTL:ECL,TPL LINE RCVR	04713	MC10H116(L OR P)
A10U316	156-0308-00			IC,DIGITAL:ECL,BUUFFER;QUAD DIFFERENTIAL LINE RECEIVER CERAMIC PKG;10115,DIP16.3	04713	MC10115L OR P
A10U421	234-0239-30	B010100	B010599	QUICK CHIP:TRIGGER IC PACKAGE	80009	234-0239-30
A10U421	234-0239-31	B010600		QUICK CHIP:TRIGGER CIRCUIT,28PLCC W/AU LEAD FRAME	80009	234-0239-31
A10U431	234-0239-30	B010100	B010599	QUICK CHIP:TRIGGER IC PACKAGE	80009	234-0239-30
A10U431	234-0239-31	B010600		QUICK CHIP:TRIGGER CIRCUIT,28PLCC W/AU LEAD FRAME	80009	234-0239-31
A10U441	156-2027-00			IC,DIGITAL:HCCMOS,GATES;HEX INV;74HC04,DIP14.3,TUBE	27014	MM74HC04N
A10U442	156-1640-00			MICROCKT,DGTL:ECL,TPL LINE RCVR	04713	MC10H116(L OR P)
A10U501	156-0469-00			IC,DIGITAL:LSTTL,DEMUX/DECODER;3-TO-8 DECODER;74LS138,DIP16.3,TUBE	01295	SN74LS138N
A10U502	156-0768-00			IC,DIGITAL:LSTTL,SHIFT REGISTER;8-BIT BIDIRECTIONAL UNIVERSAL;74LS194,DIP16.3 TUBE	01295	SN74LS194AN
A10U503	156-0804-00			IC,DIGITAL:LSTTL,LATCH;QUADRUPLE S-R;74LS279,DIP16.3,TUBE	04713	74LS279(N OR J)
A10U506	156-0513-00			IC,MISC:CMOS,ANALOG MUX;8 CHANNEL;CD4051,DIP16.3	04713	MC14051BCL
A10U600	156-2655-00			MICROCKT,DGTL:CMOS,SEMI CUSTOM,STD CELL,SLOW LOGIC	80009	156-2655-00
A10U601	156-1126-00			MICROCKT,LINER:VOLTAGE COMPARATOR	01295	LM311P
A10U602	156-2654-00			MICROCKT,DGTL:ECL,SEMI CUSTOM,FAST LOGIC	80009	156-2654-00

Replaceable Electrical Parts - 2247A Service

Component No.	Tektronix Part No.	Serial/Assembly No. Effective Discnt	Name & Description	Mfr. Code	Mfr. Part No.
A10U603	156-0631-00		MICROCKT,DGTL:ECL,QUAD 2 INP OR/NOR GATE	04713	MC10101(L OR P)
A10U604	156-0860-00		MICROCKT,DGTL:ECL,TRIPLE LINE RECEIVER	04713	MC10116L
A10U606	156-0140-00		MICROCKT,DGTL:TTL,HEX BUFFER/DRIVER	01295	SN7417N
A10U701	155-0322-00		MICROCKT,LINEAR:VERTICAL OUTPUT AMPLIFIER	80009	155-0322-00
A10U702	156-1126-00		MICROCKT,LINEAR:VOLTAGE COMPARATOR	01295	LM311P
A10U801	156-0158-07		MICROCKT,LINEAR:DUAL OPNL AMPL,SCREENED	01295	MC1458JG4
A10U802	234-0401-21		QUICK CHIP:GPS HORIZ PREAMP	80009	234-0401-21
A10U901	156-2702-00		MICROCKT,LINEAR:DUAL OP AMP,HIGH OUTPUT CURENT	80009	156-2702-00
A10U930	156-0158-07		MICROCKT,LINEAR:DUAL OPNL AMPL,SCREENED	01295	MC1458JG4
A10U931	156-2605-00		MICROCKT,DGTL:HCMOS,ANALOG MUX,8 CHANNEL	80009	156-2605-00
A10U932	156-1173-00		MICROCKT,LINEAR:VOLTAGE REFERENCE	04713	MC1403UDS
A10U1001	156-0495-00		MICROCKT,LINEAR:OPNL AMPL	01295	LM324N
A10U1101	156-2873-00		MICROCKT,LINEAR:DUAL BIFET,OPERATIONAL AMPLIFIER	80009	156-2873-00
A10U1102	156-1225-00		MICROCKT,LINEAR:DUAL COMPARATOR	01295	LM393P
A10U1103	156-0796-00		MICROCKT,DGTL:8 STG SHF & STORE BUS RGTR	02735	CD4094BF
A10U1104	156-0515-00		IC,MISC:CMOS,ANALOG MUX;TRIPLE SPDT;CD4053, DIP16.3	02735	CD4053BF
A10U1106	156-0515-00		IC,MISC:CMOS,ANALOG MUX;TRIPLE SPDT;CD4053, DIP16.3	02735	CD4053BF
A10VR301	152-0437-00		SEMICON DVC,DI:ZEN,SI,8.2V,2%,0.4W,DO-7	80009	152-0437-00
A10VR302	152-0437-00		SEMICON DVC,DI:ZEN,SI,8.2V,2%,0.4W,DO-7	80009	152-0437-00
A10VR303	152-0437-00		SEMICON DVC,DI:ZEN,SI,8.2V,2%,0.4W,DO-7	80009	152-0437-00
A10VR304	152-0437-00		SEMICON DVC,DI:ZEN,SI,8.2V,2%,0.4W,DO-7	80009	152-0437-00
A10VR308	152-0437-00		SEMICON DVC,DI:ZEN,SI,8.2V,2%,0.4W,DO-7	80009	152-0437-00
A10VR309	152-0166-00		SEMICON DVC,DI:ZEN,SI,6.2V,5%,400MW,DO-7	04713	SZ11738RL
A10VR310	152-0166-00		SEMICON DVC,DI:ZEN,SI,6.2V,5%,400MW,DO-7	04713	SZ11738RL
A10VR311	152-0168-00		SEMICON DVC,DI:ZEN,SI,12V,5%,0.4W,DO-763B	80009	152-0168-00
A10VR312	152-0168-00		SEMICON DVC,DI:ZEN,SI,12V,5%,0.4W,DO-763B	80009	152-0168-00
A10VR801	152-0055-00		SEMICON DVC,DI:ZEN,SI,11V,5%,0.4W,DO-7	14433	Z5407
A10VR2701	152-0306-00		SEMICON DVC,DI:ZEN,SI,9.1V,5%,0.4W,DO-7	80009	152-0306-00
A10W9	198-5523-00		WIRE SET,ELEC:SOCKET ASSY CRT	80009	198-5523-00
A10W17	196-3069-00		LEAD,ELECTRICAL:22 AWG,5.0 L,9-N	80009	196-3069-00
A10W18	196-3069-00		LEAD,ELECTRICAL:22 AWG,5.0 L,9-N	80009	196-3069-00
A10W19	196-3069-00		LEAD,ELECTRICAL:22 AWG,5.0 L,9-N	80009	196-3069-00
A10W20	196-3069-00		LEAD,ELECTRICAL:22 AWG,5.0 L,9-N	80009	196-3069-00
A10W100	131-0566-00		BUS,CONDUCTOR:DUMMY RES,0.094 OD X 0.225 L	24546	OMA 07
A10W101	131-0566-00		BUS,CONDUCTOR:DUMMY RES,0.094 OD X 0.225 L	24546	OMA 07
A10W102	131-0566-00		BUS,CONDUCTOR:DUMMY RES,0.094 OD X 0.225 L	24546	OMA 07
A10W200	131-0566-00		BUS,CONDUCTOR:DUMMY RES,0.094 OD X 0.225 L	24546	OMA 07
A10W201	131-0566-00		BUS,CONDUCTOR:DUMMY RES,0.094 OD X 0.225 L	24546	OMA 07
A10W202	131-0566-00		BUS,CONDUCTOR:DUMMY RES,0.094 OD X 0.225 L	24546	OMA 07
A10W203	131-0566-00		BUS,CONDUCTOR:DUMMY RES,0.094 OD X 0.225 L	24546	OMA 07
A10W205	131-0566-00		BUS,CONDUCTOR:DUMMY RES,0.094 OD X 0.225 L	24546	OMA 07
A10W206	131-0566-00		BUS,CONDUCTOR:DUMMY RES,0.094 OD X 0.225 L	24546	OMA 07
A10W207	131-0566-00		BUS,CONDUCTOR:DUMMY RES,0.094 OD X 0.225 L	24546	OMA 07
A10W208	131-0566-00		BUS,CONDUCTOR:DUMMY RES,0.094 OD X 0.225 L	24546	OMA 07
A10W209	131-0566-00		BUS,CONDUCTOR:DUMMY RES,0.094 OD X 0.225 L	24546	OMA 07
A10W210	131-0566-00		BUS,CONDUCTOR:DUMMY RES,0.094 OD X 0.225 L	24546	OMA 07
A10W223	131-0566-00		BUS,CONDUCTOR:DUMMY RES,0.094 OD X 0.225 L	24546	OMA 07
A10W231	131-0566-00		BUS,CONDUCTOR:DUMMY RES,0.094 OD X 0.225 L	24546	OMA 07
A10W232	131-0566-00		BUS,CONDUCTOR:DUMMY RES,0.094 OD X 0.225 L	24546	OMA 07
A10W235	131-0566-00		BUS,CONDUCTOR:DUMMY RES,0.094 OD X 0.225 L	24546	OMA 07
A10W304	131-0566-00		BUS,CONDUCTOR:DUMMY RES,0.094 OD X 0.225 L	24546	OMA 07
A10W305	131-0566-00		BUS,CONDUCTOR:DUMMY RES,0.094 OD X 0.225 L	24546	OMA 07
A10W401	131-0566-00		BUS,CONDUCTOR:DUMMY RES,0.094 OD X 0.225 L	24546	OMA 07

Component No.	Tektronix Part No.	Serial/Assembly No. Effective Discnt	Name & Description	Mfr. Code	Mfr. Part No.
A10W406	131-0566-00		BUS, CONDUCTOR: DUMMY RES, 0.094 OD X 0.225 L	24546	OMA 07
A10W413	131-0566-00		BUS, CONDUCTOR: DUMMY RES, 0.094 OD X 0.225 L	24546	OMA 07
A10W414	131-0566-00		BUS, CONDUCTOR: DUMMY RES, 0.094 OD X 0.225 L	24546	OMA 07
A10W415	174-0733-01		CA ASSY, SP, ELEC: 4, 26 AWG, 4.5 L, RIBBON	80009	174-0733-01
A10W416	174-0732-01		CA ASSY, SP, ELEC: 4, 26 AWG, 3.0 L, RIBBON	80009	174-0732-01
A10W501	131-0566-00		BUS, CONDUCTOR: DUMMY RES, 0.094 OD X 0.225 L	24546	OMA 07
A10W502	131-0566-00		BUS, CONDUCTOR: DUMMY RES, 0.094 OD X 0.225 L	24546	OMA 07
A10W503	131-0566-00		BUS, CONDUCTOR: DUMMY RES, 0.094 OD X 0.225 L	24546	OMA 07
A10W504	131-0566-00		BUS, CONDUCTOR: DUMMY RES, 0.094 OD X 0.225 L	24546	OMA 07
A10W505	131-0566-00		BUS, CONDUCTOR: DUMMY RES, 0.094 OD X 0.225 L	24546	OMA 07
A10W506	131-0566-00		BUS, CONDUCTOR: DUMMY RES, 0.094 OD X 0.225 L	24546	OMA 07
A10W507	131-0566-00		BUS, CONDUCTOR: DUMMY RES, 0.094 OD X 0.225 L	24546	OMA 07
A10W510	131-0566-00		BUS, CONDUCTOR: DUMMY RES, 0.094 OD X 0.225 L	24546	OMA 07
A10W601	174-1070-00		CA ASSY, SP, ELEC: 17, 26 AWG, 7.7 L	80009	174-1070-00
A10W603	131-0566-00		BUS, CONDUCTOR: DUMMY RES, 0.094 OD X 0.225 L	24546	OMA 07
A10W604	131-0566-00		BUS, CONDUCTOR: DUMMY RES, 0.094 OD X 0.225 L	24546	OMA 07
A10W605	131-0566-00		BUS, CONDUCTOR: DUMMY RES, 0.094 OD X 0.225 L	24546	OMA 07
A10W606	131-0566-00		BUS, CONDUCTOR: DUMMY RES, 0.094 OD X 0.225 L	24546	OMA 07
A10W607	131-0566-00		BUS, CONDUCTOR: DUMMY RES, 0.094 OD X 0.225 L	24546	OMA 07
A10W610	131-0566-00		BUS, CONDUCTOR: DUMMY RES, 0.094 OD X 0.225 L	24546	OMA 07
A10W611	131-0566-00		BUS, CONDUCTOR: DUMMY RES, 0.094 OD X 0.225 L	24546	OMA 07
A10W802	131-0566-00		BUS, CONDUCTOR: DUMMY RES, 0.094 OD X 0.225 L	24546	OMA 07
A10W805	131-0566-00		BUS, CONDUCTOR: DUMMY RES, 0.094 OD X 0.225 L	24546	OMA 07
A10W806	131-0566-00		BUS, CONDUCTOR: DUMMY RES, 0.094 OD X 0.225 L	24546	OMA 07
A10W807	131-0566-00		BUS, CONDUCTOR: DUMMY RES, 0.094 OD X 0.225 L	24546	OMA 07
A10W808	131-0566-00		BUS, CONDUCTOR: DUMMY RES, 0.094 OD X 0.225 L	24546	OMA 07
A10W810	131-0566-00		BUS, CONDUCTOR: DUMMY RES, 0.094 OD X 0.225 L	24546	OMA 07
A10W811	131-0566-00		BUS, CONDUCTOR: DUMMY RES, 0.094 OD X 0.225 L	24546	OMA 07
A10W815	131-0566-00		BUS, CONDUCTOR: DUMMY RES, 0.094 OD X 0.225 L	24546	OMA 07
A10W820	131-0566-00		BUS, CONDUCTOR: DUMMY RES, 0.094 OD X 0.225 L	24546	OMA 07
A10W821	131-0566-00		BUS, CONDUCTOR: DUMMY RES, 0.094 OD X 0.225 L	24546	OMA 07
A10W906	131-0566-00		BUS, CONDUCTOR: DUMMY RES, 0.094 OD X 0.225 L	24546	OMA 07
A10W1000	131-0566-00		BUS, CONDUCTOR: DUMMY RES, 0.094 OD X 0.225 L	24546	OMA 07
A10W1101	131-0566-00		BUS, CONDUCTOR: DUMMY RES, 0.094 OD X 0.225 L	24546	OMA 07
A10W1102	131-0566-00		BUS, CONDUCTOR: DUMMY RES, 0.094 OD X 0.225 L	24546	OMA 07
A10W1103	131-0566-00		BUS, CONDUCTOR: DUMMY RES, 0.094 OD X 0.225 L	24546	OMA 07
A10W1104	131-0566-00	B020546	BUS, CONDUCTOR: DUMMY RES, 0.094 OD X 0.225 L	24546	OMA 07
A10W1105	131-0566-00	B020546	BUS, CONDUCTOR: DUMMY RES, 0.094 OD X 0.225 L	24546	OMA 07
A10W1106	131-0566-00		BUS, CONDUCTOR: DUMMY RES, 0.094 OD X 0.225 L	24546	OMA 07
A10W1108	131-0566-00		BUS, CONDUCTOR: DUMMY RES, 0.094 OD X 0.225 L	24546	OMA 07
A10W1200	131-0566-00		BUS, CONDUCTOR: DUMMY RES, 0.094 OD X 0.225 L	24546	OMA 07
A10W1201	131-0566-00		BUS, CONDUCTOR: DUMMY RES, 0.094 OD X 0.225 L	24546	OMA 07
A10W1202	131-0566-00		BUS, CONDUCTOR: DUMMY RES, 0.094 OD X 0.225 L	24546	OMA 07
A10W1203	131-0566-00		BUS, CONDUCTOR: DUMMY RES, 0.094 OD X 0.225 L	24546	OMA 07
A10W1204	131-0566-00		BUS, CONDUCTOR: DUMMY RES, 0.094 OD X 0.225 L	24546	OMA 07
A10W1205	131-0566-00		BUS, CONDUCTOR: DUMMY RES, 0.094 OD X 0.225 L	24546	OMA 07
A10W1209	131-0566-00		BUS, CONDUCTOR: DUMMY RES, 0.094 OD X 0.225 L	24546	OMA 07
A10W1210	131-0566-00		BUS, CONDUCTOR: DUMMY RES, 0.094 OD X 0.225 L	24546	OMA 07
A10W1216	131-0566-00		BUS, CONDUCTOR: DUMMY RES, 0.094 OD X 0.225 L	24546	OMA 07
A10W1217	131-0566-00		BUS, CONDUCTOR: DUMMY RES, 0.094 OD X 0.225 L	24546	OMA 07
A10W1218	131-0566-00		BUS, CONDUCTOR: DUMMY RES, 0.094 OD X 0.225 L	24546	OMA 07
A10W1221	131-0566-00		BUS, CONDUCTOR: DUMMY RES, 0.094 OD X 0.225 L	24546	OMA 07
A10W1222	131-0566-00		BUS, CONDUCTOR: DUMMY RES, 0.094 OD X 0.225 L	24546	OMA 07
A10W1223	131-0566-00		BUS, CONDUCTOR: DUMMY RES, 0.094 OD X 0.225 L	24546	OMA 07
A10W1231	131-0566-00		BUS, CONDUCTOR: DUMMY RES, 0.094 OD X 0.225 L	24546	OMA 07
A10W1237	131-0566-00		BUS, CONDUCTOR: DUMMY RES, 0.094 OD X 0.225 L	24546	OMA 07
A10W1247	131-0566-00		BUS, CONDUCTOR: DUMMY RES, 0.094 OD X 0.225 L	24546	OMA 07

Replaceable Electrical Parts - 2247A Service

Component No.	Tektronix Part No.	Serial/Assembly No. Effective	Discnt	Name & Description	Mfr. Code	Mfr. Part No.
A10W1248	131-0566-00			BUS, CONDUCTOR: DUMMY RES, 0.094 OD X 0.225 L	24546	OMA 07
A10W1249	131-0566-00			BUS, CONDUCTOR: DUMMY RES, 0.094 OD X 0.225 L	24546	OMA 07
A10W1250	131-0566-00			BUS, CONDUCTOR: DUMMY RES, 0.094 OD X 0.225 L	24546	OMA 07
A10W1251	131-0566-00			BUS, CONDUCTOR: DUMMY RES, 0.094 OD X 0.225 L	24546	OMA 07
A10W1252	131-0566-00			BUS, CONDUCTOR: DUMMY RES, 0.094 OD X 0.225 L	24546	OMA 07
A10W1255	131-0566-00			BUS, CONDUCTOR: DUMMY RES, 0.094 OD X 0.225 L	24546	OMA 07
A10W1277	131-0566-00			BUS, CONDUCTOR: DUMMY RES, 0.094 OD X 0.225 L	24546	OMA 07
A10W1288	131-0566-00			BUS, CONDUCTOR: DUMMY RES, 0.094 OD X 0.225 L	24546	OMA 07
A10W2302	174-1041-00			CA ASSY, SP, ELEC: 18 COND, 8.5 L, RIBBON	80009	174-1041-00
A10W2304	174-1039-00			CA ASSY, SP, ELEC: 12 COND, 11.3 L, RIBBON	80009	174-1039-00
A10W2502	175-9903-00			CA ASSY, SP, ELEC: 25, 27 AWG, 6.0 L	80009	175-9903-00
A10W2701	131-0566-00			BUS, CONDUCTOR: DUMMY RES, 0.094 OD X 0.225 L	24546	OMA 07
A10XU421	136-1005-00	B010100	B010599	SKT, PL-IN ELEK: MICROCKT, 28 PIN	TK1650	3-821581-1
A10XU421	136-1065-00	B010600		SKT, PL-IN ELEK: MICROCKT, 28 PIN, LOW PROFILE	TK1650	641746-3
A10XU431	136-1005-00	B010100	B010599	SKT, PL-IN ELEK: MICROCKT, 28 PIN	TK1650	3-821581-1
A10XU431	136-1065-00	B010600		SKT, PL-IN ELEK: MICROCKT, 28 PIN, LOW PROFILE	TK1650	641746-3
A10Y600	119-2051-00			RESONATOR, CER: 10MHZ	80009	119-2051-00
A12	672-0262-00			CIRCUIT BD ASSY: FRONT PANEL MODULE	80009	672-0262-00
A12A12	670-9402-01			CIRCUIT BD ASSY: POTENTIOMETER	80009	670-9402-01
A12A12J2105	131-3626-00			CONN, RCPT, ELEC: SIP STRIP RCPT 17 POSITION	00779	643649-1
A12A12R2101	311-2343-00			RES, VAR, NONWW: CKT BD, 5K OHM, 20%, 0.5W	32997	91Z1AZ45EA0119
A12A12R2102	311-2345-00			RES, VAR, NONWW: CKT BD, 5K OHM, 20%, 0.5W	32997	91Z1AZ45EA0117
A12A12R2103	311-2343-00			RES, VAR, NONWW: CKT BD, 5K OHM, 20%, 0.5W	32997	91Z1AZ45EA0119
A12A12R2104	311-2345-00			RES, VAR, NONWW: CKT BD, 5K OHM, 20%, 0.5W	32997	91Z1AZ45EA0117
A12A12R2105	311-2345-00			RES, VAR, NONWW: CKT BD, 5K OHM, 20%, 0.5W	32997	91Z1AZ45EA0117
A12A12R2106	311-2345-00			RES, VAR, NONWW: CKT BD, 5K OHM, 20%, 0.5W	32997	91Z1AZ45EA0117
A12A12R2107	311-2343-00			RES, VAR, NONWW: CKT BD, 5K OHM, 20%, 0.5W	32997	91Z1AZ45EA0119
A12A12R2108	311-2345-00			RES, VAR, NONWW: CKT BD, 5K OHM, 20%, 0.5W	32997	91Z1AZ45EA0117
A12A12R2109	311-2345-00			RES, VAR, NONWW: CKT BD, 5K OHM, 20%, 0.5W	32997	91Z1AZ45EA0117
A12A12R2110	311-2345-00			RES, VAR, NONWW: CKT BD, 5K OHM, 20%, 0.5W	32997	91Z1AZ45EA0117
A12A12R2111	311-2181-00			RES, VAR, NONWW: LINEAR, 5K OHM, 30%, 0.25W	32997	91Z2D-Z45-EA0020
A12A12R2112	311-2345-00			RES, VAR, NONWW: CKT BD, 5K OHM, 20%, 0.5W	32997	91Z1AZ45EA0117
A12A12R2113	311-2181-00			RES, VAR, NONWW: LINEAR, 5K OHM, 30%, 0.25W	32997	91Z2D-Z45-EA0020
A12A14	670-9399-01			CIRCUIT BD ASSY: SWITCH	80009	670-9399-01
A12A14C2001	281-0909-00			CAP, FXD, CER DI: 0.022UF, 20%, 50V	54583	MA12X7R1H223M-T
A12A14CR2001	152-0141-02			SEMICON DVC, DI: SW, SI, 30V, 150MA, 30V, DO-35	03508	DA2527 (1N4152)
A12A14CR2002	152-0141-02			SEMICON DVC, DI: SW, SI, 30V, 150MA, 30V, DO-35	03508	DA2527 (1N4152)
A12A14CR2003	152-0141-02			SEMICON DVC, DI: SW, SI, 30V, 150MA, 30V, DO-35	03508	DA2527 (1N4152)
A12A14CR2004	152-0141-02			SEMICON DVC, DI: SW, SI, 30V, 150MA, 30V, DO-35	03508	DA2527 (1N4152)
A12A14CR2005	152-0141-02			SEMICON DVC, DI: SW, SI, 30V, 150MA, 30V, DO-35	03508	DA2527 (1N4152)
A12A14CR2006	152-0141-02			SEMICON DVC, DI: SW, SI, 30V, 150MA, 30V, DO-35	03508	DA2527 (1N4152)
A12A14DS2001	150-1160-00			LT EMITTING DIO: GREEN	50434	QLMP 1587
A12A14DS2002	150-1160-00			LT EMITTING DIO: GREEN	50434	QLMP 1587
A12A14DS2003	150-1160-00			LT EMITTING DIO: GREEN	50434	QLMP 1587
A12A14DS2004	150-1160-00			LT EMITTING DIO: GREEN	50434	QLMP 1587
A12A14DS2005	150-1160-00			LT EMITTING DIO: GREEN	50434	QLMP 1587
A12A14DS2006	150-1160-00			LT EMITTING DIO: GREEN	50434	QLMP 1587
A12A14DS2007	150-1160-00			LT EMITTING DIO: GREEN	50434	QLMP 1587
A12A14DS2008	150-1160-00			LT EMITTING DIO: GREEN	50434	QLMP 1587
A12A14DS2009	150-1160-00			LT EMITTING DIO: GREEN	50434	QLMP 1587
A12A14DS2010	150-1160-00			LT EMITTING DIO: GREEN	50434	QLMP 1587
A12A14DS2011	150-1160-00			LT EMITTING DIO: GREEN	50434	QLMP 1587
A12A14DS2012	150-1161-00			LT EMITTING DIO: YELLOW	50434	QLMP 1487

Component No.	Tektronix Part No.	Serial/Assembly No. Effective Dscnt	Name & Description	Mfr. Code	Mfr. Part No.
A12A14DS2013	150-1160-00		LT EMITTING DIO:GREEN	50434	QLMP 1587
A12A14DS2014	150-1160-00		LT EMITTING DIO:GREEN	50434	QLMP 1587
A12A14DS2015	150-1160-00		LT EMITTING DIO:GREEN	50434	QLMP 1587
A12A14DS2020	150-1160-00		LT EMITTING DIO:GREEN	50434	QLMP 1587
A12A14DS2021	150-1160-00		LT EMITTING DIO:GREEN	50434	QLMP 1587
A12A14DS2022	150-1161-00		LT EMITTING DIO:YELLOW	50434	QLMP 1487
A12A14DS2023	150-1161-00		LT EMITTING DIO:YELLOW	50434	QLMP 1487
A12A14DS2025	150-1160-00		LT EMITTING DIO:GREEN	50434	QLMP 1587
A12A14DS2026	150-1160-00		LT EMITTING DIO:GREEN	50434	QLMP 1587
A12A14DS2027	150-1160-00		LT EMITTING DIO:GREEN	50434	QLMP 1587
A12A14DS2028	150-1160-00		LT EMITTING DIO:GREEN	50434	QLMP 1587
A12A14DS2029	150-1160-00		LT EMITTING DIO:GREEN	50434	QLMP 1587
A12A14DS2030	150-1160-00		LT EMITTING DIO:GREEN	50434	QLMP 1587
A12A14DS2031	150-1160-00		LT EMITTING DIO:GREEN	50434	QLMP 1587
A12A14DS2032	150-1160-00		LT EMITTING DIO:GREEN	50434	QLMP 1587
A12A14DS2033	150-1160-00		LT EMITTING DIO:GREEN	50434	QLMP 1587
A12A14DS2034	150-1161-00		LT EMITTING DIO:YELLOW	50434	QLMP 1487
A12A14DS2035	150-1160-00		LT EMITTING DIO:GREEN	50434	QLMP 1587
A12A14DS2036	150-1160-00		LT EMITTING DIO:GREEN	50434	QLMP 1587
A12A14DS2037	150-1160-00		LT EMITTING DIO:GREEN	50434	QLMP 1587
A12A14DS2038	150-1160-00		LT EMITTING DIO:GREEN	50434	QLMP 1587
A12A14DS2039	150-1161-00		LT EMITTING DIO:YELLOW	50434	QLMP 1487
A12A14DS2041	150-1160-00		LT EMITTING DIO:GREEN	50434	QLMP 1587
A12A14DS2042	150-1160-00		LT EMITTING DIO:GREEN	50434	QLMP 1587
A12A14DS2043	150-1160-00		LT EMITTING DIO:GREEN	50434	QLMP 1587
A12A14DS2044	150-1161-00		LT EMITTING DIO:YELLOW	50434	QLMP 1487
A12A14DS2045	150-1161-00		LT EMITTING DIO:YELLOW	50434	QLMP 1487
A12A14DS2046	150-1161-00		LT EMITTING DIO:YELLOW	50434	QLMP 1487
A12A14DS2047	150-1160-00		LT EMITTING DIO:GREEN	50434	QLMP 1587
A12A14DS2048	150-1160-00		LT EMITTING DIO:GREEN	50434	QLMP 1587
A12A14R2001	307-0675-00		RES NTWK,FXD,FI:9,1K OHM,2%1.25W	11236	750-101-R1K OHM
A12A14R2002	307-0675-00		RES NTWK,FXD,FI:9,1K OHM,2%1.25W	11236	750-101-R1K OHM
A12A14U2001	156-0789-00		IC,DIGITAL:LSTTL,SHIFT REGISTER;8-BIT PISO; 74LS165,DIP16.3,TUBE	01295	SN74LS165N
A12A14U2002	156-0789-00		IC,DIGITAL:LSTTL,SHIFT REGISTER;8-BIT PISO; 74LS165,DIP16.3,TUBE	01295	SN74LS165N
A12A14W2501	175-9902-00		CA ASSY,SP,ELEC:20,27 AWG,8.05 L	80009	175-9902-00
A15	671-0247-00		CIRCUIT BD ASSY:DAC SUBSYS	80009	671-0247-00
A15C2601	281-0809-00		CAP,FXD,CER DI:200 PF,5%,100V	04222	MA101A201JAA
A15C2602	285-1300-01		CAP,FXD,MTLZD:0.1UF,10%,63V	55112	185/0.1/K/63/ABA
A15C2603	285-1300-01		CAP,FXD,MTLZD:0.1UF,10%,63V	55112	185/0.1/K/63/ABA
A15C2604	285-1300-01		CAP,FXD,MTLZD:0.1UF,10%,63V	55112	185/0.1/K/63/ABA
A15C2605	285-1300-01		CAP,FXD,MTLZD:0.1UF,10%,63V	55112	185/0.1/K/63/ABA
A15C2606	285-1300-01		CAP,FXD,MTLZD:0.1UF,10%,63V	55112	185/0.1/K/63/ABA
A15C2607	285-1300-01		CAP,FXD,MTLZD:0.1UF,10%,63V	55112	185/0.1/K/63/ABA
A15C2608	285-1300-01		CAP,FXD,MTLZD:0.1UF,10%,63V	55112	185/0.1/K/63/ABA
A15C2609	285-1300-01		CAP,FXD,MTLZD:0.1UF,10%,63V	55112	185/0.1/K/63/ABA
A15C2610	285-1300-01		CAP,FXD,MTLZD:0.1UF,10%,63V	55112	185/0.1/K/63/ABA
A15C2611	285-1300-01		CAP,FXD,MTLZD:0.1UF,10%,63V	55112	185/0.1/K/63/ABA
A15C2612	285-1300-01		CAP,FXD,MTLZD:0.1UF,10%,63V	55112	185/0.1/K/63/ABA
A15C2613	285-1300-01		CAP,FXD,MTLZD:0.1UF,10%,63V	55112	185/0.1/K/63/ABA
A15C2614	281-0909-00		CAP,FXD,CER DI:0.022UF,20%,50V	54583	MA12X7R1H223M-T
A15C2615	281-0909-00		CAP,FXD,CER DI:0.022UF,20%,50V	54583	MA12X7R1H223M-T
A15C2616	281-0909-00		CAP,FXD,CER DI:0.022UF,20%,50V	54583	MA12X7R1H223M-T
A15C2617	281-0909-00		CAP,FXD,CER DI:0.022UF,20%,50V	54583	MA12X7R1H223M-T

Replaceable Electrical Parts - 2247A Service

Component No.	Tektronix Part No.	Serial/Assembly No. Effective	Discort	Name & Description	Mfr. Code	Mfr. Part No.
A15C2618	281-0909-00			CAP,FXD,CER DI:0.022UF,20%,50V	54583	MA12X7R1H223M-T
A15C2619	281-0909-00			CAP,FXD,CER DI:0.022UF,20%,50V	54583	MA12X7R1H223M-T
A15C2620	281-0909-00			CAP,FXD,CER DI:0.022UF,20%,50V	54583	MA12X7R1H223M-T
A15C2630	283-0177-05			CAP,FXD,CER DI:1UF,+80-20%,25V	04222	SR305E105ZAATR
A15J2604	136-0948-00			SKT,PL-IN ELEK:12 POS,SIP,LOW PROFILE	80009	136-0948-00
A15R2601	322-3260-00			RES,FXD,FILM:4.99K OHM,1%,0.2W,TC=TO	57668	CRB20 FXE 4K99
A15R2602	313-1472-00			RES,FXD,FILM:4.7K OHM,5%,0.2W	57668	TR20JE 04K7
A15R2603	322-3231-00			RES,FXD,FILM:2.49K OHM,1%,0.2W,TC=TO	57668	CRB20 FXE 2K49
A15R2604	313-1101-00			RES,FXD,FILM:100 OHM,5%,0.2W	57668	TR20JE100E
A15R2606	307-0675-00			RES NTWK,FXD,FI:9,1K OHM,2%1.25W	11236	750-101-RIK OHM
A15R2607	307-0675-00			RES NTWK,FXD,FI:9,1K OHM,2%1.25W	11236	750-101-RIK OHM
A15R2608	313-1102-00			RES,FXD,FILM:1K OHM,5%,0.2W	57668	TR20JE01K0
A15R2609	313-1102-00			RES,FXD,FILM:1K OHM,5%,0.2W	57668	TR20JE01K0
A15R2610	313-1102-00			RES,FXD,FILM:1K OHM,5%,0.2W	57668	TR20JE01K0
A15R2611	313-1102-00			RES,FXD,FILM:1K OHM,5%,0.2W	57668	TR20JE01K0
A15R2612	313-1102-00			RES,FXD,FILM:1K OHM,5%,0.2W	57668	TR20JE01K0
A15R2613	313-1102-00			RES,FXD,FILM:1K OHM,5%,0.2W	57668	TR20JE01K0
A15R2614	313-1102-00			RES,FXD,FILM:1K OHM,5%,0.2W	57668	TR20JE01K0
A15R2615	313-1102-00			RES,FXD,FILM:1K OHM,5%,0.2W	57668	TR20JE01K0
A15R2616	313-1184-00			RES,FXD,FILM:180K OHM,5%,0.2W	57668	TR20JE180K
A15R2617	313-1184-00			RES,FXD,FILM:180K OHM,5%,0.2W	57668	TR20JE180K
A15R2618	313-1184-00			RES,FXD,FILM:180K OHM,5%,0.2W	57668	TR20JE180K
A15R2619	313-1184-00			RES,FXD,FILM:180K OHM,5%,0.2W	57668	TR20JE180K
A15R2620	313-1393-00			RES,FXD,FILM:39K OHM,5%,0.2W	57668	TR20JE 39K
A15U2601	160-5054-00			MICROCKT,DGTL:8-BIT MICROCOMPUTER	80009	160-5054-00
A15U2602	156-1589-00			MICROCKT,LINEAR:D/A CONVERTER,12 BIT,HIGH S PEED,MONOLITHIC	06665	DAC312FR
A15U2603	156-0382-00			IC,DIGITAL:LS TTL GATES;QUAD 2-INPUT NAND;74 LS00,DIP14.3,TUBE	01295	SN74LS00(N OR J)
A15U2604	156-0513-00			IC,MISC:CMOS,ANALOG MUX;8 CHANNEL;CD4051,DI P16.3	04713	MC14051BCL
A15U2605	156-0513-00			IC,MISC:CMOS,ANALOG MUX;8 CHANNEL;CD4051,DI P16.3	04713	MC14051BCL
A15U2606	156-1200-00			MICROCKT,LINEAR:BIFET,QUAD OPNL AMPL	01295	TL074CN
A15U2607	156-1200-00			MICROCKT,LINEAR:BIFET,QUAD OPNL AMPL	01295	TL074CN
A15U2608	156-1200-00			MICROCKT,LINEAR:BIFET,QUAD OPNL AMPL	01295	TL074CN
A15U2609	156-1191-00			MICROCKT,LINEAR:BIFET,DUAL OPNL AMPL	01295	TL072CP
A15W2601	174-1042-00			CA ASSY,SP,ELEC:25 COND,1.6 L,RIBBON	80009	174-1042-00
A15XU2601	136-0755-00			SKT,PL-IN ELEK:MICROCIRCUIT,28 DIP	09922	D1LB28P-108
A16	671-0812-00	B010100	B010515	CIRCUIT BD ASSY:PROCESSOR	80009	671-0812-00
A16	671-0812-01	B010516		CIRCUIT BD ASSY:PROCESSOR (DOES NOT INCLUDE U2519)	80009	671-0812-01
A16	672-0247-00	B010100	B010515	CIRCUIT BD ASSY:PROCESSOR	80009	672-0247-00
A16	672-0247-01	B010516		CIRCUIT BD ASSY:PROCESSOR (INCLUDES U2519)	80009	672-0247-01
A16BT2501	146-0055-00			BATTERY,DRY:3.0V,1200 MAH,LITHIUM	TK0510	BR-2/3A-E2P
A16C1901	281-0798-00	B010100	B010515	CAP,FXD,CER DI:51PF,1%,100V	04222	MA101A510GAA
A16C1902	281-0765-00	B010100	B010555	CAP,FXD,CER DI:100PF,5%,100V	04222	MA101A101JAA
A16C1902	281-0816-00	B010556		CAP,FXD,CER DI:82 PF,5%,100V	04222	MA106A820JAA
A16C1903	281-0909-00			CAP,FXD,CER DI:0.022UF,20%,50V	54583	MA12X7R1H223M-T
A16C1904	281-0158-00			CAP,VAR,CER DI:7-45PF,100WVDC SUBMIN CER DI SC TOP ADJ	59660	518-006 G 7-45
A16C1905	281-0909-00			CAP,FXD,CER DI:0.022UF,20%,50V	54583	MA12X7R1H223M-T
A16C1906	281-0909-00			CAP,FXD,CER DI:0.022UF,20%,50V	54583	MA12X7R1H223M-T
A16C1907	281-0909-00			CAP,FXD,CER DI:0.022UF,20%,50V	54583	MA12X7R1H223M-T
A16C1908	281-0909-00			CAP,FXD,CER DI:0.022UF,20%,50V	54583	MA12X7R1H223M-T

Component No.	Tektronix Part No.	Serial/Assembly No. Effective	Dscont	Name & Description	Mfr. Code	Mfr. Part No.
A16C1909	281-0775-01			CAP,FXD,CER DI:0.1UF,20%,50V	04222	SA105E104MAA
A16C1910	281-0812-00			CAP,FXD,CER DI:1000PF,10%,100V	04222	MA101C102KAA
A16C1911	281-0812-00			CAP,FXD,CER DI:1000PF,10%,100V	04222	MA101C102KAA
A16C1912	281-0763-00			CAP,FXD,CER DI:47PF,10%,100V	04222	MA101A470KAA
A16C1913	281-0819-00			CAP,FXD,CER DI:33 PF,5%,50V	04222	GC105A330J
A16C1914	281-0763-00			CAP,FXD,CER DI:47PF,10%,100V	04222	MA101A470KAA
A16C1915	281-0909-00			CAP,FXD,CER DI:0.022UF,20%,50V	54583	MA12X7R1H223M-T
A16C1916	281-0909-00			CAP,FXD,CER DI:0.022UF,20%,50V	54583	MA12X7R1H223M-T
A16C1917	281-0909-00			CAP,FXD,CER DI:0.022UF,20%,50V	54583	MA12X7R1H223M-T
A16C1920	281-0909-00			CAP,FXD,CER DI:0.022UF,20%,50V	54583	MA12X7R1H223M-T
A16C2300	281-0759-00			CAP,FXD,CER DI:22PF,10%,100V	04222	MA101A220KAA
A16C2301	285-1300-01			CAP,FXD,MTLZD:0.1UF,10%,63V	55112	185/0.1/K/63/ABA
A16C2302	285-1300-01			CAP,FXD,MTLZD:0.1UF,10%,63V	55112	185/0.1/K/63/ABA
A16C2303	285-1300-01			CAP,FXD,MTLZD:0.1UF,10%,63V	55112	185/0.1/K/63/ABA
A16C2304	281-0909-00			CAP,FXD,CER DI:0.022UF,20%,50V	54583	MA12X7R1H223M-T
A16C2305	285-1300-01			CAP,FXD,MTLZD:0.1UF,10%,63V	55112	185/0.1/K/63/ABA
A16C2306	285-1300-01			CAP,FXD,MTLZD:0.1UF,10%,63V	55112	185/0.1/K/63/ABA
A16C2307	285-1301-01			CAP,FXD,MTLZD:0.47UF,10%,50V	55112	1850.47K50ABB
A16C2308	285-1348-00			CAP,FXD,MTLZD:0.22UF,10%,63V	TK1573	ORDER BY DESCR
A16C2309	285-1301-01			CAP,FXD,MTLZD:0.47UF,10%,50V	55112	1850.47K50ABB
A16C2310	285-1348-00			CAP,FXD,MTLZD:0.22UF,10%,63V	TK1573	ORDER BY DESCR
A16C2311	281-0909-00			CAP,FXD,CER DI:0.022UF,20%,50V	54583	MA12X7R1H223M-T
A16C2312	281-0909-00			CAP,FXD,CER DI:0.022UF,20%,50V	54583	MA12X7R1H223M-T
A16C2313	281-0909-00			CAP,FXD,CER DI:0.022UF,20%,50V	54583	MA12X7R1H223M-T
A16C2314	281-0775-01			CAP,FXD,CER DI:0.1UF,20%,50V	04222	SA105E104MAA
A16C2315	281-0775-01			CAP,FXD,CER DI:0.1UF,20%,50V	04222	SA105E104MAA
A16C2316	281-0909-00			CAP,FXD,CER DI:0.022UF,20%,50V	54583	MA12X7R1H223M-T
A16C2317	281-0909-00			CAP,FXD,CER DI:0.022UF,20%,50V	54583	MA12X7R1H223M-T
A16C2318	281-0809-00			CAP,FXD,CER DI:200 PF,5%,100V	04222	MA101A201JAA
A16C2319	281-0909-00			CAP,FXD,CER DI:0.022UF,20%,50V	54583	MA12X7R1H223M-T
A16C2320	281-0798-00	B010100	B010614	CAP,FXD,CER DI:51PF,1%,100V	04222	MA101A510GAA
A16C2320	281-0763-00	B010615		CAP,FXD,CER DI:47PF,10%,100V	04222	MA101A470KAA
A16C2321	281-0909-00			CAP,FXD,CER DI:0.022UF,20%,50V	54583	MA12X7R1H223M-T
A16C2322	281-0798-00	B010100	B010614	CAP,FXD,CER DI:51PF,1%,100V	04222	MA101A510GAA
A16C2322	281-0763-00	B010615		CAP,FXD,CER DI:47PF,10%,100V	04222	MA101A470KAA
A16C2323	281-0798-00	B010100	B010614	CAP,FXD,CER DI:51PF,1%,100V	04222	MA101A510GAA
A16C2323	281-0763-00	B010615		CAP,FXD,CER DI:47PF,10%,100V	04222	MA101A470KAA
A16C2324	285-1300-01			CAP,FXD,MTLZD:0.1UF,10%,63V	55112	185/0.1/K/63/ABA
A16C2401	281-0909-00			CAP,FXD,CER DI:0.022UF,20%,50V	54583	MA12X7R1H223M-T
A16C2402	281-0909-00			CAP,FXD,CER DI:0.022UF,20%,50V	54583	MA12X7R1H223M-T
A16C2403	281-0909-00			CAP,FXD,CER DI:0.022UF,20%,50V	54583	MA12X7R1H223M-T
A16C2404	281-0909-00			CAP,FXD,CER DI:0.022UF,20%,50V	54583	MA12X7R1H223M-T
A16C2405	281-0909-00			CAP,FXD,CER DI:0.022UF,20%,50V	54583	MA12X7R1H223M-T
A16C2406	281-0909-00			CAP,FXD,CER DI:0.022UF,20%,50V	54583	MA12X7R1H223M-T
A16C2407	281-0909-00			CAP,FXD,CER DI:0.022UF,20%,50V	54583	MA12X7R1H223M-T
A16C2408	281-0909-00			CAP,FXD,CER DI:0.022UF,20%,50V	54583	MA12X7R1H223M-T
A16C2409	281-0909-00			CAP,FXD,CER DI:0.022UF,20%,50V	54583	MA12X7R1H223M-T
A16C2410	281-0909-00			CAP,FXD,CER DI:0.022UF,20%,50V	54583	MA12X7R1H223M-T
A16C2411	281-0809-00			CAP,FXD,CER DI:200 PF,5%,100V	04222	MA101A201JAA
A16C2412	281-0809-00			CAP,FXD,CER DI:200 PF,5%,100V	04222	MA101A201JAA
A16C2415	281-0775-01			CAP,FXD,CER DI:0.1UF,20%,50V	04222	SA105E104MAA
A16C2416	281-0798-00	B010100	B010614	CAP,FXD,CER DI:51PF,1%,100V	04222	MA101A510GAA
A16C2416	281-0763-00	B010615		CAP,FXD,CER DI:47PF,10%,100V	04222	MA101A470KAA
A16C2417	281-0798-00	B010100	B010614	CAP,FXD,CER DI:51PF,1%,100V	04222	MA101A510GAA
A16C2417	281-0763-00	B010615		CAP,FXD,CER DI:47PF,10%,100V	04222	MA101A470KAA
A16C2418	281-0798-00	B010100	B010614	CAP,FXD,CER DI:51PF,1%,100V	04222	MA101A510GAA
A16C2418	281-0763-00	B010615		CAP,FXD,CER DI:47PF,10%,100V	04222	MA101A470KAA
A16C2419	281-0798-00	B010100	B010614	CAP,FXD,CER DI:51PF,1%,100V	04222	MA101A510GAA

Replaceable Electrical Parts - 2247A Service

Component No.	Tektronix Part No.	Serial/Assembly No. Effective	Discont	Name & Description	Mfr. Code	Mfr. Part No.
A16C2419	281-0763-00	B010615		CAP, FXD, CER DI: 47PF, 10%, 100V	04222	MA101A470KAA
A16C2420	281-0798-00	B010100	B010614	CAP, FXD, CER DI: 51PF, 1%, 100V	04222	MA101A510GAA
A16C2420	281-0763-00	B010615		CAP, FXD, CER DI: 47PF, 10%, 100V	04222	MA101A470KAA
A16C2501	281-0909-00			CAP, FXD, CER DI: 0.022UF, 20%, 50V	54583	MA12X7R1H223M-T
A16C2502	281-0909-00			CAP, FXD, CER DI: 0.022UF, 20%, 50V	54583	MA12X7R1H223M-T
A16C2503	281-0909-00			CAP, FXD, CER DI: 0.022UF, 20%, 50V	54583	MA12X7R1H223M-T
A16C2504	281-0909-00			CAP, FXD, CER DI: 0.022UF, 20%, 50V	54583	MA12X7R1H223M-T
A16C2505	281-0909-00			CAP, FXD, CER DI: 0.022UF, 20%, 50V	54583	MA12X7R1H223M-T
A16C2506	281-0909-00			CAP, FXD, CER DI: 0.022UF, 20%, 50V	54583	MA12X7R1H223M-T
A16C2507	281-0909-00			CAP, FXD, CER DI: 0.022UF, 20%, 50V	54583	MA12X7R1H223M-T
A16C2508	281-0909-00			CAP, FXD, CER DI: 0.022UF, 20%, 50V	54583	MA12X7R1H223M-T
A16C2509	281-0909-00			CAP, FXD, CER DI: 0.022UF, 20%, 50V	54583	MA12X7R1H223M-T
A16C2510	281-0909-00			CAP, FXD, CER DI: 0.022UF, 20%, 50V	54583	MA12X7R1H223M-T
A16C2511	281-0909-00			CAP, FXD, CER DI: 0.022UF, 20%, 50V	54583	MA12X7R1H223M-T
A16C2514	281-0759-00			CAP, FXD, CER DI: 22PF, 10%, 100V	04222	MA101A220KAA
A16C2515	281-0759-00			CAP, FXD, CER DI: 22PF, 10%, 100V	04222	MA101A220KAA
A16C2516	285-1301-01			CAP, FXD, MTLZD: 0.47UF, 10%, 50V	55112	1850.47K50ABB
A16C2517	281-0775-01			CAP, FXD, CER DI: 0.1UF, 20%, 50V	04222	SA105E104MAA
A16C2518	285-1301-01			CAP, FXD, MTLZD: 0.47UF, 10%, 50V	55112	1850.47K50ABB
A16C2521	281-0772-00			CAP, FXD, CER DI: 4700PF, 10%, 100V	04222	MA201C472KAA
A16C2522	281-0772-00			CAP, FXD, CER DI: 4700PF, 10%, 100V	04222	MA201C472KAA
A16C2523	281-0772-00			CAP, FXD, CER DI: 4700PF, 10%, 100V	04222	MA201C472KAA
A16C2524	281-0772-00			CAP, FXD, CER DI: 4700PF, 10%, 100V	04222	MA201C472KAA
A16C2525	281-0772-00			CAP, FXD, CER DI: 4700PF, 10%, 100V	04222	MA201C472KAA
A16C2526	281-0772-00			CAP, FXD, CER DI: 4700PF, 10%, 100V	04222	MA201C472KAA
A16C2530	281-0909-00			CAP, FXD, CER DI: 0.022UF, 20%, 50V	54583	MA12X7R1H223M-T
A16C2531	281-0909-00			CAP, FXD, CER DI: 0.022UF, 20%, 50V	54583	MA12X7R1H223M-T
A16C2532	281-0909-00			CAP, FXD, CER DI: 0.022UF, 20%, 50V	54583	MA12X7R1H223M-T
A16C2541	290-0748-00			CAP, FXD, ELCTLT: 10UF, +50-20%, 25WVDC	54473	ECE-B1EV100S
A16C2543	281-0772-00			CAP, FXD, CER DI: 4700PF, 10%, 100V	04222	MA201C472KAA
A16C2544	281-0772-00			CAP, FXD, CER DI: 4700PF, 10%, 100V	04222	MA201C472KAA
A16C2545	281-0772-00			CAP, FXD, CER DI: 4700PF, 10%, 100V	04222	MA201C472KAA
A16C2546	281-0772-00			CAP, FXD, CER DI: 4700PF, 10%, 100V	04222	MA201C472KAA
A16C2547	281-0772-00			CAP, FXD, CER DI: 4700PF, 10%, 100V	04222	MA201C472KAA
A16C2548	281-0772-00			CAP, FXD, CER DI: 4700PF, 10%, 100V	04222	MA201C472KAA
A16C2549	281-0772-00			CAP, FXD, CER DI: 4700PF, 10%, 100V	04222	MA201C472KAA
A16C2550	281-0772-00			CAP, FXD, CER DI: 4700PF, 10%, 100V	04222	MA201C472KAA
A16C2551	281-0798-00	B010100	B010614	CAP, FXD, CER DI: 51PF, 1%, 100V	04222	MA101A510GAA
A16C2551	281-0763-00	B010615		CAP, FXD, CER DI: 47PF, 10%, 100V	04222	MA101A470KAA
A16C2552	281-0798-00	B010100	B010614	CAP, FXD, CER DI: 51PF, 1%, 100V	04222	MA101A510GAA
A16C2552	281-0763-00	B010615		CAP, FXD, CER DI: 47PF, 10%, 100V	04222	MA101A470KAA
A16C2553	281-0798-00	B010100	B010614	CAP, FXD, CER DI: 51PF, 1%, 100V	04222	MA101A510GAA
A16C2553	281-0763-00	B010615		CAP, FXD, CER DI: 47PF, 10%, 100V	04222	MA101A470KAA
A16C2554	281-0798-00	B010100	B010614	CAP, FXD, CER DI: 51PF, 1%, 100V	04222	MA101A510GAA
A16C2554	281-0763-00	B010615		CAP, FXD, CER DI: 47PF, 10%, 100V	04222	MA101A470KAA
A16C2555	281-0798-00	B010100	B010614	CAP, FXD, CER DI: 51PF, 1%, 100V	04222	MA101A510GAA
A16C2555	281-0763-00	B010615		CAP, FXD, CER DI: 47PF, 10%, 100V	04222	MA101A470KAA
A16CR1901	152-0141-02			SEMICON DVC, DI: SW, SI, 30V, 150MA, 30V, DO-35	03508	DA2527 (1N4152)
A16CR1902	152-0141-02			SEMICON DVC, DI: SW, SI, 30V, 150MA, 30V, DO-35	03508	DA2527 (1N4152)
A16CR1903	152-0269-00			SEMICON DVC, DI: VVC, SI, 35V, 33PF AT 4V, DO-7	04713	SMV1263
A16CR1904	152-0141-02			SEMICON DVC, DI: SW, SI, 30V, 150MA, 30V, DO-35	03508	DA2527 (1N4152)
A16CR1905	152-0141-02			SEMICON DVC, DI: SW, SI, 30V, 150MA, 30V, DO-35	03508	DA2527 (1N4152)
A16CR2501	152-0141-02			SEMICON DVC, DI: SW, SI, 30V, 150MA, 30V, DO-35	03508	DA2527 (1N4152)
A16CR2502	152-0951-00			DIODE, SIG: SCHKY, ; 60V, 2.25PF; 1N6263(HSCH1001), DO-35, TR	80009	152-0951-00
A16CR2504	152-0141-02			SEMICON DVC, DI: SW, SI, 30V, 150MA, 30V, DO-35	03508	DA2527 (1N4152)
A16CR2505	152-0951-00			DIODE, SIG: SCHKY, ; 60V, 2.25PF; 1N6263(HSCH1001), DO-35, TR	80009	152-0951-00

Component No.	Tektronix		Serial/Assembly No.		Name & Description	Mfr. Code	Mfr. Part No.
	Part No.	Effective	Discont				
A16DS2501	150-1161-00				LT EMITTING DIO:YELLOW	50434	QLMP 1487
A16J1901	131-3626-00				CONN,RCPT,ELEC:SIP STRIP RCPT 17 POSITION	00779	643649-1
A16J1902	131-2921-00				CONN,RCPT,ELEC:HEADER,1 X 2,0.1 SPACING	00779	1-86479-3
A16J1905	136-0813-00				SKT,PL-IN ELEK:CHIP CARRIER,68 CONTACTS	19613	268-5400-00-1102
A16J2302	136-0949-00				SKT,PL-IN ELEK:18 POS,SIP,LOW PROFILE	80009	136-0949-00
A16J2304	136-0948-00				SKT,PL-IN ELEK:12 POS,SIP,LOW PROFILE	80009	136-0948-00
A16J2501	131-3624-00				CONN,RCPT,ELEC:SIP STRIP RCPT 20 POSITION	00779	643652-1
A16J2502	131-3623-00				CONN,RCPT,ELEC:SIP STRIP RCPT 25 POSITION	00779	643657-1
A16J2503	131-4529-00				CONN,RCPT,ELEC:HEADER,10 PIN	80009	131-4529-00
A16J2601	131-3623-00				CONN,RCPT,ELEC:SIP STRIP RCPT 25 POSITION	00779	643657-1
A16L1901	108-0606-00				COIL,RF:FIXED,31NH	80009	108-0606-00
A16Q1901	151-0190-00				TRANSISTOR:NPN,SI,TO-92	80009	151-0190-00
A16Q1902	151-0190-00	B010100	B010515		TRANSISTOR:NPN,SI,TO-92	80009	151-0190-00
A16Q1903	151-0369-00				TRANSISTOR:PNP,SI,X-55	80009	151-0369-00
A16Q2501	151-0716-01				TRANSISTOR:NPN,SI,PWR DARLINGTON,1W,TO-92 PLUS	80009	151-0716-01
A16Q2502	151-0716-01				TRANSISTOR:NPN,SI,PWR DARLINGTON,1W,TO-92 PLUS	80009	151-0716-01
A16Q2503	151-0716-01				TRANSISTOR:NPN,SI,PWR DARLINGTON,1W,TO-92 PLUS	80009	151-0716-01
A16Q2504	151-0716-01				TRANSISTOR:NPN,SI,PWR DARLINGTON,1W,TO-92 PLUS	80009	151-0716-01
A16Q2505	151-0716-01				TRANSISTOR:NPN,SI,PWR DARLINGTON,1W,TO-92 PLUS	80009	151-0716-01
A16Q2506	151-0716-01				TRANSISTOR:NPN,SI,PWR DARLINGTON,1W,TO-92 PLUS	80009	151-0716-01
A16Q2507	151-0190-00				TRANSISTOR:NPN,SI,TO-92	80009	151-0190-00
A16R1901	313-1333-00	B010100	B010515		RES,FXD,FILM:33K OHM,5%,0.2W	57668	TR20JE 33K
A16R1901	313-1473-00	B010516			RES,FXD,FILM:47K OHM,5%,0.2W	57668	TR20JE 47K
A16R1902	313-1123-00	B010100	B010515		RES,FXD,FILM:12K OHM,5%,0.2W	57668	TR20JE12K0
A16R1902	313-1682-00	B010516			RES,FXD,FILM:6.8K OHM,5%,0.2W	57668	TR20JE 06K8
A16R1903	313-1332-00				RES,FXD,FILM:3.3K OHM,5%,0.2W	57668	TR20JE 03K3
A16R1904	313-1102-00				RES,FXD,FILM:1K OHM,5%,0.2W	57668	TR20JE01K0
A16R1905	313-1511-00	B010100	B010515		RES,FXD,FILM:510 OHM,5%,0.2W	57668	TR20JT68 510E
A16R1905	313-1102-00	B010516			RES,FXD,FILM:1K OHM,5%,0.2W	57668	TR20JE01K0
A16R1906	313-1102-00				RES,FXD,FILM:1K OHM,5%,0.2W	57668	TR20JE01K0
A16R1907	313-1912-00				RES,FXD,FILM:9.1K OHM,5%,0.2W	57668	TR20 FXE 9.1K
A16R1908	313-1302-00				RES,FXD,FILM:3K OHM,5%,0.2W	57668	TR20JE 03K0
A16R1909	313-1121-00				RES,FXD,FILM:120 OHM,5%,0.2W	80009	313-1121-00
A16R1910	313-1102-00				RES,FXD,FILM:1K OHM,5%,0.2W	57668	TR20JE01K0
A16R1911	313-1821-00				RES,FXD,FILM:820 OHM,5%,0.2W	57668	TR20JE 820E
A16R1912	313-1821-00				RES,FXD,FILM:820 OHM,5%,0.2W	57668	TR20JE 820E
A16R1913	313-1821-00				RES,FXD,FILM:820 OHM,5%,0.2W	57668	TR20JE 820E
A16R1914	313-1821-00				RES,FXD,FILM:820 OHM,5%,0.2W	57668	TR20JE 820E
A16R1915	313-1821-00				RES,FXD,FILM:820 OHM,5%,0.2W	57668	TR20JE 820E
A16R1916	313-1821-00				RES,FXD,FILM:820 OHM,5%,0.2W	57668	TR20JE 820E
A16R1917	307-1175-00				RES NTWK,FXD,FI:2.2K OHM,2%	91637	CSC10A01-222G
A16R1918	307-0539-00				RES NTWK,FXD,FI:(7)510 OHM,10%,1W	11236	750-81-R510 OHM
A16R1919	313-1331-00				RES,FXD,FILM:330 OHM,5%,0.2W	57668	TR20JE 330E
A16R1920	313-1331-00				RES,FXD,FILM:330 OHM,5%,0.2W	57668	TR20JE 330E
A16R1921	313-1331-00				RES,FXD,FILM:330 OHM,5%,0.2W	57668	TR20JE 330E
A16R1922	313-1331-00				RES,FXD,FILM:330 OHM,5%,0.2W	57668	TR20JE 330E
A16R1923	313-1331-00				RES,FXD,FILM:330 OHM,5%,0.2W	57668	TR20JE 330E
A16R1924	313-1331-00				RES,FXD,FILM:330 OHM,5%,0.2W	57668	TR20JE 330E
A16R1925	313-1331-00				RES,FXD,FILM:330 OHM,5%,0.2W	57668	TR20JE 330E
A16R1926	313-1331-00				RES,FXD,FILM:330 OHM,5%,0.2W	57668	TR20JE 330E
A16R1927	307-1175-00				RES NTWK,FXD,FI:2.2K OHM,2%	91637	CSC10A01-222G
A16R1928	322-3260-00				RES,FXD,FILM:4.99K OHM,1%,0.2W,TC=TO	57668	CRB20 FXE 4K99

Replaceable Electrical Parts - 2247A Service

Component No.	Tektronix Part No.	Serial/Assembly No. Effective Dscnt	Name & Description	Mfr. Code	Mfr. Part No.
A16R1929	322-3260-00		RES,FXD,FILM:4.99K OHM,1%,0.2W,TC=TO	57668	CRB20 FXE 4K99
A16R1930	313-1222-00		RES,FXD,FILM:2.2K OHM,5%,0.2W	57668	TR20JE 02K2
A16R1931	313-1183-00		RES,FXD,FILM:18K OHM,5%,0.2W	57668	TR20JT68 18K
A16R1932	313-1222-00		RES,FXD,FILM:2.2K OHM,5%,0.2W	57668	TR20JE 02K2
A16R1933	313-1683-00		RES,FXD,FILM:68K OHM,5%,0.2W	57668	TR20JE 68K
A16R1934	313-1221-00		RES,FXD,FILM:220 OHM,5%,0.2W	57668	TR20JE220E
A16R1935	313-1333-00		RES,FXD,FILM:33K OHM,5%,0.2W	57668	TR20JE 33K
A16R1936	313-1103-00		RES,FXD,FILM:10K OHM,5%,0.2W	57668	TR20JE10K0
A16R1937	313-1621-00		RES,FXD,FILM:620 OHM,5%,0.2W	57668	TR20JE 620E
A16R1938	313-1431-00		RES,FXD,FILM:430 OHM,5%,0.2W	57668	TR20JE 430E
A16R1939	313-1112-00		RES,FXD,FILM:1.1K,5%,0.2W	80009	313-1112-00
A16R1940	313-1362-00		RES,FXD,FILM:3.6K OHM,5%,0.2W	57668	TR20JE 03K6
A16R1941	313-1511-00		RES,FXD,FILM:510 OHM,5%,0.2W	57668	TR20JT68 510E
A16R1942	313-1511-00		RES,FXD,FILM:510 OHM,5%,0.2W	57668	TR20JT68 510E
A16R1943	313-1121-00		RES,FXD,FILM:120 OHM,5%,0.2W	80009	313-1121-00
A16R1944	313-1121-00		RES,FXD,FILM:120 OHM,5%,0.2W	80009	313-1121-00
A16R1945	313-1121-00		RES,FXD,FILM:120 OHM,5%,0.2W	80009	313-1121-00
A16R1946	313-1121-00		RES,FXD,FILM:120 OHM,5%,0.2W	80009	313-1121-00
A16R1947	313-1221-00		RES,FXD,FILM:220 OHM,5%,0.2W	57668	TR20JE220E
A16R1948	313-1221-00		RES,FXD,FILM:220 OHM,5%,0.2W	57668	TR20JE220E
A16R1949	313-1121-00		RES,FXD,FILM:120 OHM,5%,0.2W	80009	313-1121-00
A16R1950	313-1121-00		RES,FXD,FILM:120 OHM,5%,0.2W	80009	313-1121-00
A16R1951	313-1221-00		RES,FXD,FILM:220 OHM,5%,0.2W	57668	TR20JE220E
A16R1952	313-1221-00		RES,FXD,FILM:220 OHM,5%,0.2W	57668	TR20JE220E
A16R2301	322-3260-00		RES,FXD,FILM:4.99K OHM,1%,0.2W,TC=TO	57668	CRB20 FXE 4K99
A16R2302	313-1472-00		RES,FXD,FILM:4.7K OHM,5%,0.2W	57668	TR20JE 04K7
A16R2303	322-3231-00		RES,FXD,FILM:2.49K OHM,1%,0.2W,TC=TO	57668	CRB20 FXE 2K49
A16R2304	313-1203-00		RES,FXD,FILM:20K OHM,5%,0.2W	57668	TR20JE20K
A16R2305	313-1203-00		RES,FXD,FILM:20K OHM,5%,0.2W	57668	TR20JE20K
A16R2306	313-1472-00		RES,FXD,FILM:4.7K OHM,5%,0.2W	57668	TR20JE 04K7
A16R2307	313-1472-00		RES,FXD,FILM:4.7K OHM,5%,0.2W	57668	TR20JE 04K7
A16R2308	313-1621-00		RES,FXD,FILM:620 OHM,5%,0.2W	57668	TR20JE 620E
A16R2309	313-1101-00		RES,FXD,FILM:100 OHM,5%,0.2W	57668	TR20JE100E
A16R2310	313-1472-00		RES,FXD,FILM:4.7K OHM,5%,0.2W	57668	TR20JE 04K7
A16R2311	322-3231-00		RES,FXD,FILM:2.49K OHM,1%,0.2W,TC=TO	57668	CRB20 FXE 2K49
A16R2312	322-3252-00		RES,FXD,FILM:4.12K OHM,1%,0.2W,TC=TO	57668	CRB20 FXE 4K12
A16R2313	322-3252-00		RES,FXD,FILM:4.12K OHM,1%,0.2W,TC=TO	57668	CRB20 FXE 4K12
A16R2314	322-3231-00		RES,FXD,FILM:2.49K OHM,1%,0.2W,TC=TO	57668	CRB20 FXE 2K49
A16R2315	322-3238-00		RES,FXD,FILM:2.94K OHM,1%,0.2W,TC=TO	57668	CRB20 FXE 2K94
A16R2316	322-3231-00		RES,FXD,FILM:2.49K OHM,1%,0.2W,TC=TO	57668	CRB20 FXE 2K49
A16R2317	322-3231-00		RES,FXD,FILM:2.49K OHM,1%,0.2W,TC=TO	57668	CRB20 FXE 2K49
A16R2318	322-3238-00		RES,FXD,FILM:2.94K OHM,1%,0.2W,TC=TO	57668	CRB20 FXE 2K94
A16R2319	313-1472-00		RES,FXD,FILM:4.7K OHM,5%,0.2W	57668	TR20JE 04K7
A16R2320	313-1472-00		RES,FXD,FILM:4.7K OHM,5%,0.2W	57668	TR20JE 04K7
A16R2321	313-1472-00		RES,FXD,FILM:4.7K OHM,5%,0.2W	57668	TR20JE 04K7
A16R2322	313-1472-00		RES,FXD,FILM:4.7K OHM,5%,0.2W	57668	TR20JE 04K7
A16R2324	313-1472-00		RES,FXD,FILM:4.7K OHM,5%,0.2W	57668	TR20JE 04K7
A16R2325	307-0499-00		RES,FXD,FILM:9,100K OHM,5%,0.125W	11236	750-101-R100K
A16R2328	313-1472-00		RES,FXD,FILM:4.7K OHM,5%,0.2W	57668	TR20JE 04K7
A16R2329	313-1472-00		RES,FXD,FILM:4.7K OHM,5%,0.2W	57668	TR20JE 04K7
A16R2330	313-1472-00		RES,FXD,FILM:4.7K OHM,5%,0.2W	57668	TR20JE 04K7
A16R2331	313-1472-00		RES,FXD,FILM:4.7K OHM,5%,0.2W	57668	TR20JE 04K7
A16R2337	313-1472-00		RES,FXD,FILM:4.7K OHM,5%,0.2W	57668	TR20JE 04K7
A16R2338	313-1472-00		RES,FXD,FILM:4.7K OHM,5%,0.2W	57668	TR20JE 04K7
A16R2339	313-1472-00		RES,FXD,FILM:4.7K OHM,5%,0.2W	57668	TR20JE 04K7
A16R2340	313-1472-00		RES,FXD,FILM:4.7K OHM,5%,0.2W	57668	TR20JE 04K7
A16R2341	313-1472-00		RES,FXD,FILM:4.7K OHM,5%,0.2W	57668	TR20JE 04K7
A16R2342	313-1472-00		RES,FXD,FILM:4.7K OHM,5%,0.2W	57668	TR20JE 04K7

Component No.	Tektronix Part No.	Serial/Assembly No. Effective Dscort	Name & Description	Mfr. Code	Mfr. Part No.
A16R2343	313-1472-00		RES,FXD,FILM:4.7K OHM,5%,0.2W	57668	TR20JE 04K7
A16R2344	313-1472-00		RES,FXD,FILM:4.7K OHM,5%,0.2W	57668	TR20JE 04K7
A16R2345	313-1472-00		RES,FXD,FILM:4.7K OHM,5%,0.2W	57668	TR20JE 04K7
A16R2346	313-1472-00		RES,FXD,FILM:4.7K OHM,5%,0.2W	57668	TR20JE 04K7
A16R2347	313-1472-00		RES,FXD,FILM:4.7K OHM,5%,0.2W	57668	TR20JE 04K7
A16R2348	313-1472-00		RES,FXD,FILM:4.7K OHM,5%,0.2W	57668	TR20JE 04K7
A16R2349	313-1472-00		RES,FXD,FILM:4.7K OHM,5%,0.2W	57668	TR20JE 04K7
A16R2350	313-1472-00		RES,FXD,FILM:4.7K OHM,5%,0.2W	57668	TR20JE 04K7
A16R2351	313-1472-00		RES,FXD,FILM:4.7K OHM,5%,0.2W	57668	TR20JE 04K7
A16R2352	313-1472-00		RES,FXD,FILM:4.7K OHM,5%,0.2W	57668	TR20JE 04K7
A16R2355	313-1102-00		RES,FXD,FILM:1K OHM,5%,0.2W	57668	TR20JE01K0
A16R2356	313-1102-00		RES,FXD,FILM:1K OHM,5%,0.2W	57668	TR20JE01K0
A16R2357	313-1102-00		RES,FXD,FILM:1K OHM,5%,0.2W	57668	TR20JE01K0
A16R2361	313-1472-00		RES,FXD,FILM:4.7K OHM,5%,0.2W	57668	TR20JE 04K7
A16R2362	313-1472-00		RES,FXD,FILM:4.7K OHM,5%,0.2W	57668	TR20JE 04K7
A16R2363	313-1472-00		RES,FXD,FILM:4.7K OHM,5%,0.2W	57668	TR20JE 04K7
A16R2364	313-1472-00		RES,FXD,FILM:4.7K OHM,5%,0.2W	57668	TR20JE 04K7
A16R2365	313-1472-00		RES,FXD,FILM:4.7K OHM,5%,0.2W	57668	TR20JE 04K7
A16R2400	313-1472-00		RES,FXD,FILM:4.7K OHM,5%,0.2W	57668	TR20JE 04K7
A16R2401	313-1472-00		RES,FXD,FILM:4.7K OHM,5%,0.2W	57668	TR20JE 04K7
A16R2402	313-1472-00		RES,FXD,FILM:4.7K OHM,5%,0.2W	57668	TR20JE 04K7
A16R2404	313-1472-00		RES,FXD,FILM:4.7K OHM,5%,0.2W	57668	TR20JE 04K7
A16R2405	313-1621-00		RES,FXD,FILM:620 OHM,5%,0.2W	57668	TR20JE 620E
A16R2406	322-3220-00		RES,FXD,FILM:1.91K OHM,1%,0.2W,TC=TO	80009	322-3220-00
A16R2407	322-3176-00		RES,FXD,FILM:665 OHM,1%,0.2W,TC=TO	91637	CCF50-2
A16R2408	322-3172-00		RES,FXD,FILM:604 OHM,1%,0.2W,TC=TO	57668	CRB20 FXE 604E
A16R2409	322-3220-00		RES,FXD,FILM:1.91K OHM,1%,0.2W,TC=TO	80009	322-3220-00
A16R2410	322-3172-00		RES,FXD,FILM:604 OHM,1%,0.2W,TC=TO	57668	CRB20 FXE 604E
A16R2411	322-3220-00		RES,FXD,FILM:1.91K OHM,1%,0.2W,TC=TO	80009	322-3220-00
A16R2412	313-1102-00		RES,FXD,FILM:1K OHM,5%,0.2W	57668	TR20JE01K0
A16R2413	322-3202-00		RES,FXD,FILM:1.24K OHM,1%,0.2W,TC=TO	57668	CRB20 FXE 1K24
A16R2414	313-1102-00		RES,FXD,FILM:1K OHM,5%,0.2W	57668	TR20JE01K0
A16R2415	322-3202-00		RES,FXD,FILM:1.24K OHM,1%,0.2W,TC=TO	57668	CRB20 FXE 1K24
A16R2416	313-1102-00		RES,FXD,FILM:1K OHM,5%,0.2W	57668	TR20JE01K0
A16R2417	322-3202-00		RES,FXD,FILM:1.24K OHM,1%,0.2W,TC=TO	57668	CRB20 FXE 1K24
A16R2418	322-3077-00		RES,FXD,FILM:61.9 OHM,1%,0.2W,TC=TO	91637	CCF1G61R90F 0F
A16R2419	313-1101-00		RES,FXD,FILM:100 OHM,5%,0.2W	57668	TR20JE100E
A16R2420	313-1101-00		RES,FXD,FILM:100 OHM,5%,0.2W	57668	TR20JE100E
A16R2421	313-1621-00		RES,FXD,FILM:620 OHM,5%,0.2W	57668	TR20JE 620E
A16R2501	313-1621-00		RES,FXD,FILM:620 OHM,5%,0.2W	57668	TR20JE 620E
A16R2502	313-1472-00		RES,FXD,FILM:4.7K OHM,5%,0.2W	57668	TR20JE 04K7
A16R2503	313-1621-00		RES,FXD,FILM:620 OHM,5%,0.2W	57668	TR20JE 620E
A16R2504	313-1472-00		RES,FXD,FILM:4.7K OHM,5%,0.2W	57668	TR20JE 04K7
A16R2505	313-1621-00		RES,FXD,FILM:620 OHM,5%,0.2W	57668	TR20JE 620E
A16R2506	313-1621-00		RES,FXD,FILM:620 OHM,5%,0.2W	57668	TR20JE 620E
A16R2507	313-1101-00		RES,FXD,FILM:100 OHM,5%,0.2W	57668	TR20JE100E
A16R2508	313-1102-00		RES,FXD,FILM:1K OHM,5%,0.2W	57668	TR20JE01K0
A16R2509	313-1102-00		RES,FXD,FILM:1K OHM,5%,0.2W	57668	TR20JE01K0
A16R2510	313-1511-00		RES,FXD,FILM:510 OHM,5%,0.2W	57668	TR20JT68 510E
A16R2511	313-1102-00		RES,FXD,FILM:1K OHM,5%,0.2W	57668	TR20JE01K0
A16R2512	313-1472-00		RES,FXD,FILM:4.7K OHM,5%,0.2W	57668	TR20JE 04K7
A16R2513	313-1472-00		RES,FXD,FILM:4.7K OHM,5%,0.2W	57668	TR20JE 04K7
A16R2514	313-1621-00		RES,FXD,FILM:620 OHM,5%,0.2W	57668	TR20JE 620E
A16R2515	313-1621-00		RES,FXD,FILM:620 OHM,5%,0.2W	57668	TR20JE 620E
A16R2516	313-1621-00		RES,FXD,FILM:620 OHM,5%,0.2W	57668	TR20JE 620E
A16R2517	313-1621-00		RES,FXD,FILM:620 OHM,5%,0.2W	57668	TR20JE 620E
A16R2518	313-1102-00		RES,FXD,FILM:1K OHM,5%,0.2W	57668	TR20JE01K0
A16R2519	313-1621-00		RES,FXD,FILM:620 OHM,5%,0.2W	57668	TR20JE 620E

Replaceable Electrical Parts - 2247A Service

Component No.	Tektronix Part No.	Serial/Assembly No. Effective Dscont	Name & Description	Mfr. Code	Mfr. Part No.
A16R2520	307-0499-00		RES,FXD,FILM:9,100K OHM,5%,0.125W	11236	750-101-R100K
A16R2521	307-0499-00		RES,FXD,FILM:9,100K OHM,5%,0.125W	11236	750-101-R100K
A16R2522	307-0499-00		RES,FXD,FILM:9,100K OHM,5%,0.125W	11236	750-101-R100K
A16R2523	313-1102-00		RES,FXD,FILM:1K OHM,5%,0.2W	57668	TR20JE01KO
A16R2524	313-1102-00		RES,FXD,FILM:1K OHM,5%,0.2W	57668	TR20JE01KO
A16R2525	313-1621-00		RES,FXD,FILM:620 OHM,5%,0.2W	57668	TR20JE 620E
A16R2526	313-1621-00		RES,FXD,FILM:620 OHM,5%,0.2W	57668	TR20JE 620E
A16R2527	313-1621-00		RES,FXD,FILM:620 OHM,5%,0.2W	57668	TR20JE 620E
A16R2528	313-1621-00		RES,FXD,FILM:620 OHM,5%,0.2W	57668	TR20JE 620E
A16R2529	313-1621-00		RES,FXD,FILM:620 OHM,5%,0.2W	57668	TR20JE 620E
A16R2532	313-1102-00		RES,FXD,FILM:1K OHM,5%,0.2W	57668	TR20JE01KO
A16R2534	313-1102-00		RES,FXD,FILM:1K OHM,5%,0.2W	57668	TR20JE01KO
A16R2536	313-1102-00		RES,FXD,FILM:1K OHM,5%,0.2W	57668	TR20JE01KO
A16R2538	313-1102-00		RES,FXD,FILM:1K OHM,5%,0.2W	57668	TR20JE01KO
A16R2540	313-1102-00		RES,FXD,FILM:1K OHM,5%,0.2W	57668	TR20JE01KO
A16R2542	313-1102-00		RES,FXD,FILM:1K OHM,5%,0.2W	57668	TR20JE01KO
A16R2546	313-1220-00		RES,FXD,FILM:22 OHM,5%,0.2W	57668	TR20JE22E
A16R2547	313-1220-00		RES,FXD,FILM:22 OHM,5%,0.2W	57668	TR20JE22E
A16R2548	313-1220-00		RES,FXD,FILM:22 OHM,5%,0.2W	57668	TR20JE22E
A16R2549	313-1220-00		RES,FXD,FILM:22 OHM,5%,0.2W	57668	TR20JE22E
A16R2550	313-1220-00		RES,FXD,FILM:22 OHM,5%,0.2W	57668	TR20JE22E
A16R2551	313-1220-00		RES,FXD,FILM:22 OHM,5%,0.2W	57668	TR20JE22E
A16R2552	313-1220-00		RES,FXD,FILM:22 OHM,5%,0.2W	57668	TR20JE22E
A16R2553	313-1220-00		RES,FXD,FILM:22 OHM,5%,0.2W	57668	TR20JE22E
A16R2554	313-1102-00		RES,FXD,FILM:1K OHM,5%,0.2W	57668	TR20JE01KO
A16R2555	313-1101-00		RES,FXD,FILM:100 OHM,5%,0.2W	57668	TR20JE100E
A16R2560	313-1101-00		RES,FXD,FILM:100 OHM,5%,0.2W	57668	TR20JE100E
A16R2561	313-1101-00		RES,FXD,FILM:100 OHM,5%,0.2W	57668	TR20JE100E
A16R2562	313-1101-00		RES,FXD,FILM:100 OHM,5%,0.2W	57668	TR20JE100E
A16R2563	313-1101-00		RES,FXD,FILM:100 OHM,5%,0.2W	57668	TR20JE100E
A16R2564	313-1101-00		RES,FXD,FILM:100 OHM,5%,0.2W	57668	TR20JE100E
A16U1901	156-1647-00		MICROCKT,LINEAR:COMPARATOR,QUAD	04713	MC3431P
A16U1902	156-3573-00		MICROCKT,DGTL:CMOS,SEMI CUSTOM,STD CELL	80009	156-3573-00
A16U1903	156-1647-00		MICROCKT,LINEAR:COMPARATOR,QUAD	04713	MC3431P
A16U1904	156-1647-00		MICROCKT,LINEAR:COMPARATOR,QUAD	04713	MC3431P
A16U1905	156-3574-00		MICROCKT,DGTL:BIPOLAR,SEMI CUSTOM	80009	156-3574-00
A16U2300	156-1646-00		MICROCKT,DGTL:HCCMOS,OCTAL D TYPE FF	TK0273	MD74HCT374RE
A16U2301	156-1646-00		MICROCKT,DGTL:HCCMOS,OCTAL D TYPE FF	TK0273	MD74HCT374RE
A16U2302	156-1589-00		MICROCKT,LINEAR:D/A CONVERTER,12 BIT,HIGH S PEED,MONOLITHIC	06665	DAC312FR
A16U2303	156-0513-00		IC,MISC:CMOS,ANALOG MUX;8 CHANNEL;CD4051,DI P16.3	04713	MC14051BCL
A16U2304	156-1200-00		MICROCKT,LINEAR:BIFET,QUAD OPNL AMPL	01295	TL074CN
A16U2305	156-1200-00		MICROCKT,LINEAR:BIFET,QUAD OPNL AMPL	01295	TL074CN
A16U2306	156-1126-00		MICROCKT,LINEAR:VOLTAGE COMPARATOR	01295	LM311P
A16U2308	156-0513-00		IC,MISC:CMOS,ANALOG MUX;8 CHANNEL;CD4051,DI P16.3	04713	MC14051BCL
A16U2309	156-0513-00		IC,MISC:CMOS,ANALOG MUX;8 CHANNEL;CD4051,DI P16.3	04713	MC14051BCL
A16U2313	156-1646-00		MICROCKT,DGTL:HCCMOS,OCTAL D TYPE FF	TK0273	MD74HCT374RE
A16U2314	156-1149-00		MICROCKT,LINEAR:OPERATIONAL AMP,JFET INPUT	27014	LF351N/GLEA134
A16U2400	160-3493-00		MICROCKT,DGTL:8 BIT MICROCOMPUTER,MASKED F OR READOUT SYSTEM	80009	160-3493-00
A16U2401	156-1646-00		MICROCKT,DGTL:HCCMOS,OCTAL D TYPE FF	TK0273	MD74HCT374RE
A16U2402	156-1646-00		MICROCKT,DGTL:HCCMOS,OCTAL D TYPE FF	TK0273	MD74HCT374RE
A16U2403	156-1646-00		MICROCKT,DGTL:HCCMOS,OCTAL D TYPE FF	TK0273	MD74HCT374RE
A16U2404	156-0412-00		IC,DIGITAL:LSTTL,COUNTER;SYNCH 4-BIT UP/DOWN BINARY;74LS193,DIP16.3 TUBE	80009	156-0412-00

Component No.	Tektronix Part No.	Serial/Assembly No. Effective	Dscont	Name & Description	Mfr. Code	Mfr. Part No.
A16U2405	156-0412-00			IC,DIGITAL:LSTTL,COUNTER;SYNCH 4-BIT UP/DOWN BINARY;74LS193,DIP16.3 TUBE	80009	156-0412-00
A16U2406	156-1594-00	B010100	B010614	IC,MEMORY:NMOS,SRAM;2K X 8,150NS;,DIP24.6	65786	CY6116-55PC
A16U2406	156-2016-00	B010615		IC,MEMORY:NMOS,SRAM;2K X 8,100NS,OE;,DIP24.6	TK1016	TMM2016AP-10
A16U2407	156-1172-00			IC,DIGITAL:LSTTL,COUNTER;DUAL 4-BIT BINARY; 74LS393,DIP14.3,TUBE	80009	156-1172-00
A16U2408	160-5391-00			MICROCKT,DGTL:NMOS,4096 X 8 EPROM,PRGM	80009	160-5391-00
A16U2409	156-1172-00			IC,DIGITAL:LSTTL,COUNTER;DUAL 4-BIT BINARY; 74LS393,DIP14.3,TUBE	80009	156-1172-00
A16U2410	160-4085-00			MICROCKT,DGTL:TTL,OCTAL 16 INPUT REGISTERED AND/OR	80009	160-4085-00
A16U2411	156-1646-00			MICROCKT,DGTL:HCCMOS,OCTAL D TYPE FF	TK0273	MD74HCT374RE
A16U2412	156-1255-00			MICROCKT,LINEAR:D/A CONVERTER,8 BIT	06665	DAC08-157Q
A16U2413	156-1255-00			MICROCKT,LINEAR:D/A CONVERTER,8 BIT	06665	DAC08-157Q
A16U2414	156-0514-00			IC,MISC:CMOS,ANALOG MUX;DUAL 4 CHANNEL;CD40 52,DIP16.3	02735	CD4052BF-98
A16U2415	156-0514-00			IC,MISC:CMOS,ANALOG MUX;DUAL 4 CHANNEL;CD40 52,DIP16.3	02735	CD4052BF-98
A16U2416	156-1200-00			MICROCKT,LINEAR:BIFET,QUAD OPNL AMPL	01295	TL074CN
A16U2417	156-0382-00			IC,DIGITAL:LSTTL,GATES;QUAD 2-INPUT NAND;74 LS00,DIP14.3,TUBE	01295	SN74LS00(N OR J)
A16U2501	156-2003-01			MICROCKT,DGTL:MOS,8 BIT MICROPRC,8 MHZ	34335	R80188
A16U2502	156-2396-00			MICROCKT,LINEAR:BIPOLAR,MPU RESET GENERATOR	01295	TL7705 ACP
A16U2503	156-0479-00			IC,DIGITAL:LSTTL,GATES;QUAD 2-INPUT OR;74LS 32,DIP14.3,TUBE	80009	156-0479-00
A16U2506	156-0382-00			IC,DIGITAL:LSTTL,GATES;QUAD 2-INPUT NAND;74 LS00,DIP14.3,TUBE	01295	SN74LS00(N OR J)
A16U2512	156-1065-00			IC,DIGITAL:LSTTL,LATCH;OCTAL D-TYPE TRANSPA RENT, 3-STATE;74LS373,DIP20.3,TUBE	01295	SN74LS373N
A16U2513	156-1065-00			IC,DIGITAL:LSTTL,LATCH;OCTAL D-TYPE TRANSPA RENT, 3-STATE;74LS373,DIP20.3,TUBE	01295	SN74LS373N
A16U2514	156-1111-00			MICROCKT,DGTL:OCTAL BUS TRANSCEIVERS	01295	SN74LS245N
A16U2515	156-1111-00			MICROCKT,DGTL:OCTAL BUS TRANSCEIVERS	01295	SN74LS245N
A16U2517	156-0469-00			IC,DIGITAL:LSTTL,DEMUX/DECODER;3-TO-8 DECOD ER;74LS138,DIP16.3,TUBE	01295	SN74LS138N
A16U2518	156-0469-00			IC,DIGITAL:LSTTL,DEMUX/DECODER;3-TO-8 DECOD ER;74LS138,DIP16.3,TUBE	01295	SN74LS138N
A16U2519	160-5663-01			MICROCKT,DGTL:NMOS,131072 X 8 EPROM,PRGM 27 010,DIP32.6	80009	160-5663-01
A16U2521	156-2473-00			IC,MEMORY:CMOS,SRAM;8K X 8,200NS,10UA,OE;,D IP28.6	TK0961	uPD4464C-20
A16U2523	156-1646-00			MICROCKT,DGTL:HCCMOS,OCTAL D TYPE FF	TK0273	MD74HCT374RE
A16U2524	156-1646-00			MICROCKT,DGTL:HCCMOS,OCTAL D TYPE FF	TK0273	MD74HCT374RE
A16U2525	156-1058-00			IC,DIGITAL:STTL,BUFFER/DRIVER;INV OCTAL, LI NE DRIVER, 3-STATE;74S240,DIP20.3,TUBE	80009	156-1058-00
A16W2105	174-1040-00			CA ASSY,SP,ELEC:17 COND,5.1 L,RIBBON	80009	174-1040-00
A16XU2400	136-0755-00			SKT,PL-IN ELEK:MICROCIRCUIT,28 DIP	09922	D1LB28P-108
A16XU2501	136-0813-00			SKT,PL-IN ELEK:CHIP CARRIER,68 CONTACTS	19613	268-5400-00-1102
A16XU2519	136-0963-00			SKT,PL-IN ELEK:MICROCKT,32 PIN	TK1650	2-644018-3
A16XY1901	352-0096-00			HLDR,XTAL UNIT:CIRCUIT BOARD	80009	352-0096-00
A16Y1901	158-0129-00			XTAL UNIT,QTZ:10MHZ 0.001%,PARALLEL	00136	20-9-1
A16Y2501	119-2936-00			RESONATOR:16MHZ,CER	80009	119-2936-00
A18	670-9398-04			CIRCUIT BD ASSY:LV POWER SUPPLY	80009	670-9398-04
A18C2201	285-1177-01			CAP,FXD,PLASTIC:1UF,10%,450V	80009	285-1177-01
A18C2202	290-1206-00			CAP,FXD,ELCTLT:270UF,20%,450V	TK0900	

Replaceable Electrical Parts - 2247A Service

Component No.	Tektronix Part No.	Serial/Assembly No. Effective Dscnt	Name & Description	Mfr. Code	Mfr. Part No.
A18C2203	290-0922-01		CAP, FXD, ELCLTL: 1000UF, 4100% -10%, 50V	56289	674D108H050JJ5A
A18C2204	290-1151-00		CAP, FXD, ELCLTL: 100UF, 20%, 63V	55680	UEB1J101MRAICA
A18C2206	281-0775-01		CAP, FXD, CER DI: 0.1UF, 20%, 50V	04222	SA105E104MAA
A18C2207	281-0775-01		CAP, FXD, CER DI: 0.1UF, 20%, 50V	04222	SA105E104MAA
A18C2208	290-1144-00		CAP, FXD, ELCLTL: 4.7UF, 20%, 100V	80009	290-1144-00
A18C2209	281-0773-00		CAP, FXD, CER DI: 0.01UF, 10%, 100V	04222	MA201C103KAA
A18C2210	290-1144-00		CAP, FXD, ELCLTL: 4.7UF, 20%, 100V	80009	290-1144-00
A18C2211	281-0773-00		CAP, FXD, CER DI: 0.01UF, 10%, 100V	04222	MA201C103KAA
A18C2212	281-0761-00		CAP, FXD, CER DI: 27PF, 5%, 100V	04222	MA101A270JAA
A18C2213	285-1381-00		CAP, FXD, MTLZD: 1500PF, 10%, 250V	TK0515	PME271Y415
A18C2214	285-1381-00		CAP, FXD, MTLZD: 1500PF, 10%, 250V	TK0515	PME271Y415
A18C2215	285-1252-00		CAP, FXD, PLASTIC: 0.15UF, 10%, 250VAC	D5243	F1772-415-2000
A18C2216	285-1252-00		CAP, FXD, PLASTIC: 0.15UF, 10%, 250VAC	D5243	F1772-415-2000
A18C2217	285-1381-00		CAP, FXD, MTLZD: 1500PF, 10%, 250V	TK0515	PME271Y415
A18C2218	281-0813-00		CAP, FXD, CER DI: 0.047UF, 20%, 50V	05397	C412C473M5V2CA
A18C2219	281-0773-00		CAP, FXD, CER DI: 0.01UF, 10%, 100V	04222	MA201C103KAA
A18C2221	290-1129-00		CAP, FXD, ELCLTL: 1000UF, +100%-10%, 12V	56289	ORDER BY DESCR
A18C2222	290-1129-00		CAP, FXD, ELCLTL: 1000UF, +100%-10%, 12V	56289	ORDER BY DESCR
A18C2223	290-1129-00		CAP, FXD, ELCLTL: 1000UF, +100%-10%, 12V	56289	ORDER BY DESCR
A18C2224	290-1129-00		CAP, FXD, ELCLTL: 1000UF, +100%-10%, 12V	56289	ORDER BY DESCR
A18C2225	290-1129-00		CAP, FXD, ELCLTL: 1000UF, +100%-10%, 12V	56289	ORDER BY DESCR
A18C2226	290-1129-00		CAP, FXD, ELCLTL: 1000UF, +100%-10%, 12V	56289	ORDER BY DESCR
A18C2227	290-1129-00		CAP, FXD, ELCLTL: 1000UF, +100%-10%, 12V	56289	ORDER BY DESCR
A18C2228	290-1129-00		CAP, FXD, ELCLTL: 1000UF, +100%-10%, 12V	56289	ORDER BY DESCR
A18C2229	290-1128-00		CAP, FXD, ELCLTL: 470UF, +100%, 25V	56289	ORDER BY DESCR
A18C2230	290-1128-00		CAP, FXD, ELCLTL: 470UF, +100%, 25V	56289	ORDER BY DESCR
A18C2232	290-1130-00		CAP, FXD, ELCLTL: 39UF, +100%-10%, 150V	56289	ORDER BY DESCR
A18C2233	290-1130-00		CAP, FXD, ELCLTL: 39UF, +100%-10%, 150V	56289	ORDER BY DESCR
A18C2234	290-1128-00		CAP, FXD, ELCLTL: 470UF, +100%, 25V	56289	ORDER BY DESCR
A18C2236	290-1128-00		CAP, FXD, ELCLTL: 470UF, +100%, 25V	56289	ORDER BY DESCR
A18C2238	290-1144-00		CAP, FXD, ELCLTL: 4.7UF, 20%, 100V	80009	290-1144-00
A18C2239	281-0775-01		CAP, FXD, CER DI: 0.1UF, 20%, 50V	04222	SA105E104MAA
A18C2243	281-0770-00		CAP, FXD, CER DI: 1000PF, 20%, 100V	04222	MA101C102MAA
A18C2244	285-1184-01		CAP, FXD, MTLZD: 0.01UF, 20%, 4KV	56289	430P103X040
A18C2245	285-1184-01		CAP, FXD, MTLZD: 0.01UF, 20%, 4KV	56289	430P103X040
A18C2248	290-1151-00		CAP, FXD, ELCLTL: 100UF, 20%, 63V	55680	UEB1J101MRAICA
A18C2249	281-0773-00		CAP, FXD, CER DI: 0.01UF, 10%, 100V	04222	MA201C103KAA
A18CR2201	152-0661-01		SEMICON DVC, DI: RECT, SI, 600V, 3A	80009	152-0661-01
A18CR2202	152-0400-00		SEMICON DVC, DI: RECT, SI, 400V, 1A	14552	MB2501
A18CR2204	152-0400-00		SEMICON DVC, DI: RECT, SI, 400V, 1A	14552	MB2501
A18CR2205	152-0400-00		SEMICON DVC, DI: RECT, SI, 400V, 1A	14552	MB2501
A18CR2206	152-0582-00		SEMICON DVC, DI: RECT, SI, 20V, 3A, SCHOTTKY	80009	152-0582-00
A18CR2207	152-0582-00		SEMICON DVC, DI: RECT, SI, 20V, 3A, SCHOTTKY	80009	152-0582-00
A18CR2208	152-0400-00		SEMICON DVC, DI: RECT, SI, 400V, 1A	14552	MB2501
A18CR2209	152-0400-00		SEMICON DVC, DI: RECT, SI, 400V, 1A	14552	MB2501
A18CR2210	152-0400-00		SEMICON DVC, DI: RECT, SI, 400V, 1A	14552	MB2501
A18CR2211	152-0400-00		SEMICON DVC, DI: RECT, SI, 400V, 1A	14552	MB2501
A18CR2212	152-0400-00		SEMICON DVC, DI: RECT, SI, 400V, 1A	14552	MB2501
A18CR2213	152-0400-00		SEMICON DVC, DI: RECT, SI, 400V, 1A	14552	MB2501
A18CR2214	152-0400-00		SEMICON DVC, DI: RECT, SI, 400V, 1A	14552	MB2501
A18CR2215	152-0400-00		SEMICON DVC, DI: RECT, SI, 400V, 1A	14552	MB2501
A18CR2216	152-0400-00		SEMICON DVC, DI: RECT, SI, 400V, 1A	14552	MB2501
A18CR2218	152-0400-00		SEMICON DVC, DI: RECT, SI, 400V, 1A	14552	MB2501
A18CR2219	152-0581-00		SEMICON DVC, DI: RECT, SI, 20V, 1A, A59	04713	1N5817
A18CR2220	152-0581-00		SEMICON DVC, DI: RECT, SI, 20V, 1A, A59	04713	1N5817
A18CR2227	152-0400-00		SEMICON DVC, DI: RECT, SI, 400V, 1A	14552	MB2501
A18CR2228	152-0400-00		SEMICON DVC, DI: RECT, SI, 400V, 1A	14552	MB2501
A18CR2231	152-0040-00		SEMICON DVC, DI: RECT, SI, 600V, 1A, D0-41	80009	152-0040-00

Component No.	Tektronix Part No.	Serial/Assembly No. Effective	Dscont	Name & Description	Mfr. Code	Mfr. Part No.
A18CR2232	152-0040-00			SEMICON DVC,DI:RECT,SI,600V,1A,DO-41	80009	152-0040-00
A18CR2233	152-0040-00			SEMICON DVC,DI:RECT,SI,600V,1A,DO-41	80009	152-0040-00
A18CR2234	152-0040-00			SEMICON DVC,DI:RECT,SI,600V,1A,DO-41	80009	152-0040-00
A18CR2235	152-0400-00			SEMICON DVC,DI:RECT,SI,400V,1A	14552	MB2501
A18CR2236	152-0400-00			SEMICON DVC,DI:RECT,SI,400V,1A	14552	MB2501
A18CR2237	152-0141-02			SEMICON DVC,DI:SW,SI,30V,150MA,30V,DO-35	03508	DA2527 (1N4152)
A18DS2201	150-0035-00			LAMP,GLOW:90V MAX,0.3MA,AID-T,WIRE LD	TK0213	JH005/3011JA
A18J2208	131-3645-00			CONN,RCPT,ELEC:3 POSITION,0.01 SPACING	80009	131-3645-00
A18J2225	131-3486-00			CONN,RCPT,ELEC:HEADER,RTANG,2 POS,0.1 SPACING	00779	640452-2
A18L2201	108-1324-00			COIL,RF:FXD,33UH,POWER	54583	0L1338-330K5R0
A18L2202	108-1319-00			INDUCTOR,FIXED:33UH,10%,1.8A	80009	108-1319-00
A18L2203	108-1319-00			INDUCTOR,FIXED:33UH,10%,1.8A	80009	108-1319-00
A18L2204	108-1319-00			INDUCTOR,FIXED:33UH,10%,1.8A	80009	108-1319-00
A18L2205	108-1319-00			INDUCTOR,FIXED:33UH,10%,1.8A	80009	108-1319-00
A18L2206	108-1396-00	B010100	B021651	INDUCTOR,FIXED:150UH,0.82A	TK2058	TSL1110-151KR82
A18L2206	108-1319-00	B020652		INDUCTOR,FIXED:33UH,10%,1.8A	80009	108-1319-00
A18L2207	108-1357-00			COIL,RF:FXD,POWER	TK1441	86-343-2
A18L2208	108-1357-00			COIL,RF:FXD,POWER	TK1441	86-343-2
A18P2204	131-3637-00			CONN,RCPT,ELEC:HEADER,13 CIRCUIT,0.156 SPACING	80009	131-3637-00
A18Q2201	151-1214-00			TRANSISTOR:MOSFET,SI,TO-220	80009	151-1214-00
A18Q2202	151-0190-00			TRANSISTOR:NPN,SI,TO-92	80009	151-0190-00
A18Q2203	151-0188-00			TRANSISTOR:PNP,SI,TO-92	80009	151-0188-00
A18Q2204	151-0190-00			TRANSISTOR:NPN,SI,TO-92	80009	151-0190-00
A18Q2206	151-0565-00			THYRISTOR,SCR:8A,200V,SENS GATE,TO-220 W/LEADFORM	80009	151-0565-00
A18Q2208	151-0190-00			TRANSISTOR:NPN,SI,TO-92	80009	151-0190-00
A18Q2209	151-0476-03			TRANSISTOR:POWER,W/LEAD FORM,TO-220	80009	151-0476-03
A18Q2210	151-0476-03			TRANSISTOR:POWER,W/LEAD FORM,TO-220	80009	151-0476-03
A18Q2211	151-0188-00			TRANSISTOR:PNP,SI,TO-92	80009	151-0188-00
A18Q2212	151-0276-01			TRANSISTOR:PNP,SI,TO-92	TK1016	S1423-TPE2
A18Q2213	151-0276-01			TRANSISTOR:PNP,SI,TO-92	TK1016	S1423-TPE2
A18Q2214	151-1197-00			TRANSISTOR:FET,MOS PWR,N-CHAN,TO-220	04713	IRF533WLEADFORM
A18R2201	308-0678-00			RES,FXD,WM:0.1 OHM,5%,2W	75042	BWH-R1000J
A18R2203	301-0184-00			RES,FXD,FILM:180K OHM,5%,0.5W	57668	TR50J-E180K
A18R2204	301-0184-00			RES,FXD,FILM:180K OHM,5%,0.5W	57668	TR50J-E180K
A18R2205	313-1104-00			RES,FXD,FILM:100K OHM,5%,0.2W	57668	TR20JE100K
A18R2206	313-1104-00			RES,FXD,FILM:100K OHM,5%,0.2W	57668	TR20JE100K
A18R2207	322-3164-00			RES,FXD,FILM:499 OHM,1%,0.2W,TC=TO	57668	CRB20 FXE 499E
A18R2208	313-1102-00			RES,FXD,FILM:1K OHM,5%,0.2W	57668	TR20JE01K0
A18R2209	313-1104-00			RES,FXD,FILM:100K OHM,5%,0.2W	57668	TR20JE100K
A18R2210	313-1513-00			RES,FXD,CMPSN:51K OHM,5%,0.2W	57668	TR20JE 51K
A18R2211	313-1332-00			RES,FXD,FILM:3.3K OHM,5%,0.2W	57668	TR20JE 03K3
A18R2212	313-1822-00			RES,FXD,FILM:8.2K,OHM,5%,0.2W	57668	TR20JE 08K2
A18R2215	313-1272-00	B010100	B010684	RES,FXD,FILM:2.7K OHM,5%,0.2W	57668	TR20JE 02K7
A18R2215	313-1222-00	B010685		RES,FXD,FILM:2.2K OHM,5%,0.2W	57668	TR20JE 02K2
A18R2216	313-1102-00			RES,FXD,FILM:1K OHM,5%,0.2W	57668	TR20JE01K0
A18R2218	313-1101-00			RES,FXD,FILM:100 OHM,5%,0.2W	57668	TR20JE100E
A18R2219	313-1105-00			RES,FXD,FILM:1M OHM,5%,0.2W	57668	TR20JE1M
A18R2220	313-1105-00			RES,FXD,FILM:1M OHM,5%,0.2W	57668	TR20JE1M
A18R2221	313-1203-00			RES,FXD,FILM:20K OHM,5%,0.2W	57668	TR20JE20K
A18R2222	313-1103-00			RES,FXD,FILM:10K OHM,5%,0.2W	57668	TR20JE10K0
A18R2223	313-1105-00			RES,FXD,FILM:1M OHM,5%,0.2W	57668	TR20JE1M
A18R2224	313-1101-00			RES,FXD,FILM:100 OHM,5%,0.2W	57668	TR20JE100E
A18R2225	313-1101-00			RES,FXD,FILM:100 OHM,5%,0.2W	57668	TR20JE100E
A18R2226	301-0274-00			RES,FXD,FILM:270K OHM,5%,0.5W	19701	5053CX270K0J
A18R2227	313-1102-00			RES,FXD,FILM:1K OHM,5%,0.2W	57668	TR20JE01K0

Replaceable Electrical Parts - 2247A Service

Component No.	Tektronix Part No.	Serial/Assembly No. Effective Dscnt	Name & Description	Mfr. Code	Mfr. Part No.
A18R2228	313-1102-00		RES,FXD,FILM:1K OHM,5%,0.2W	57668	TR20JE01K0
A18R2229	301-0823-00		RES,FXD,FILM:82K OHM,5%,0.5W	19701	5053CX82K00J
A18R2230	301-0823-00		RES,FXD,FILM:82K OHM,5%,0.5W	19701	5053CX82K00J
A18R2231	315-0101-03		RES,FXD,CMPSN:100 OHM,5%,0.25W	01121	CB1015
A18R2232	313-1102-00		RES,FXD,FILM:1K OHM,5%,0.2W	57668	TR20JE01K0
A18R2233	313-1103-00		RES,FXD,FILM:10K OHM,5%,0.2W	57668	TR20JE10K0
A18R2236	313-1104-00		RES,FXD,FILM:100K OHM,5%,0.2W	57668	TR20JE100K
A18R2237	313-1105-00		RES,FXD,FILM:1M OHM,5%,0.2W	57668	TR20JE1M
A18R2238	313-1753-00		RES,FXD,FILM:75K OHM,5%,0.2W	57668	TR20JE 75K
A18R2239	313-1103-00		RES,FXD,FILM:10K OHM,5%,0.2W	57668	TR20JE10K0
A18R2240	313-1204-00		RES,FXD,FILM:200K,5%,0.2W	57668	TR20JE 200K
A18R2241	313-1103-00		RES,FXD,FILM:10K OHM,5%,0.2W	57668	TR20JE10K0
A18R2242	313-1027-00		RES,FXD,FILM:2.7 OHM,5%,0.2W	57668	TR20JE 02E7
A18R2243	313-1027-00		RES,FXD,FILM:2.7 OHM,5%,0.2W	57668	TR20JE 02E7
A18R2245	313-1103-00		RES,FXD,FILM:10K OHM,5%,0.2W	57668	TR20JE10K0
A18R2246	313-1513-00		RES,FXD,CMPSN:51K OHM,5%,0.2W	57668	TR20JE 51K
A18R2247	322-3289-00		RES,FXD,FILM:10K OHM,1%,0.2W,TC=TO	57668	CRB20 FXE 10K0
A18R2248	313-1513-00		RES,FXD,CMPSN:51K OHM,5%,0.2W	57668	TR20JE 51K
A18R2250	301-0106-00		RES,FXD,FILM:10M OHM,5%,0.50W	01121	EB1065
A18R2252	311-2270-00		RES,VAR,NONW:TRMR,10K OHM,20%,0.5W	80009	311-2270-00
A18R2253	313-1101-00		RES,FXD,FILM:100 OHM,5%,0.2W	57668	TR20JE100E
A18R2254	313-1051-00		RES,FXD,FILM:5.1 OHM,5%,0.2W	57668	TR20JT68 05E1
A18R2255	313-1051-00		RES,FXD,FILM:5.1 OHM,5%,0.2W	57668	TR20JT68 05E1
A18R2256	301-0274-00		RES,FXD,FILM:270K OHM,5%,0.5W	19701	5053CX270K0J
A18R2257	301-0200-00		RES,FXD,FILM:20 OHM,5%,0.5W	19701	5053CX20R00J
A18R2259	315-0472-03		RES,FXD,CMPSN:4.7K OHM,5%,0.25W	01121	CB4725
A18R2260	301-0560-00		RES,FXD,FILM:56 OHM,5%,0.5W	19701	5053CX56R00J
A18R2265	313-1101-00		RES,FXD,FILM:100 OHM,5%,0.2W	57668	TR20JE100E
A18R2266	315-0472-03		RES,FXD,CMPSN:4.7K OHM,5%,0.25W	01121	CB4725
A18R2267	307-0113-00		RES,FXD,CMPSN:5.1 OHM,5%,0.25W	01121	CB51G5
A18R2268	313-1103-00		RES,FXD,FILM:10K OHM,5%,0.2W	57668	TR20JE10K0
A18R2270	313-1103-00		RES,FXD,FILM:10K OHM,5%,0.2W	57668	TR20JE10K0
A18R2271	313-1512-00		RES,FXD,FILM:5.1K OHM,5%,0.2W	57668	TR20JE 5K1
A18R2272	313-1051-00		RES,FXD,FILM:5.1 OHM,5%,0.2W	57668	TR20JT68 05E1
A18R2273	313-1051-00		RES,FXD,FILM:5.1 OHM,5%,0.2W	57668	TR20JT68 05E1
A18R2274	313-1103-00		RES,FXD,FILM:10K OHM,5%,0.2W	57668	TR20JE10K0
A18R2275	301-0432-00		RES,FXD,FILM:4.3K OHM,5%,0.5W	19701	5053CX4K300J
A18R2276	313-1102-00		RES,FXD,FILM:1K OHM,5%,0.2W	57668	TR20JE01K0
A18R2201	307-0863-00		RES,THERMAL:10 OHM,10%,NTC	15454	SG-13S
A18S2201	260-2443-00		SWITCH,PUSH:POWER,DPST,6A,250VAC	80009	260-2443-00
A18S2202	260-2318-00		SWITCH,THRMSTC:NC,105 DEG C OPEN,80 DEG C C LOSED,10A,240VAC	80009	260-2318-00
A18T2203	120-1686-00		TRANSFORMER,RF:COUPLED INDUCTOR	80009	120-1686-00
A18T2204	120-1685-01		XFMR,PWR,STU:HIGH VOLTAGE	75498	ORDER BY DESCR
A18T2205	120-1347-00		TRANSFORMER,RF:DRIVER SATURATING	80009	120-1347-00
A18T2206	120-1401-00		XFMR,TRIGGER:LINE,1:1 TURNS RATIO	54937	DMI 500-2044
A18U2201	156-2395-00		MICROCKT,LINEAR:BIPOLAR,PWM POWER SUPPLY,CO NTROLLER	80009	156-2395-00
A18U2230	152-0926-00		SEMICON DVC,DI:	80009	152-0926-00
A18VR2201	152-0255-00		SEMICON DVC,DI:ZEN,SI,51V,5%,0.4W,DO-7	80009	152-0255-00
A18VR2202	152-0166-00		SEMICON DVC,DI:ZEN,SI,6.2V,5%,400MW,DO-7	04713	SZ11738RL
A18VR2203	152-0304-00		SEMICON DVC,DI:ZEN,SI,20V,5%,0.4W,DO-7	15238	Z5411
A18VR2204	307-0456-00		RES,V SENSITIVE:250VAC,20W,METAL OXIDE	03508	MOV-V250LA15A
A18VR2205	152-0166-00		SEMICON DVC,DI:ZEN,SI,6.2V,5%,400MW,DO-7	04713	SZ11738RL
A18VR2206	152-0282-00		SEMICON DVC,DI:ZEN,SI,30V,2%,400MW,DO-35 O R DO-7	14552	1N972B
A18VR2207	152-0304-00		SEMICON DVC,DI:ZEN,SI,20V,5%,0.4W,DO-7	15238	Z5411
A18W28	196-3093-00		LEAD,ELECTRICAL:18 AWG,3.3 L,8-9	80009	196-3093-00

Component No.	Tektronix Part No.	Serial/Assembly No. Effective Dscnt	Name & Description	Mfr. Code	Mfr. Part No.
A18W29	196-3092-00		LEAD, ELECTRICAL:18 AWG,3.3 L,8-0	80009	196-3092-00
A18W31	196-3094-00		LEAD, ELECTRICAL:26 AWG,2.6 L,9-N	80009	196-3094-00
A18W32	196-3094-00		LEAD, ELECTRICAL:26 AWG,2.6 L,9-N	80009	196-3094-00
A18W2201	131-0566-00		BUS, CONDUCTOR:DUMMY RES,0.094 OD X 0.225 L	24546	OMA 07
A25E1502	276-0635-00	B020340	CORE, EM: TOROID, FERRITE	02114	768 T188/3E2A
B25	119-2063-00		FAN, TUBEAXIAL:12V,130MA,19.4 CFM	61529	A1F891003
DL21	119-2118-01		DELAY LINE, ELEC:	80009	119-2118-01
F2201	159-0023-00		FUSE, CARTRIDGE:3AG,2A,250V,SLOW BLOW	71400	MDX2
FL2201	119-2055-00		FILTER, RFI:3A,115-230V,48-440HZ	05245	3EF1F
J16	131-0955-00		CONN, RCPT, ELEC:BNC, FEMALE	13511	31-279
J19	131-0955-00		CONN, RCPT, ELEC:BNC, FEMALE	13511	31-279
V1	154-0905-00		ELECTRON TUBE:CRT	80009	154-0905-00
W30	195-3990-00		LEAD, ELECTRICAL:18 AWG,4.5 L,5-4	80009	195-3990-00
W1902	196-3223-00		LEAD, ELECTRICAL:22 AWG,3.75 L,9-N	80009	196-3223-00

*This Document is a complete Scan from the original
Tektronix manual*

*For enquiries about our complete
High quality line of technical Manuals in PDF*

mailto : Qservice@otenet.gr

**SEE
OTHER
SIDE**

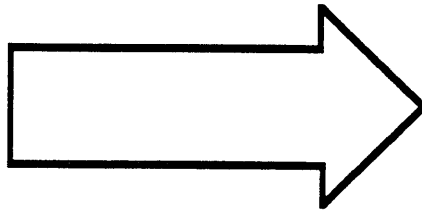

DIAGRAMS AND CIRCUIT BOARD ILLUSTRATIONS

Symbols

Graphic symbols and class designation letters are based on ANSI Standard Y32.2-1975.

Logic symbology is based on ANSI/IEEE 91-1984. Logic symbols depict the logic function performed and may differ from the manufacturer's data.

The overline on a signal name indicates that the signal performs its intended function when it is in the LO state.

Abbreviations are based on ANSI Y1.1-1972.

Other ANSI standards that are used in the preparation of diagrams by Tektronix, Inc., are:

Y14.15-1966 Drafting Practices.
 Y14.2M-1979 Line Conventions and Lettering.
 ANSI/IEEE 280-1985 Letter Symbols for Quantities Used in Electrical Science and Electrical Engineering.

American National Standards Institute
 1430 Broadway
 New York, New York 10018

Component Values

Electrical components shown on the diagrams are in the following units unless noted otherwise:

Capacitors Values one or greater are in picofarads (pF).
 Values less than one are in microfarads (μF).
 Resistors Ohms (Ω).

———— The information and special symbols below may appear in this manual. ————

Assembly Numbers and Grid Coordinates

Each assembly in the instrument is assigned an assembly number (e.g., A20). The assembly number appears on the circuit board outline on the diagram, in the title for the circuit board component location illustration, and in the lookup table for the schematic diagram and corresponding component locator illustration. The Replaceable Electrical Parts list is arranged by assemblies in numerical sequence; the components are listed by component number *(see following illustration for constructing a component number).

The schematic diagram and circuit board component location illustration have grids. A lookup table with the grid coordinates is provided for ease of locating the component. Only the components illustrated on the facing diagram are listed in the lookup table. When more than one schematic diagram is used to illustrate the circuitry on a circuit board, the circuit board illustration may only appear opposite the first diagram on which it was illustrated; the lookup table will list the diagram number of other diagrams that the circuitry of the circuit board appears on.

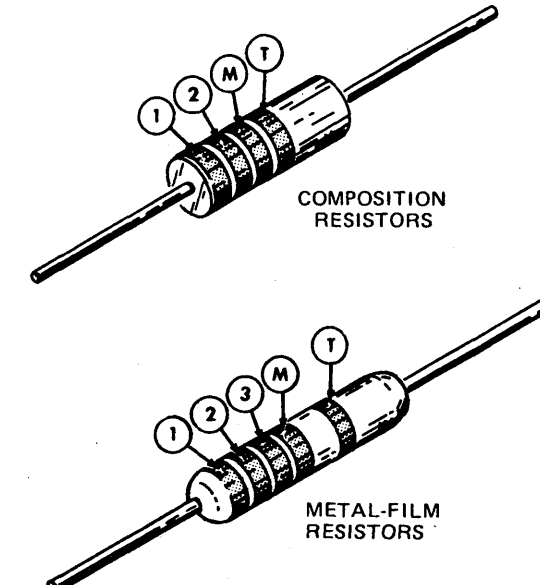

① ② and ③ — 1st, 2nd, and 3rd significant figures
 (M) — multiplier (T) — tolerance

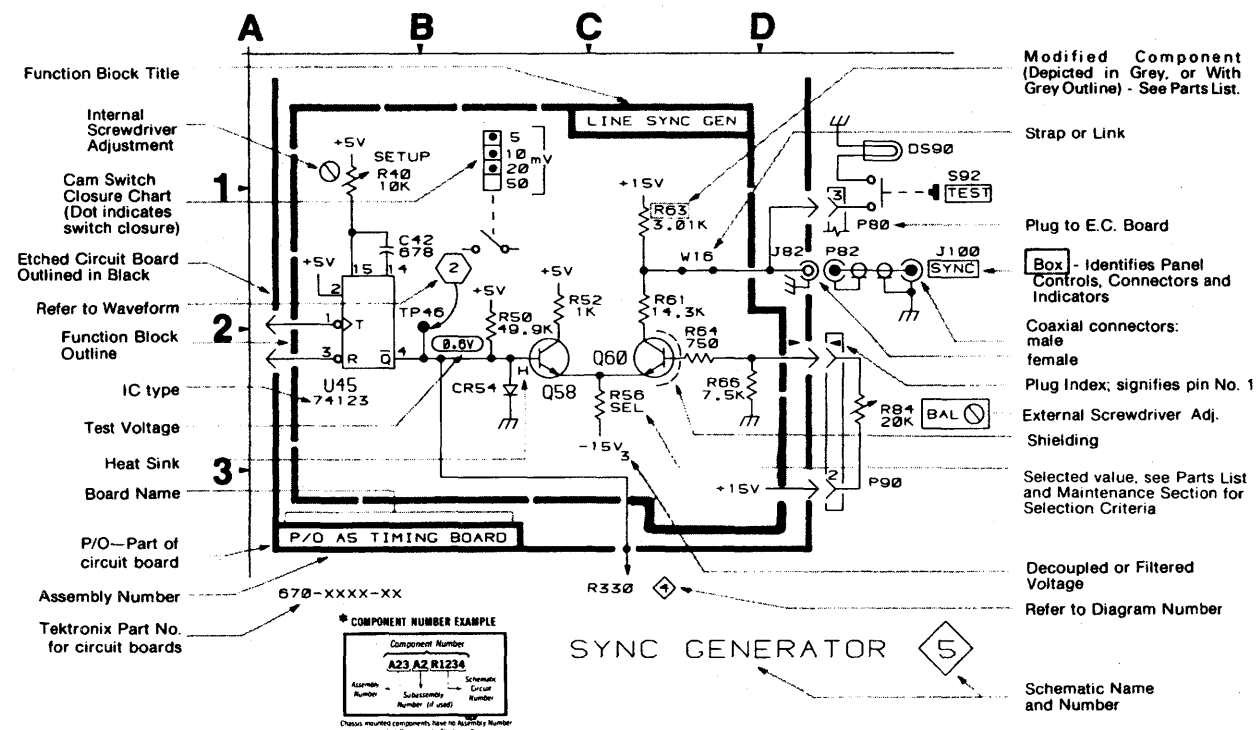

COLOR	SIGNIFICANT FIGURES	RESISTORS	
		MULTIPLIER	TOLERANCE
BLACK	0	1	---
BROWN	1	10	±1%
RED	2	10 ² or 100	±2%
ORANGE	3	10 ³ or 1 K	±3%
YELLOW	4	10 ⁴ or 10 K	±4%
GREEN	5	10 ⁵ or 100 K	±5%
BLUE	6	10 ⁶ or 1 M	±6%
VIOLET	7	---	±1/10%
GRAY	8	---	---
WHITE	9	---	---
GOLD	---	10 ⁻¹ or 0.1	±5%
SILVER	---	10 ⁻² or 0.01	±10%
NONE	---	---	±20%

(1861-20A)6557-87

Figure 9-1. Color codes for resistors.

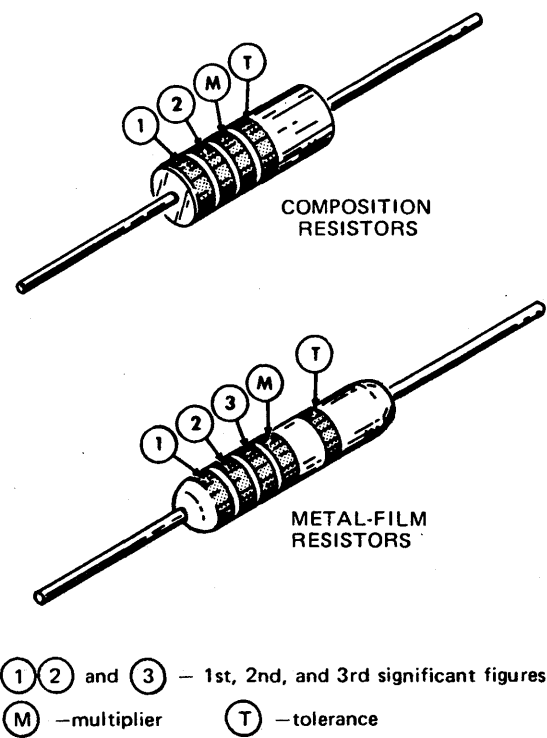

COLOR	SIGNIFICANT FIGURES	RESISTORS	
		MULTIPLIER	TOLERANCE
BLACK	0	1	---
BROWN	1	10	±1%
RED	2	10 ² or 100	±2%
ORANGE	3	10 ³ or 1 K	±3%
YELLOW	4	10 ⁴ or 10 K	±4%
GREEN	5	10 ⁵ or 100 K	±5%
BLUE	6	10 ⁶ or 1 M	±4%
VIOLET	7	---	±1/10%
GRAY	8	---	---
WHITE	9	---	---
GOLD	-	10 ⁻¹ or 0.1	±5%
SILVER	-	10 ⁻² or 0.01	±10%
NONE	-	---	±20%

(1861-20A)6557-87

Figure 9-1. Color codes for resistors.

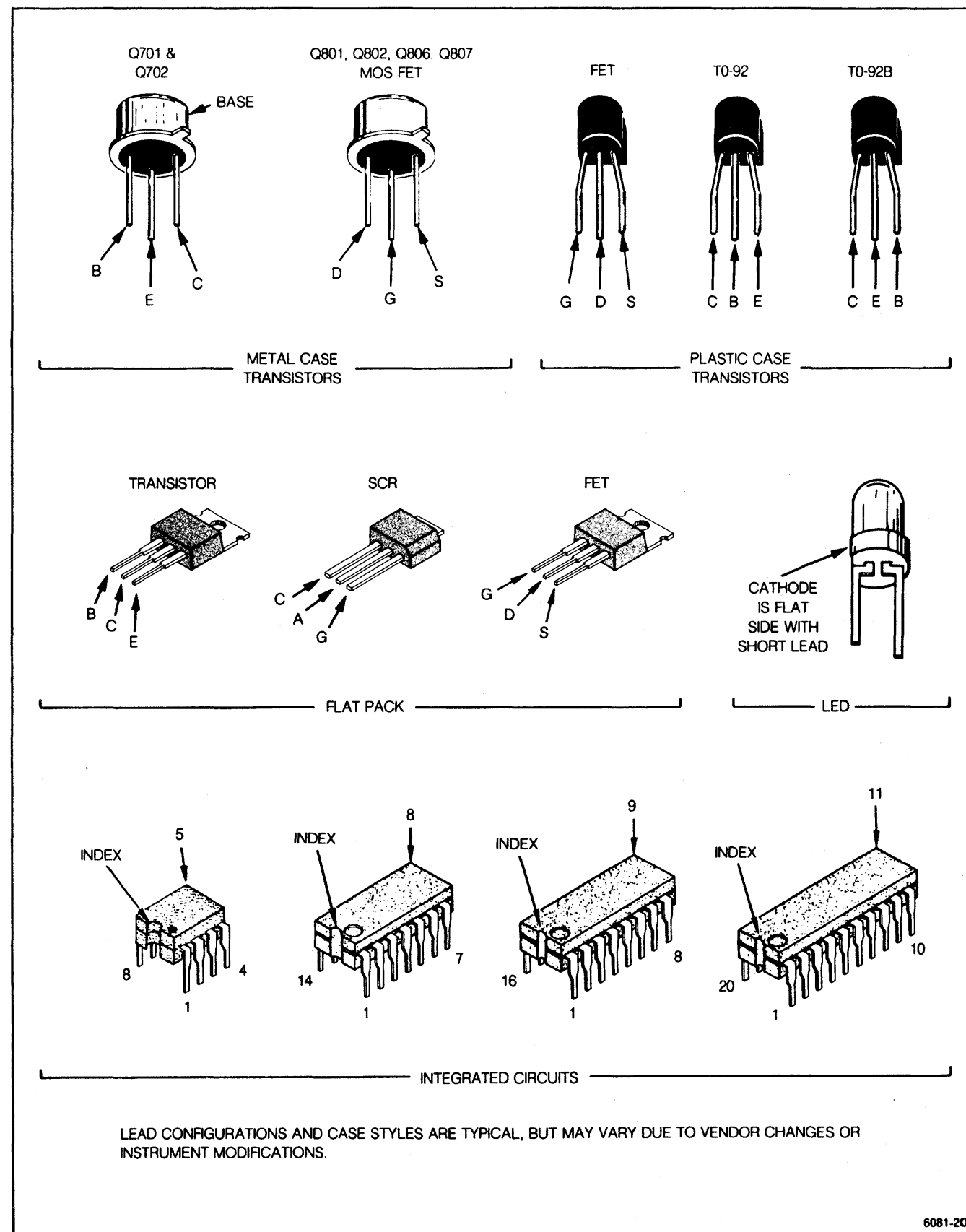

Figure 9-2. Semiconductor lead configurations.

1. Locate the Circuit Board Illustration.

- a. Identify the Assembly Number of the circuit board that the component is on by using the Circuit Board location illustration in this section or the mechanical parts exploded views at the rear of this manual.
- b. In the manual, locate the tabbed foldout page that corresponds with the Assembly Number of the circuit board. The circuit board assembly numbers and names are printed on the back side of the tabs (facing the rear of the manual).

To identify any component mounted on a circuit board and to locate that component in the schematic diagram.

2. Determine the Circuit Number and Schematic Diagram.

- a. Compare the circuit board with its illustration. Locate the component you are looking for by area and shape on the illustration to determine its Circuit Number.
- b. Scan the lookup table next to the Circuit Board illustration to find the Circuit Number of the component.
- c. Read the SCHEM NUMBER column next to the component's circuit number to find the Schematic Diagram number.

3. Locate the Component on the Schematic Diagram.

- a. Locate the tabbed page that corresponds to the Schematic Diagram number. Schematic diagram numbers and names are printed on the front side of the tabs (facing the front of the manual).
- b. Locate the Assembly Number in the Component Location lookup table next to the schematic diagram. Scan the CIRCUIT NUMBER column of that table to find the Circuit Number of the component you are looking for in the schematic.
- c. In the SCHEM LOCATION column next to the component, read the grid coordinates of the component in the schematic.
- d. Using the grid coordinates given, find the component in the schematic diagram.

- c. In the SCHEM LOCATION column next to the component, read the grid coordinates of the component in the schematic.
- d. Using the grid coordinates given, find the component in the schematic diagram.

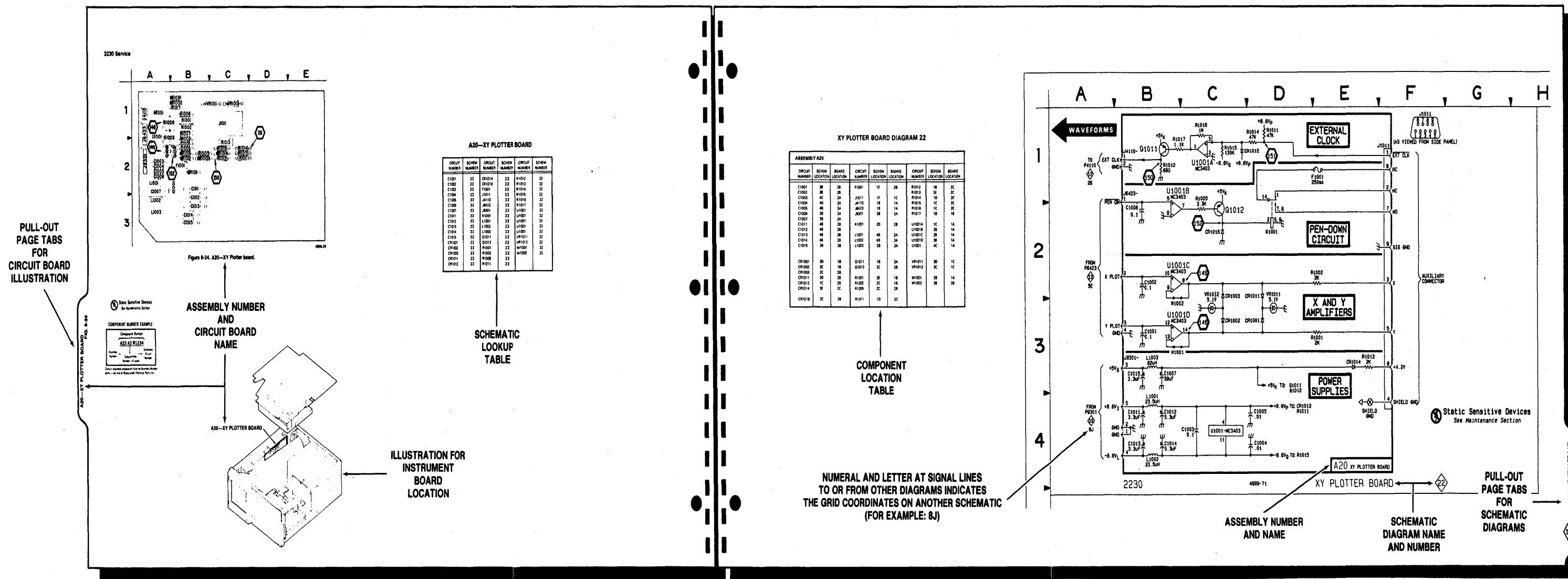

1. Determine the Circuit Board Illustration and Component Location.

- a. From the schematic diagram, determine the Assembly Number of the circuit board that the component is on. The Assembly Number and Name is boxed and located in a corner of the heavy line marking the circuit board outline in the schematic diagram.
- b. Find the Component Location table for the Assembly Number found on the schematic. Scan the CIRCUIT NUMBER column to find the Circuit Number of the component.
- c. Look in the BOARD LOCATION column next to the component number and read its circuit board grid coordinates.

To identify any component in a schematic diagram and to locate that component on its respective circuit board.

2. Locate the Component on the Circuit Board.

- a. In the manual, locate the tabbed page that corresponds to Assembly Number the component is on. Assembly numbers and names for circuit boards are on the back side of the tabs.
- b. Using the Circuit Number of the component and its given grid location, find the component in the Circuit Board illustration.

- c. From the small circuit board location illustration shown next to the circuit board, find the circuit board's location in the instrument.
- d. Find the circuit board in the instrument. Compare it with the circuit board illustration in the manual to locate the component on the circuit board itself.

Figure 9-3. Locating components on schematic diagrams and circuit board illustrations.

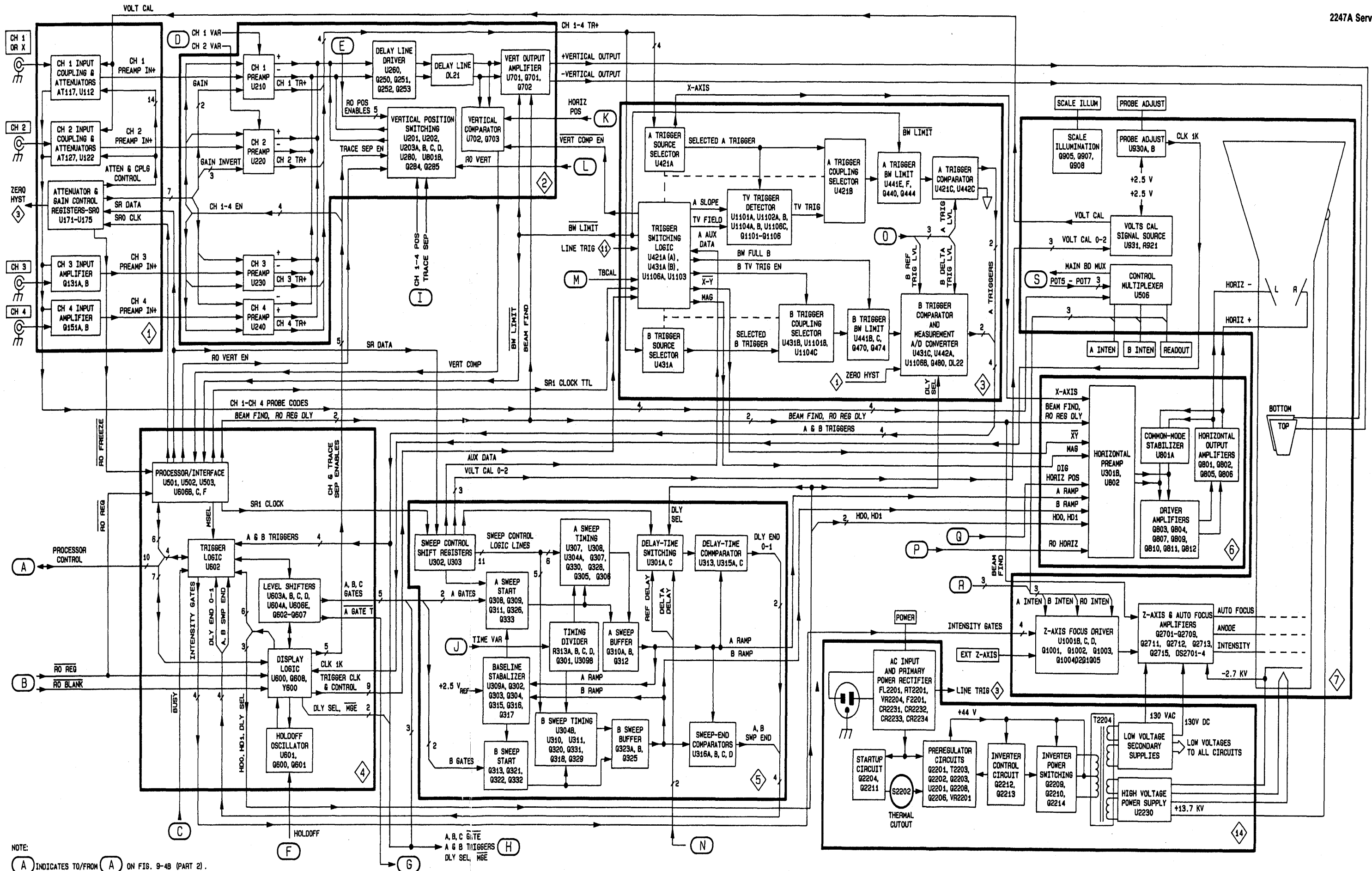

NOTE:
 (A) INDICATES TO/FROM (A) ON FIG. 9-4B (PART 2).

Figure 9-4a. Detailed block diagram—part 1.

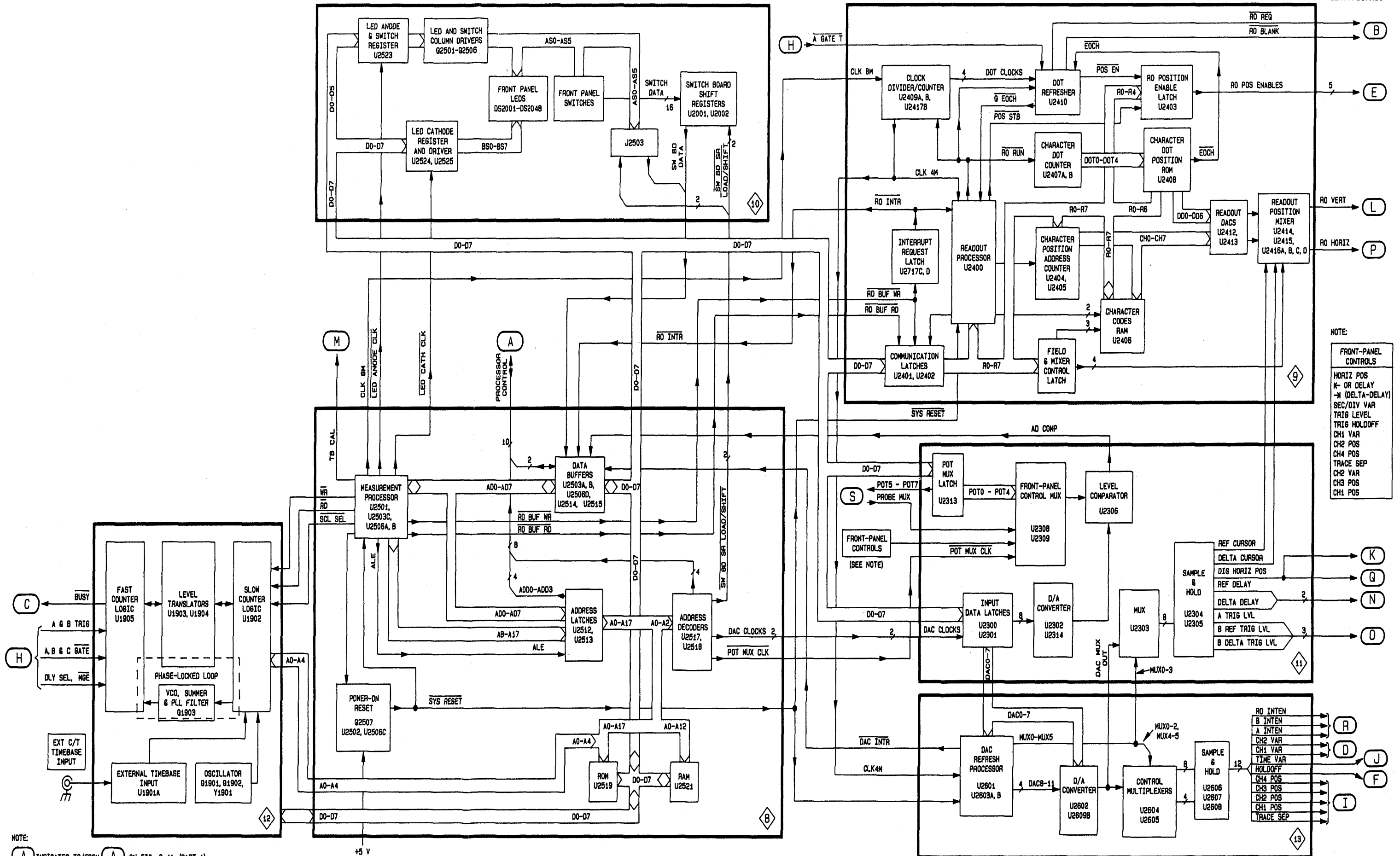

NOTE:
 (A) INDICATES TO/FROM (A) ON FIG. 9-4A (PART 1).

Figure 9-4b. Detailed block diagram—part 2.

NOTE:
 FRONT-PANEL CONTROLS
 HORIZ POS
 ← OR DELAY
 → (DELTA-DELAY)
 SEC/DIV VAR
 TRIG LEVEL
 TRIG HOLDOFF
 CH1 VAR
 CH2 POS
 CH4 POS
 TRACE SEP
 CH2 VAR
 CH3 POS
 CH1 POS

Table 9-1
SIGNAL LINE LOCATIONS

SIGNAL NAME	ORIGINATES ^a DIAG/CIR#(VIA)	GOES TO DIAG/CIR#(VIA)
A GATE	4/U603-11	5/VR302
A GATE	4/U603-14	5/VR301;12/U1905-37
A GATE T	4/Q604	9/U2410-9
A INTEN	13/U2607-8(R2610)	7/U1001-12
A INTEN GATE	4/U602-17	7/Q1001
A RAMP	5/Q312,Q328	6/U802-3
A SLOPE	4/U600-30	3/U421-8(R493)
A SWP END	5/U316-15(R378)	4/U602-8
A TRIG	3/U421-10(R411)	4/U602-7;12/U1905-34
A TRIG LVL	11/U2304-8	3/U421-24(R448)
AD COMP	11/U2306-7	8/U2515-12(R2511)
ADDR0	8/U2512-15(R2560)	4/U501-1,U602-38(R619),U600-4
ADDR1	8/U2512-6(R2561)	4/U501-2,U602-39(R618),U600-5
ADDR2	8/U2512-16(R2562)	4/U501-3,U600-6
ADDR3	8/U2512-5(R2563)	4/U502-10,U600-7
ATS 0	4/U600-31	3/U421-13(R490)
ATS 1	4/U600-32	3/U421-12(R491)
ATS 2	4/U600-33	3/U421-9(R492)
AUX DATA	5/U303-9	3/U1103-2(R1162)
B DELTA TRIG LVL	11/U2305-1	3/U1106-5
B GATE	4/U603-9	5/VR304
B GATE	4/U603-15	5/VR303;12/U1905-41
B INTEN	13/U2607-7(R2609)	7/U1001-5
B INTEN GATE	4/U602-18	7/Q1004
B RAMP	5/Q325,Q329	6/U802-5
B REF TRIG LVL	11/U2304-7	3/U1106-3
B SLOPE	4/U600-26	3/U431-8(R497)
B SWP END	5/U316-2(R380)	4/U602-37
B TRIG	3/U431-11(DL22+)	4/U602-34;12/U1905-39
B TRIG	3/U431-12(DL22-)	4/C612
BEAM FIND	4/U503-7	7/Q2706(R2705);2/U701-21;6/U802-14
BTS 0	4/U600-27	3/U431-13 (R494)
BTS 1	4/U600-28	3/U431-12(R495)
BTS 2	4/U600-29	3/U431-9(R496)
BUSY	12/U1905-18	4/U602-6
BW LIMIT	3/U1103-11	4/U502-4;2/U701-22;3/U441-11, U441-13
C GATE	4/U604-6	12/U1905-45
CH 1 EN	4/U600-39	2/U210-11(R213)
CH 1 POS	13/U2608-14(R2619)	2/U203-3
CH 1 PRB	1/R105	7/U506-15
CH 1 PREAMP 0	1/U172-4	2/U210-1(CR201)
CH 1 PREAMP 1	1/U171-11	2/U210-2(CR202)
CH 1 PREAMP IN +	1/U112-8	2/U210-7
CH 1 TR +	2/U210-20	3/U421-7,U431-7

Table 9-1 (cont)

SIGNAL NAME	ORIGINATES ^a DIAG/CIR#(VIA)	GOES TO DIAG/CIR#(VIA)
CH 1 VAR	13/U2606-1(R2612)	2/U210-10(R225)
CH 2 EN	4/U600-38	2/U220-11 (R223)
CH 2 INVERT	1/U173-6	2/U220-12
CH 2 POS	13/U2608-8(R2618)	2/U203-5
CH 2 PRB	1/R106,C121	7/U506-12
CH 2 PREAMP 0	1/U173-5	2/U220-1
CH 2 PREAMP 1	1/U173-4	2/U220-2
CH 2 PREAMP IN +	1/U122-8	2/U220-7
CH 2 TR +	2/U220-20	3/U421-5,U431-5
CH 2 VAR	13/U2607-14(R2611)	2/U220-10(R227)
CH 3 EN	4/U600-37	2/U230-11(R233)
CH 3 POS	13/U2608-7(R2617)	2/U203-10
CH 3 PRB	1/R107,C131	7/U506-1
CH 3 PREAMP 1	1/U173-7	2/U230-2
CH 3 PREAMP IN +	1/Q131A(R139),Q131B(R139)	2/U230-7
CH 3 TR +	2/U230-20	3/U421-3,U431-3
CH 4 EN	4/U600-36	2/U240-11(R243)
CH 4 POS	13/U2608-1(R2616)	2/U203-12
CH 4 PRB	1/R108,C151	7/U506-5
CH 4 PREAMP 1	1/U173-14	2/U240-2
CH 4 PREAMP IN +	1/Q151A(R159),Q151B(R159)	2/U240-7
CH 4 TR +	2/U240-20	3/U421-1,U431-1
CLK 1K	7/U930-7(R933,R934)	4/U600-2
CLK 4M	9/U2417-3	13/U2601-4
CLK 8M	8/U2501-56	9/U2409-1
DAC0	11/U2301-12	13/U2601-20,U2602-12
DAC1	11/U2301-9	13/U2601-21,U2602-11
DAC2	11/U2301-15	13/U2601-22,U2602-10
DAC3	11/U2301-6	13/U2601-23,U2602-9
DAC4	11/U2301-16	13/U2601-24,U2602-8
DAC5	11/U2301-5	13/U2601-25,U2602-7
DAC6	11/U2301-19	13/U2601-26,U2602-6
DAC7	11/U2301-2	13/U2601-27,U2602-5
DAC BUF WR	8/U2517-15	13/U2603-1
DAC BUF RD	13/U2601-18	11/U2301-1
DAC INTR	13/U2603-6	8/U2515-16(R2554)
DAC MUX OUT	13/U2602-19(U2609-7)	11/U2303-3
DAC MSB CLK	8/U2517-14	11/U2300-11
DATA BUS	8/U2514	9/U2401,U2402;10/U2523,U2524; 11/U2300,U2301,U2307,U2313
DELTA CURSOR	11/U2304-1	9/U2414-2,U2415-2
DELTA DELAY	11/U2305-7	5/U301-12(R330),U313-6(R330)
DIG HORIZ POS	11/U2305-14	6/U301-3(R369);2/U702-3(R722)
DLY END 0	5/U315-15(R388)	4/U602-36
DLY END 1	5/U315-2(R387)	4/U602-35
DLY SEL	4/U600-25	5/U301-11;3/U1106-9;12/U1905-47

Table 9-1 (cont)

SIGNAL NAME	ORIGINATES ^a DIAG/CIR#(VIA)	GOES TO DIAG/CIR#(VIA)
CH 1 VAR	13/U2606-1(R2612)	2/U210-10(R225)
CH 2 EN	4/U600-38	2/U220-11 (R223)
CH 2 INVERT	1/U173-6	2/U220-12
CH 2 POS	13/U2608-8(R2618)	2/U203-5
CH 2 PRB	1/R106,C121	7/U506-12
CH 2 PREAMP 0	1/U173-5	2/U220-1
CH 2 PREAMP 1	1/U173-4	2/U220-2
CH 2 PREAMP IN +	1/U122-8	2/U220-7
CH 2 TR +	2/U220-20	3/U421-5,U431-5
CH 2 VAR	13/U2607-14(R2611)	2/U220-10(R227)
CH 3 EN	4/U600-37	2/U230-11(R233)
CH 3 POS	13/U2608-7(R2617)	2/U203-10
CH 3 PRB	1/R107,C131	7/U506-1
CH 3 PREAMP 1	1/U173-7	2/U230-2
CH 3 PREAMP IN +	1/Q131A(R139),Q131B(R139)	2/U230-7
CH 3 TR +	2/U230-20	3/U421-3,U431-3
CH 4 EN	4/U600-36	2/U240-11(R243)
CH 4 POS	13/U2608-1(R2616)	2/U203-12
CH 4 PRB	1/R108,C151	7/U506-5
CH 4 PREAMP 1	1/U173-14	2/U240-2
CH 4 PREAMP IN +	1/Q151A(R159),Q151B(R159)	2/U240-7
CH 4 TR +	2/U240-20	3/U421-1,U431-1
CLK 1K	7/U930-7(R933,R934)	4/U600-2
CLK 4M	9/U2417-3	13/U2601-4
CLK 8M	8/U2501-56	9/U2409-1
DAC0	11/U2301-12	13/U2601-20,U2602-12
DAC1	11/U2301-9	13/U2601-21,U2602-11
DAC2	11/U2301-15	13/U2601-22,U2602-10
DAC3	11/U2301-6	13/U2601-23,U2602-9
DAC4	11/U2301-16	13/U2601-24,U2602-8
DAC5	11/U2301-5	13/U2601-25,U2602-7
DAC6	11/U2301-19	13/U2601-26,U2602-6
DAC7	11/U2301-2	13/U2601-27,U2602-5
DAC BUF WR	8/U2517-15	13/U2603-1
DAC BUF RD	13/U2601-18	11/U2301-1
DAC INTR	13/U2603-6	8/U2515-16(R2554)
DAC MUX OUT	13/U2602-19(U2609-7)	11/U2303-3
DAC MSB CLK	8/U2517-14	11/U2300-11
DATA BUS	8/U2514	9/U2401,U2402;10/U2523,U2524; 11/U2300,U2301,U2307,U2313
DELTA CURSOR	11/U2304-1	9/U2414-2,U2415-2
DELTA DELAY	11/U2305-7	5/U301-12(R330),U313-6(R330)
DIG HORIZ POS	11/U2305-14	6/U301-3(R369);2/U702-3(R722)
DLY END 0	5/U315-15(R388)	4/U602-36
DLY END 1	5/U315-2(R387)	4/U602-35
DLY SEL	4/U600-25	5/U301-11;3/U1106-9;12/U1905-47

Table 9-1 (cont)

SIGNAL NAME	ORIGINATES ^a DIAG/CIR#(VIA)	GOES TO DIAG/CIR#(VIA)
FLIC WR	8/U2518-11	4/U602-40(R647)
HD0	4/U600-24	6/U802-8
HD1	4/U600-23	6/U802-11
HOLD OFF	13/U2606-14(R2615)	4/Q600(R636)
+ HORIZONTAL OUTPUT	5/Q805(R819),Q806(R819)	7/V1-R
- HORIZONTAL OUTPUT	5/Q801(R802),Q802(R802)	7/V1-L
IZ INTEN GATE	4/U602-19	7/Q1003
LED ANODE CLK	8/U2501-27	10/U2523-11(R2528)
LED CATH CLK	8/U2501-25	10/U2524-11(R2529)
LINE TRIG	14/T2206	3/U1106-2
MAG	3/U1103-6	6/U802-6
MAIN BD MUX	7/U506-3(R503)	11/U2309-12(R2352)
MB CNTL WR	8/U2518-15(R2564)	4/U501-4
MB DATA	8/U2515-11(R2555)	4/U600-9,U602-12,U502-2
MB RETURN	4/U502-12	8/U2515-14(R2509)
MGE	4/U600-35	12/U1905-49
MUX0	13/U2601-12	11/U2303-11
MUX1	13/U2601-13	11/U2303-10
MUX2	13/U2601-14	11/U2303-9
MUX3	13/U2601-15	11/U2303-6
POT5	11/U2313-5	7/U506-11(R508)
POT6	11/U2313-19	7/U506-10(R510)
POT7	11/U2313-2	7/U506-9(R512)
POT MUX CLK	8/U2517-13	11/U2313-11
RD	8/U2501-62	12/U1902-19
REF CURSOR	11/U2304-14	9/U2414-5,U2415-5
REF DELAY	11/U2305-8	5/U301-13(R329)
RO BLANK	9/U2410-16(R2419)	4/U600-12
RO BUF RD	8/U2501-29(R2515)	9/U2402-1
RO BUF WR	8/U2501-28(R2516)	9/U2417-9,U2401-11
RO CH 1 POS EN	9/U2403-19	2/U202-10
RO CH 2 POS EN	9/U2403-2	2/U202-11
RO CH 3 POS EN	9/U2403-5	2/U201-9
RO CH 4 POS EN	9/U2403-6	2/U201-10
RO FREEZE	1/U173-11	4/U502-5,U503-3
RO HORIZ	9/U2416-8	6/U802-1
RO INTEN	13/U2607-1(R2608)	7/U1001-10
RO INTEN GATE	4/U602-20	7/Q1002
RO INTR	9/U2417-11	8/U2515-15(R2508)
RO REQ	9/U2410-14(R2420)	4/U503-2,U600-11

VOLTAGE/WAVEFORM SETUP CONDITIONS

WAVEFORMS

Test waveforms are shown on a page just before the schematic diagram to which they apply. Normal control settings for the test oscilloscope are given in the readouts shown in each waveform illustration. Unless otherwise indicated near the waveform, setup conditions for the oscilloscope under test are as follows:

1. Set up the 2247A front-panel controls as follows:

VERTICAL MODE	CH 1 (other channels off)
CH 1 COUPLING	DC
CH 1 VOLTS/DIV	0.1 V
VERTICAL POSITION	
Controls	12 o'clock
SCOPE BW	On
HORIZONTAL MODE	A
A/B SELECT	A
SEC/DIV	0.1 ms
Trigger LEVEL	12 o'clock
HOLDOFF	MIN (ccw)
SLOPE	↘
Trigger MODE	AUTO LEVEL
Trigger SOURCE	VERT
Trigger CPLG	DC
MEASUREMENTS	Off
MENU Displays	Off
A INTEN	10 o'clock
READOUT	12 o'clock
FOCUS	For well-defined display
SCALE ILLUM	Fully ccw

2. Connect the front panel PROBE ADJUST output to the CH 1 input connector.
3. For all waveforms, except those obtained from the low-voltage power supply, connect the test oscilloscope probe ground wire to the chassis. When obtaining waveforms from the power supply, first connect the power cord of the 2247A under test

through an isolation transformer, then connect probe ground wire to ground "P" (rear side of R2256). See Figure 9-12 to locate ground "P".

WARNING

To avoid electrical shock and instrument damage, always connect the power cord of the instrument under test through an isolation transformer when viewing waveforms or measuring voltages in the low-voltage power supply.

DC VOLTAGES

Dc voltages shown on the schematic diagrams are typical of a normally operating instrument. Voltages are referenced to chassis ground, except in the isolated portion of the low-voltage power supply where they are referenced to ground "P" (at R2256 as shown in Figure 9-12). Make sure that the DMM leads are floating (isolated from chassis ground) when measuring voltages in this section.

TEST EQUIPMENT

The following test equipment is recommended for obtaining waveforms and voltages from the 2247A Oscilloscope. Other similar equipment can also be used.

1. Test Oscilloscope with 10X probe(s) — TEKTRONIX 2246A or TEKTRONIX 2247A.
2. Digital Voltmeter — TEKTRONIX DM501A.
3. Power-Line Isolation Transformer — Tektronix Part No. 006-5953-00.

OTHER PARTS

CIRCUIT NUMBER	SCHEM NUMBER	SCHEM LOCATION	CIRCUIT NUMBER	SCHEM NUMBER	SCHEM LOCATION	CIRCUIT NUMBER	SCHEM NUMBER	SCHEM LOCATION
B25	14	6N	P25	14	6N	S2202	14	3E
FL2201	14	2A	P26	7	1L	V1	7	1M
J16	7	7A	P27	7	2M	W601	12	8B
J19	12	2B	P601	12	2B	W1902	12	8B
			P1901	12	8B			
			P1902	12				

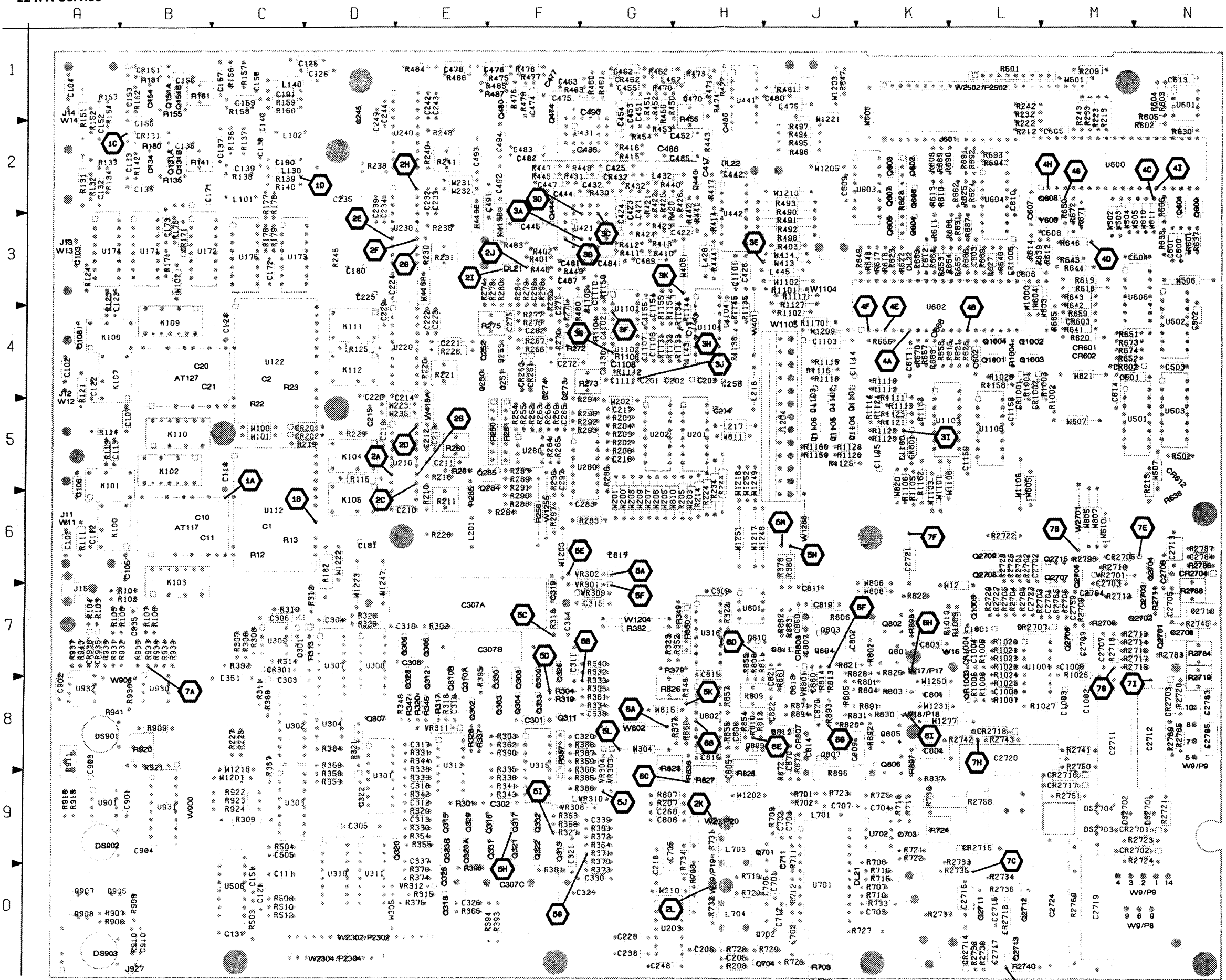

Static Sensitive Devices
See Maintenance Section

COMPONENT NUMBER EXAMPLE

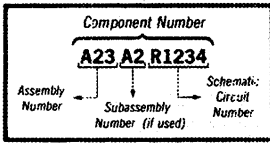

Chassis-mounted components have no Assembly Number prefix—see end of Replaceable Electrical Parts List

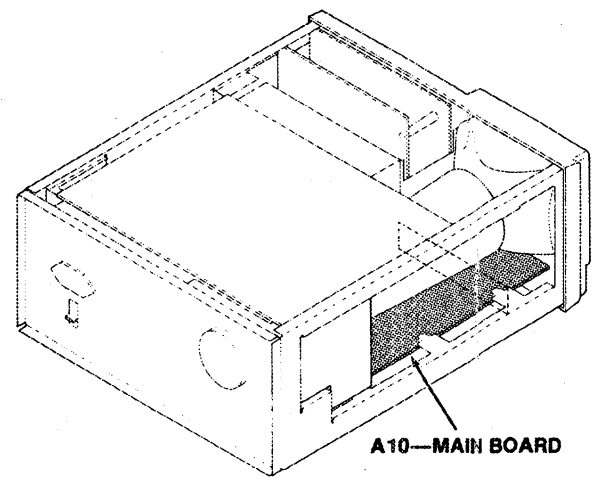

Figure 9-5. A10—Main board.

A10—MAIN BOARD

CIRCUIT NUMBER	SCHEM NUMBER	CIRCUIT NUMBER	SCHEM NUMBER	CIRCUIT NUMBER	SCHEM NUMBER	CIRCUIT NUMBER	SCHEM NUMBER	CIRCUIT NUMBER	SCHEM NUMBER	CIRCUIT NUMBER	SCHEM NUMBER
AT117	1	C235	15	C488	3	C1155	3	J14	1	Q328	5
AT127	1	C238	2	C489	3	C1158	15	J15	7	Q329	5
		C239	15	C490	2	C1159	15	J601	4	Q330	5
C1	1	C242	2	C491	2	C1160	15	J927	7	Q331	5
C2	1	C243	2	C492	2	C2701	15	J1204	15	Q332	5
C10	1	C244	15	C493	2	C2702	15			Q333	5
C11	1	C245	15	C494	2	C2703	7	K100	1	Q440	3
C20	1	C248	2	C495	3	C2704	7	K101	1	Q444	3
C21	1	C249	15	C496	3	C2705	7	K102	1	Q470	3
C101	1	C258	2	C501	15	C2706	7	K103	1	Q474	3
C102	1	C265	15	C502	15	C2707	7	K104	1	Q480	3
C103	1	C268	2	C503	15	C2708	7	K105	1	Q600	4
C104	1	C271	2	C505	15	C2709	15	K107	1	Q601	4
C105	1	C272	2	C600	4	C2710	7	K108	1	Q602	4
C106	1	C273	2	C601	4	C2711	7	K109	1	Q603	4
C107	1	C274	2	C602	4	C2712	7	K110	1	Q604	4
C108	1	C275	2	C603	4	C2713	7	K111	1	Q605	4
C111	1	C282	15	C604	15	C2715	7	K112	1	Q606	4
C112	1	C283	15	C605	15	C2716	7			Q607	4
C113	1	C297	15	C606	15	C2717	7	L101	15	Q608	4
C114	1	C298	15	C607	4	C2719	7	L102	15	Q701	2
C121	1	C301	5	C608	4	C2720	7	L130	1	Q702	2
C122	1	C302	5	C609	15	C2721	7	L140	1	Q703	2
C123	1	C303	5	C610	15	C2723	7	L201	15	Q704	2
C124	1	C304	15	C611	4	C2724	7	L216	15	Q801	6
C125	1	C305	5	C612	4	C2729	7	L217	15	Q802	6
C126	1	C306	5	C613	15	C2783	7	L426	3	Q803	6
C131	1	C307	5	C614	4	C2784	7	L432	3	Q804	6
C132	1	C308	5	C666	4	C2785	7	L445	15	Q805	6
C133	1	C309	15	C701	15	CR131	1	L462	3	Q806	6
C134	1	C310	5	C702	15	CR151	1	L475	15	Q807	6
C135	15	C311	5	C703	15	CR171	1	L701	2	Q809	6
C136	15	C312	5	C704	15	CR201	2	L702	2	Q810	6
C137	1	C313	5	C705	15	CR202	2	L703	2	Q811	6
C138	1	C314	5	C706	2	CR260	2	L704	2	Q812	6
C139	2	C315	5	C707	2	CR261	2			Q905	7
C140	15	C316	15	C708	15	CR301	5	P8	7	Q907	7
C151	1	C317	15	C711	2	CR432	3	P9	7	Q908	7
C152	1	C318	15	C712	2	CR462	3	P17	6	Q1001	7
C153	1	C319	6	C801	15	CR601	4	P18	6	Q1002	7
C154	1	C320	15	C802	6	CR602	4	P19	2	Q1003	7
C155	15	C321	5	C803	6	CR603	4	P20	2	Q1004	7
C156	15	C322	15	C804	6	CR612	4	P2302	7	Q1005	7
C157	1	C326	5	C805	6	CR801	6	P2302	15	Q1101	3
C158	1	C329	5	C806	15	CR802	6	P2304	7	Q1102	3
C159	2	C330	5	C807	6	CR803	6	P2502	4	Q1103	3
C171	15	C337	15	C808	6	CR807	6	P2502	15	Q1104	3
C172	15	C338	15	C809	6	CR935	7			Q1105	3
C173	1	C339	15	C811	2	CR936	7	Q131	1	Q1106	3
C180	15	C351	15	C814	6	CR1001	7	Q151	1	Q2701	7
C181	15	C421	3	C815	15	CR1002	7	Q171	1	Q2702	7
C190	1	C422	3	C816	15	CR1003	7	Q250	2	Q2703	7
C191	1	C423	3	C817	6	CR1004	7	Q251	2	Q2704	7
C201	2	C424	3	C818	15	CR1005	7	Q252	2	Q2705	7
C202	2	C425	3	C819	6	CR2701	7	Q253	2	Q2706	7
C203	2	C426	3	C820	6	CR2702	7	Q284	2	Q2707	7
C204	2	C432	3	C821	15	CR2703	7	Q285	2	Q2708	7
C205	15	C442	15	C822	15	CR2704	7	Q301	5	Q2709	7
C206	15	C444	3	C860	6	CR2705	7	Q302	5	Q2711	7
C210	2	C445	15	C870	6	CR2707	7	Q303	5	Q2712	7
C211	2	C447	3	C880	6	CR2713	7	Q304	5	Q2713	7
C212	2	C451	3	C901	15	CR2714	7	Q305	5	Q2715	7
C213	2	C452	3	C902	15	CR2715	7	Q306	5		
C214	15	C453	3	C903	15	CR2716	7	Q307	5	R12	1
C215	15	C454	3	C904	15	CR2717	7	Q308	5	R13	1
C216	15	C455	3	C910	7	CR2718	7	Q309	5	R22	1
C217	15	C462	3	C935	7	C1004	7	Q310	5	R23	1
C218	2	C463	3	C1001	7	C1005	15	DL21	2	R101	1
C219	15	C474	3	C1002	7	C1006	15	DL22	3	Q311	5
C220	2	C475	15	C1003	7	C1101	15	Q312	5	R102	1
C221	2	C476	3	C1004	7	C1102	15	Q313	5	R103	1
C222	2	C477	3	C1005	15	C1103	3	Q315	5	R104	1
C223	2	C478	3	C1104	15	C1104	15	Q316	5	R105	1
C224	15	C480	15	C1105	3	C1105	3	Q317	5	R106	1
C225	15	C481	15	C1106	3	C1106	3	Q318	5	R107	1
C228	2	C482	15	C1107	3	C1107	3	Q320	5	R108	1
C229	15	C483	3	C1110	3	C1110	3	Q321	5	R111	1
C232	2	C484	3	C1111	3	C1111	3	Q322	5	R113	1
C233	2	C485	3	C1114	3	C1114	3	J11	1	R114	1
C234	15	C486	3	C1130	3	C1130	3	J12	1	R115	2
		C487	3	C1154	3	C1154	3	J13	1	R121	1

MORE 

A10—MAIN BOARD (cont)

CIRCUIT NUMBER	SCHEM NUMBER	CIRCUIT NUMBER	SCHEM NUMBER	CIRCUIT NUMBER	SCHEM NUMBER	CIRCUIT NUMBER	SCHEM NUMBER	CIRCUIT NUMBER	SCHEM NUMBER	CIRCUIT NUMBER	SCHEM NUMBER
R123	1	R255	2	R341	5	R447	3	R641	4	R812	6
R124	1	R256	2	R342	5	R448	3	R642	4	R813	6
R125	2	R260	2	R343	5	R449	3	R643	4	R814	6
R131	1	R261	2	R344	5	R450	3	R644	4	R820	6
R132	1	R262	2	R345	15	R451	3	R645	4	R821	6
R133	1	R263	2	R346	5	R452	3	R646	4	R822	6
R134	1	R264	2	R347	5	R453	3	R647	4	R823	6
R135	1	R265	2	R348	5	R454	3	R648	4	R825	6
R136	1	R266	2	R349	5	R455	3	R649	4	R826	6
R137	1	R267	2	R350	5	R456	3	R650	4	R827	6
R138	2	R268	2	R352	5	R460	3	R651	4	R828	6
R139	1	R269	2	R353	6	R461	3	R652	4	R829	6
R140	2	R270	2	R354	5	R462	3	R653	4	R830	6
R141	1	R271	2	R355	5	R463	3	R654	4	R831	6
R142	1	R272	2	R356	5	R470	3	R655	4	R836	6
R151	1	R273	2	R357	5	R471	3	R656	4	R837	15
R152	1	R274	2	R358	6	R472	3	R657	4	R854	6
R153	1	R275	2	R359	5	R473	3	R658	4	R855	6
R154	1	R276	2	R360	5	R474	3	R659	4	R856	6
R155	1	R277	2	R361	5	R475	3	R662	4	R857	6
R156	1	R278	2	R362	5	R476	3	R663	4	R860	6
R157	1	R279	2	R363	5	R477	3	R664	4	R861	6
R158	2	R280	2	R364	5	R478	3	R665	4	R862	6
R159	1	R281	2	R365	5	R479	3	R666	4	R863	6
R160	2	R282	15	R366	5	R480	15	R669	4	R871	6
R161	1	R283	15	R367	5	R481	15	R670	4	R872	6
R162	1	R284	2	R369	6	R483	3	R671	4	R873	6
R171	1	R285	2	R370	5	R484	3	R672	4	R891	6
R175	1	R286	2	R371	5	R485	3	R673	4	R892	6
R176	1	R287	2	R372	5	R486	3	R674	4	R893	6
R177	1	R288	2	R373	5	R487	3	R686	4	R894	6
R178	1	R289	2	R374	15	R490	3	R687	4	R896	6
R179	1	R290	2	R375	5	R491	3	R688	4	R897	6
R180	1	R291	2	R376	5	R492	3	R689	4	R898	6
R181	1	R292	2	R377	5	R493	3	R690	4	R906	7
R182	15	R293	2	R378	5	R494	3	R691	4	R907	7
R201	2	R294	2	R379	5	R495	3	R692	4	R908	7
R202	2	R295	2	R380	5	R496	3	R693	4	R909	7
R203	2	R296	2	R381	5	R497	3	R694	4	R910	7
R204	2	R297	15	R382	5	R498	3	R701	15	R911	7
R205	2	R298	15	R383	5	R501	4	R702	2	R915	15
R206	2	R301	5	R384	5	R502	4	R703	2	R916	15
R207	2	R302	5	R385	5	R503	7	R706	2	R920	7
R208	15	R303	5	R386	5	R504	15	R707	2	R921	7
R209	2	R304	5	R387	5	R508	7	R708	2	R922	7
R210	2	R305	5	R388	5	R510	7	R709	15	R923	7
R211	2	R306	5	R390	15	R512	7	R710	2	R924	7
R212	2	R307	5	R392	15	R601	4	R711	2	R930	7
R213	2	R308	5	R393	5	R602	4	R712	2	R931	7
R214	2	R309	5	R394	5	R603	4	R715	2	R932	7
R215	2	R310	5	R395	5	R604	4	R716	2	R933	7
R218	2	R311	5	R396	5	R605	4	R717	2	R934	7
R219	2	R312	15	R401	3	R606	4	R718	2	R935	7
R220	2	R313	5	R402	3	R609	4	R719	2	R936	7
R221	2	R314	5	R403	3	R610	4	R720	2	R937	7
R222	2	R315	5	R410	3	R611	4	R721	2	R938	7
R223	2	R316	5	R411	3	R612	4	R722	2	R939	7
R224	2	R317	5	R412	3	R613	4	R723	15	R940	7
R225	2	R318	5	R413	3	R614	4	R724	2	R941	7
R226	15	R319	5	R414	3	R615	4	R725	2	R1001	7
R227	2	R320	5	R415	3	R616	4	R726	2	R1002	7
R228	2	R321	5	R416	3	R617	4	R727	2	R1003	7
R229	2	R322	5	R417	3	R618	4	R728	2	R1004	7
R230	2	R323	5	R420	3	R619	4	R729	2	R1005	7
R231	2	R325	5	R421	3	R620	4	R730	2	R1006	7
R232	2	R326	5	R422	3	R621	4	R731	2	R1007	7
R233	2	R327	5	R423	3	R622	4	R732	2	R1008	7
R234	2	R328	5	R424	3	R623	4	R733	15	R1009	7
R235	2	R329	5	R425	3	R624	4	R734	15	R1010	7
R238	2	R330	5	R426	3	R625	4	R801	6	R1020	7
R240	2	R331	5	R430	3	R626	4	R802	6	R1021	7
R241	2	R332	5	R431	3	R627	4	R803	6	R1022	7
R242	2	R333	5	R432	3	R628	4	R804	6	R1023	7
R243	2	R334	5	R440	3	R630	4	R805	6	R1024	7
R244	2	R335	5	R441	3	R631	4	R806	6	R1025	7
R245	15	R336	5	R442	3	R636	4	R807	6	R1026	15
R248	2	R337	5	R443	3	R637	4	R808	6	R1027	15
R250	2	R338	5	R444	3	R638	4	R809	6	R1028	7
R251	2	R339	15	R445	3	R639	4	R810	6	R1101	15
R254	2	R340	5	R446	3	R640	4	R811	6	R1102	15
								R811	6	R1103	3

A10—MAIN BOARD (cont)

CIRCUIT NUMBER	SCHEM NUMBER	CIRCUIT NUMBER	SCHEM NUMBER	CIRCUIT NUMBER	SCHEM NUMBER	CIRCUIT NUMBER	SCHEM NUMBER	CIRCUIT NUMBER	SCHEM NUMBER	CIRCUIT NUMBER	SCHEM NUMBER
R1104	3	R2715	7	U201	2	U503	4	VR801	6	W802	5
R1105	3	R2716	7	U201	15	U503	15	VR2701	7	W805	6
R1106	3	R2717	7	U202	2	U506	7			W806	6
R1108	15	R2718	7	U202	15	U506	15	W9	7	W807	6
R1110	3	R2719	7	U203	2	U600	4	W11	1	W808	6
R1111	3	R2720	7	U203	15	U600	15	W12	1	W810	6
R1112	3	R2721	7	U210	2	U601	4	W13	1	W811	6
R1113	3	R2722	7	U210	15	U601	15	W14	1	W815	2
R1114	3	R2723	7	U220	2	U602	4	W16	7	W820	6
R1115	3	R2724	7	U220	15	U602	15	W17	6	W821	6
R1116	3	R2726	7	U230	2	U603	4	W18	6	W900	15
R1117	3	R2727	7	U230	15	U603	15	W19	2	W906	7
R1118	3	R2728	7	U240	2	U604	4	W20	2	W1000	7
R1120	3	R2729	7	U240	15	U604	15	W100	1	W1101	3
R1121	3	R2733	7	U260	2	U606	4	W101	1	W1102	3
R1122	3	R2734	7	U260	15	U606	15	W102	1	W1103	3
R1123	3	R2735	7	U280	2	U701	2	W200	2	W1104	15
R1124	3	R2736	7	U301	5	U701	15	W201	2	W1105	15
R1125	3	R2737	7	U301	6	U702	2	W202	2	W1106	3
R1126	3	R2738	7	U301	15	U702	15	W203	2	W1108	3
R1127	3	R2739	7	U302	5	U801	2	W205	2	W1200	15
R1128	3	R2740	7	U302	15	U801	6	W206	2	W1201	15
R1131	3	R2741	7	U303	5	U801	15	W207	2	W1202	15
R1132	3	R2742	7	U303	15	U802	6	W208	2	W1203	15
R1133	3	R2743	7	U304	5	U802	15	W209	2	W1204	15
R1134	3	R2745	7	U304	15	U901	15	W210	2	W1205	15
R1135	3	R2750	7	U307	5	U930	7	W223	2	W1209	15
R1136	3	R2751	7	U307	15	U930	15	W231	2	W1210	15
R1142	3	R2758	7	U308	5	U931	7	W232	2	W1216	15
R1143	3	R2760	7	U308	15	U931	15	W235	15	W1217	15
R1144	3	R2765	7	U309	5	U932	15	W304	5	W1218	15
R1145	3	R2783	15	U309	15	U1001	7	W305	6	W1221	15
R1150	3	R2784	7	U310	5	U1001	15	W401	3	W1222	15
R1154	3	R2785	7	U310	15	U1101	3	W406	3	W1223	15
R1155	3	R2786	7	U311	5	U1101	15	W413	3	W1231	15
R1158	15	R2787	7	U311	15	U1102	3	W414	3	W1237	15
R1159	15	R2788	7	U313	5	U1102	15	W415	2	W1247	15
R1160	15	R2789	7	U315	5	U1103	3	W416	2	W1248	15
R1162	3	R2795	7	U315	15	U1103	15	W501	15	W1249	15
R1163	3	R2796	7	U316	5	U1104	3	W502	4	W1250	15
R1170	3			U316	15	U1104	15	W503	4	W1251	15
R2701	7	U112	1	U421	3	U1106	3	W504	4	W1252	15
R2702	7	U112	15	U421	15	U1106	15	W505	4	W1255	15
R2703	7	U122	1	U431	3			W506	4	W1277	15
R2704	7	U122	15	U431	15	VR301	5	W507	4	W1288	7
R2705	7	U171	1	U441	3	VR302	5	W510	4	W2302	7
R2706	7	U171	15	U441	15	VR303	5	W603	4	W2302	15
R2708	7	U172	1	U442	3	VR304	5	W604	4	W2304	7
R2709	7	U172	15	U442							

WAVEFORMS FOR DIAGRAM 1

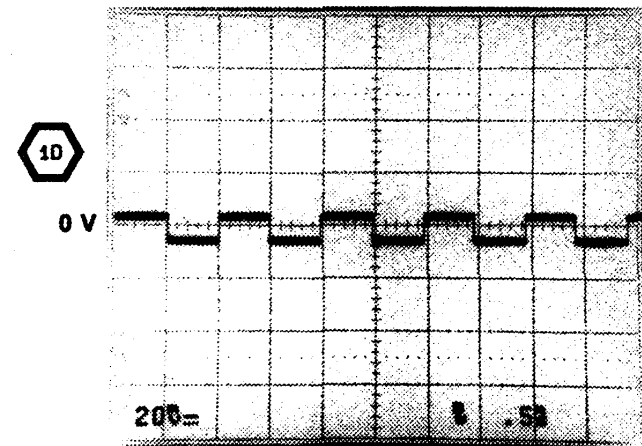
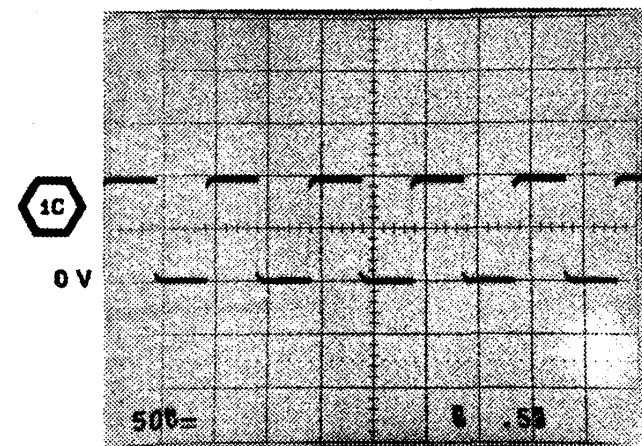
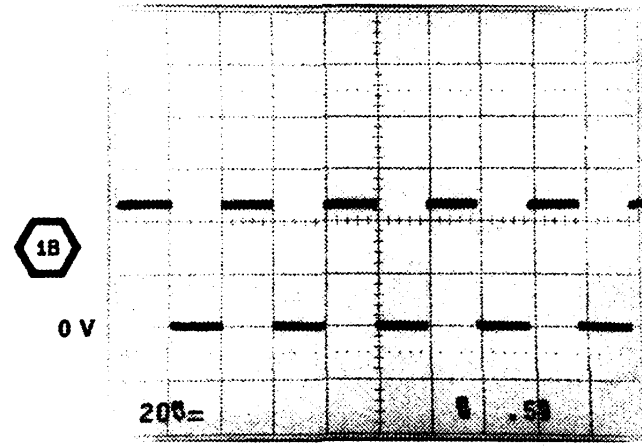
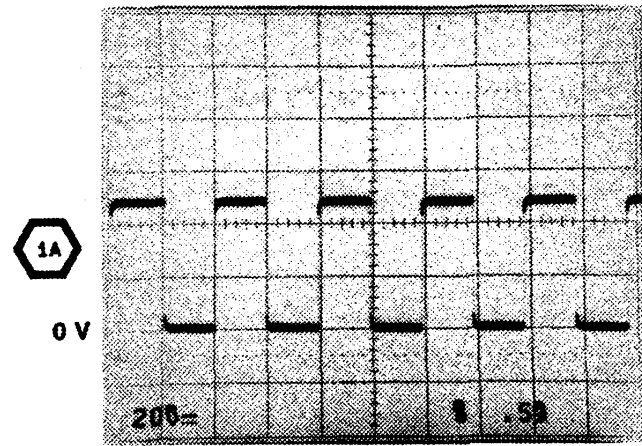

6555-39

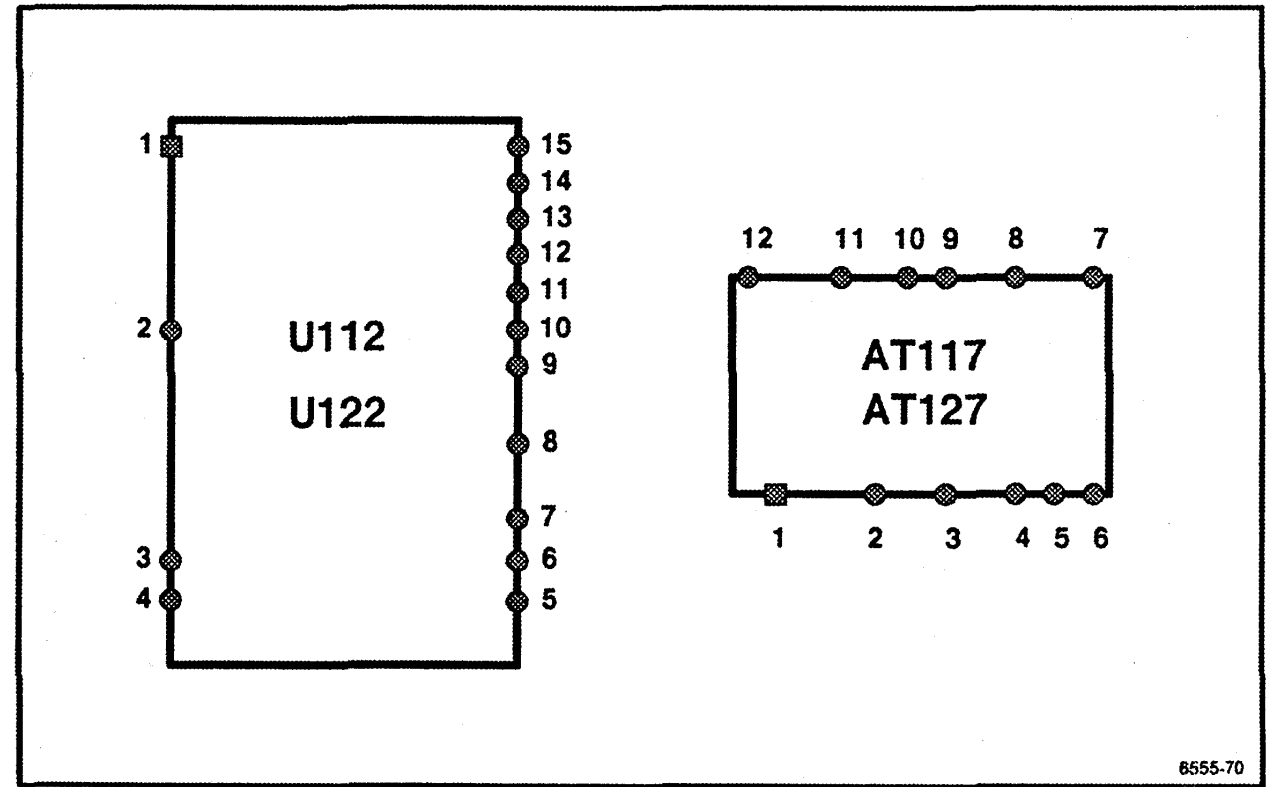

Figure 9-6. Hybrid pin identifiers.

A B C D E F G H J K L M N

1
2
3
4
5
6
7
8

← WAVEFORMS

CIRCUIT NUMBER	+15V	+7.5V	+5V	GND	-7.5V
U112		5, 14		1, 3, 6, 15	7, 13
U122		5, 14		1, 3, 6, 15	7, 13
U171				8	
U172				8	
U173			16	8	

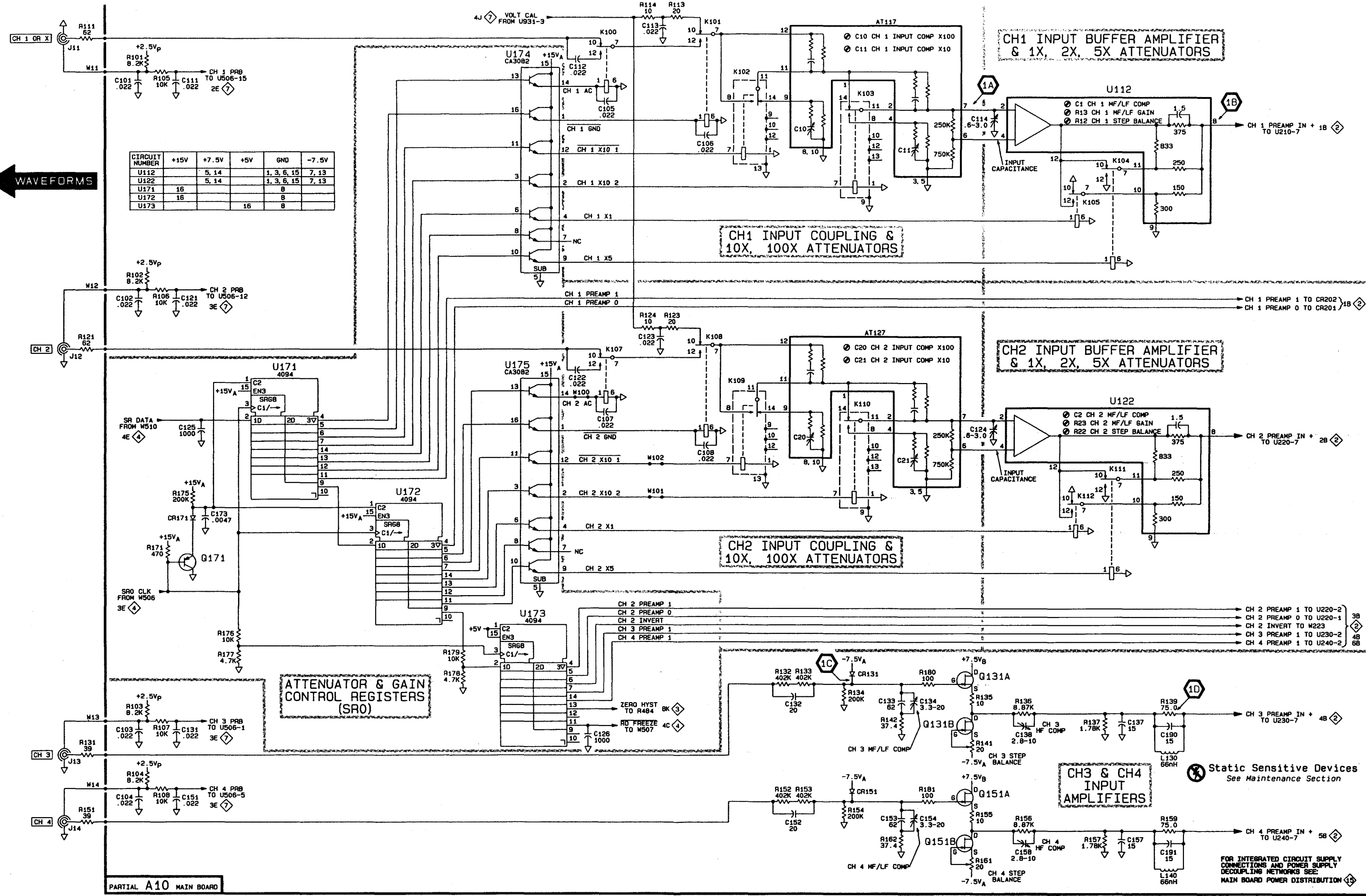

CH1 INPUT BUFFER AMPLIFIER & 1X, 2X, 5X ATTENUATORS

CH1 INPUT COUPLING & 10X, 100X ATTENUATORS

CH2 INPUT BUFFER AMPLIFIER & 1X, 2X, 5X ATTENUATORS

CH2 INPUT COUPLING & 10X, 100X ATTENUATORS

ATTENUATOR & GAIN CONTROL REGISTERS (SR0)

CH3 & CH4 INPUT AMPLIFIERS

⊗ Static Sensitive Devices
See Maintenance Section

FOR INTEGRATED CIRCUIT SUPPLY CONNECTIONS AND POWER SUPPLY DECOUPLING NETWORKS SEE: MAIN BOARD POWER DISTRIBUTION

VERTICAL INPUTS DIAGRAM 1

WAVEFORMS FOR DIAGRAM 2

ASSEMBLY A10											
CIRCUIT NUMBER	SCHEM LOCATION	BOARD LOCATION	CIRCUIT NUMBER	SCHEM LOCATION	BOARD LOCATION	CIRCUIT NUMBER	SCHEM LOCATION	BOARD LOCATION	CIRCUIT NUMBER	SCHEM LOCATION	BOARD LOCATION
AT117	1J	8B	C152	8H	2A	Q131A	7K	2B	R151	8A	1A
AT127	3H	4B	C153	8J	1B	Q131B	7J	2B	R152	8H	2A
			C154	8J	1B	Q151A	8K	1B	R153	8H	1A
C1	1K	6C	C157	8L	1C	Q151B	8J	1B	R154	8H	1A
C2	4K	4C	C158	8K	1C	Q171	5C	2B	R155	8J	1B
C10	2H	6C	C173	5C	3B				R156	8K	1C
C11	2J	6C	C190	7L	2C	R12	2K	6C	R157	8K	1C
C20	4H	4C	C191	8L	1C	R13	2K	6C	R159	8L	1C
C21	5J	4C				R22	4K	5C	R161	8J	1B
C101	1B	6A	CR131	6H	2B	R23	4K	4C	R162	8J	1B
C102	3B	4A	CR151	8H	1B	R101	1B	7B	R171	5B	3B
C103	7B	3A	CR171	5B	3B	R102	3B	7B	R175	5B	3B
C104	8B	1A				R103	7B	7A	R176	6C	3C
C105	1F	6B	J11	1A	6A	R104	7B	7A	R177	6C	2C
C106	2G	5A	J12	4A	4A	R105	1B	7A	R178	6E	2C
C107	4F	5B	J13	7A	3A	R106	3B	7B	R179	6E	3C
C108	5G	4A	J14	8A	1A	R107	7B	7B	R180	6J	2B
C111	1B	10C				R108	8B	7B	R181	8J	1B
C112	1F	6A	K100	1F	6A	R111	1A	6A			
C113	1F	5A	K101	1G	5A	R113	1G	5A	U112	1L	6C
C114	2J	5C	K102	1G	5B	R114	1F	5A	U122	4L	4C
C121	3B	10C	K103	1H	6B	R121	3A	4A	U171	4C	3B
C122	4F	4A	K104	2L	5D	R123	3G	4A	U172	5D	3B
C123	4F	4A	K105	2K	6D	R124	3F	3A	U173	6E	3C
C124	4J	4C	K107	4F	4A	R131	7A	2A	U174	1E	3A
C125	4B	1D	K108	4G	4A	R132	6H	2A	U175	4E	3C
C126	7F	1D	K109	4G	4B	R133	6H	2A			
C131	7B	10C	K110	4H	5B	R134	7H	2A	W11	1B	6A
C132	7H	2A	K111	5L	4D	R135	7J	2B	W12	3A	5A
C133	7J	2B	K112	5K	4D	R136	7K	2C	W13	7A	3A
C134	7J	2B				R137	7K	2C	W14	7A	2A
C137	7L	2C	L130	7L	2C	R139	7L	2C	W100	4F	5C
C138	7K	2C	L140	8L	1C	R141	7J	2B	W101	5G	5C
C151	8B	10C				R142	7J	2B	W102	5G	3B

Partial A10 also shown on diagrams 2, 3, 4, 5, 6, 7 and 15.

WAVEFORMS FOR DIAGRAM 2

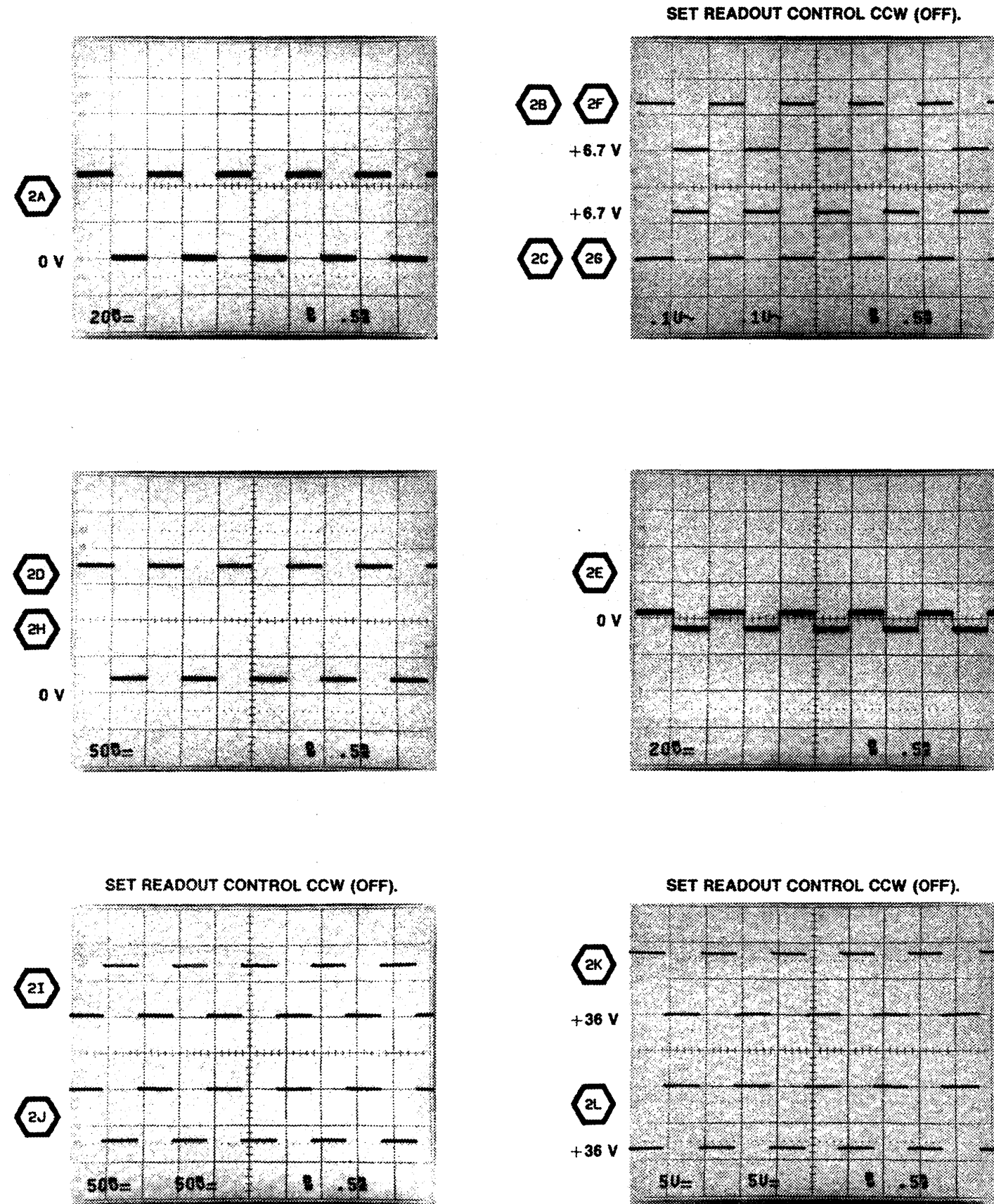

VERTICAL PREAMPS AND OUTPUT AMPLIFIER DIAGRAM 2

ASSEMBLY A10											
CIRCUIT NUMBER	SCHEM LOCATION	BOARD LOCATION	CIRCUIT NUMBER	SCHEM LOCATION	BOARD LOCATION	CIRCUIT NUMBER	SCHEM LOCATION	BOARD LOCATION	CIRCUIT NUMBER	SCHEM LOCATION	BOARD LOCATION
C139	4C	2C	Q251	4G	4F	R250C	5E	5F	R711	3L	9J
C159	5C	1C	Q252	3J	4E	R250D	3E	5F	R712	4L	10J
C201	7C	4G	Q253	4J	4F	R250E	2E	5F	R715	1L	10K
C202	7C	4H	Q284	6F	6E	R250F	1E	5F	R716	2L	10K
C203	7C	4H	Q285	6F	5E	R250G	5F	5F	R717	2M	9K
C204	8C	5H	Q701	3M	9H	R251A	4H	5F	R718	1M	9K
C210	1C	6E	Q702	4M	10H	R251B	5H	5F	R719	3M	10H
C211	2D	5E	Q703	2M	9K	R251C	5E	5F	R720	4M	10H
C212	1E	5E	Q704	6K	10H	R251D	4E	5F	R721	1L	9K
C213	2E	5E				R251E	2E	5F	R722	2L	9K
C218	6B	10G	R115	1D	5D	R251F	1E	5F	R724	4K	9K
C220	3C	4D	R125	2D	4D	R251G	5F	5F	R725	4K	9K
C221	3D	4E	R138	4C	2C	R254	3G	5F	R726	6K	10J
C222	3E	4E	R140	4D	2C	R255	3G	5F	R727	5K	10K
C223	3E	4E	R158	5C	1C	R256	2G	6F	R728	5K	10H
C228	7B	10G	R160	5D	1C	R260	7G	5E	R729	5K	10H
C232	4E	2E	R201	6E	5G	R261	7G	5E	R730	5K	9K
C233	5E	2E	R202	7E	5G	R262	3F	5F	R731	3M	9H
C238	7B	10G	R203	8E	5G	R263	4F	5F	R732	4M	10H
C242	5E	1E	R204	8E	5G	R264	3F	5F			
C243	6E	1E	R205	7D	6H	R265	4F	5F	U201	8D	5H
C248	8B	10G	R206	8E	5G	R266	2G	4F	U202	7D	5G
C258	8C	4H	R207	7C	9G	R267	2G	4F	U203A	6B	10G
C268	7D	9G	R209	7C	1M	R268	4J	5F	U203B	7B	10G
C271	3H	4F	R210	1E	6E	R269	2J	5F	U203C	7B	10G
C272	3H	4F	R211	1E	6E	R270	3J	4F	U203D	8B	10G
C273	3H	4F	R212	2C	2L	R271	4H	4F	U210	1D	5E
C274	3H	4F	R213	2C	1M	R272	3H	4F	U220	2D	4E
C275	4G	4F	R214	2C	6H	R273	3H	4G	U230	3D	3E
C491	2E	2E	R215	7C	5N	R274	3J	3E	U240	5D	2E
C492	3E	2F	R218	2C	5E	R275	3G	4E	U260	2F	5F
C493	4E	2E	R219	1C	5D	R276	4G	4F	U280	8F	5G
C494	6E	2F	R220	2E	4E	R277	3G	4F	U701	2L	10J
C706	3L	10H	R221	2E	4E	R278	3J	3F	U702	1M	9K
C707	6L	9J	R222	3C	2L	R279	4J	3F	U801B	8B	7H
C711	3L	9J	R223	3C	1M	R280	3J	3F			
C712	4L	10J	R224	3C	6H	R281	4J	3F	W19	4M	10H
C811	8B	7J	R225	1C	8C	R284	6E	6F	W20	3M	9H
			R227	2C	8C	R285	6G	6E	W200	3C	6G
CR201	2C	5D	R228	3C	4E	R286	7F	5G	W201	2C	6G
CR202	1C	5D	R229	1C	5D	R287	7F	5F	W202	7E	5G
CR260	3J	4F	R230	4E	3E	R288	7G	6F	W203	7D	6H
CR261	4J	4F	R231	4E	3E	R289	6G	5F	W205	7B	6G
			R232	5C	1L	R290	7F	6F	W206	6B	6G
DL21	3K	3F	R233	5C	1M	R291	7F	5F	W207	7B	6G
DL21	3K	9J	R234	4C	5H	R292	8E	5G	W208	8B	6G
			R235	5D	3E	R293	8F	5G	W209	8C	6G
L701	5L	9J	R238	5C	2D	R294	8G	5G	W210	8B	10G
L702	6L	10J	R240	5E	2E	R295	8G	5G	W223	3C	5E
L703	3M	9H	R241	5E	2E	R296	7F	5F	W231	4E	2E
L704	4M	10H	R242	6C	1L	R702	5K	9J	W232	4E	2E
			R243	6C	1M	R703	5K	10J	W415A	1E	5E
P19	4N	10H	R244	6C	5H	R706	3K	9K	W415B	1E	3F
P20	3N	9H	R248	6D	2E	R707	4K	10K	W416A	3E	3E
			R250A	2H	5F	R708	3M	10H	W416B	3E	3E
Q250	3G	4E	R250B	3H	5F	R710	1L	10K	W815	8B	8G

Partial A10 also shown on diagrams 1, 3, 4, 5, 6, 7 and 15.

A B C D E F G H J K L M N

1
2
3
4
5
6
7
8

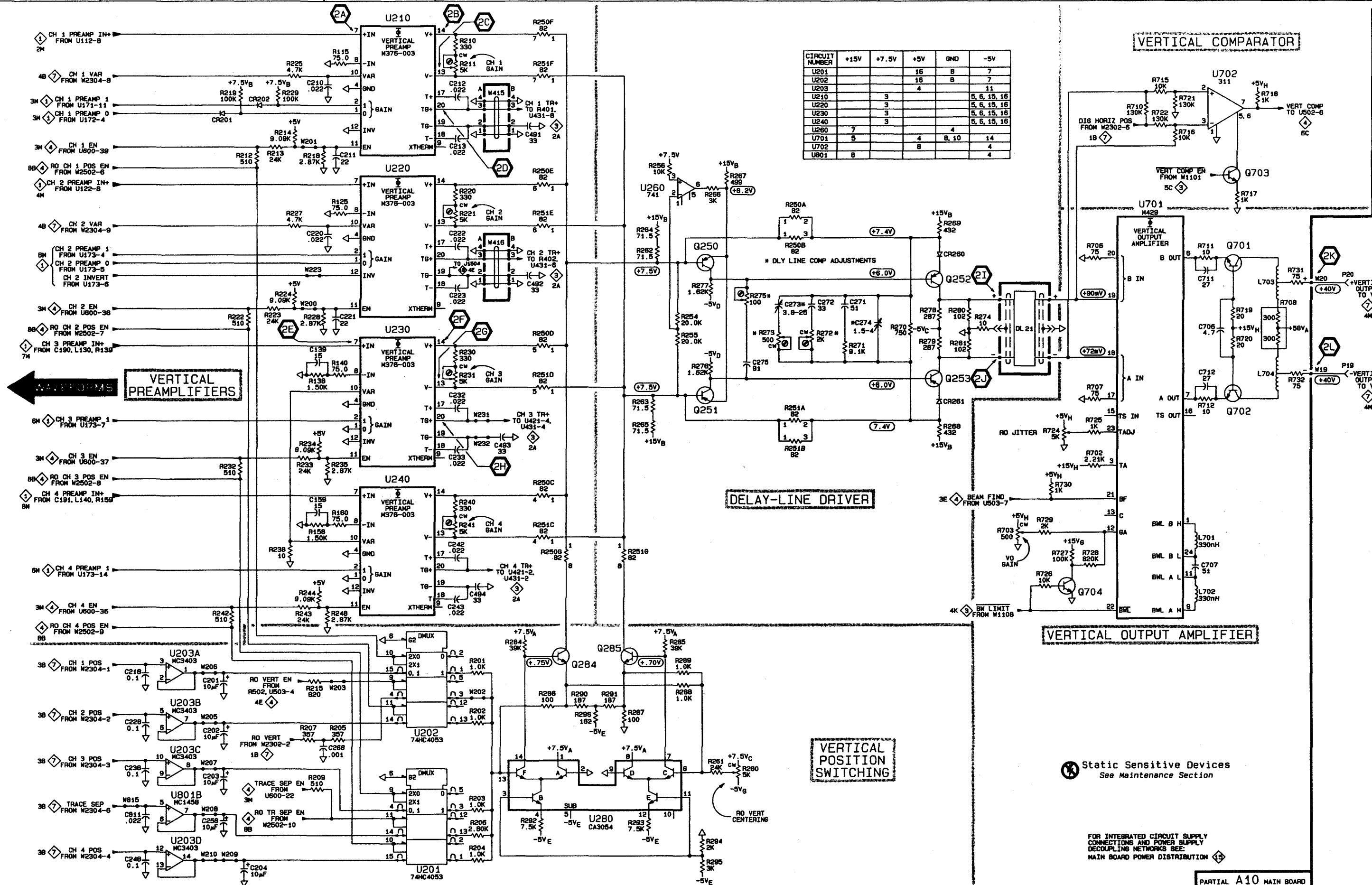

CIRCUIT NUMBER	+15V	+7.5V	+5V	GND	-5V
U201			16	8	7
U202			16	8	7
U203			4		11
U210	3			5, 6, 15, 16	
U220	3			5, 6, 15, 16	
U230	3			5, 6, 15, 16	
U240	3			5, 6, 15, 16	
U260	7		4	4	
U701	5		4	8, 10	14
U702			8		4
U801	8				

VERTICAL PREAMPLIFIERS

DELAY-LINE DRIVER

VERTICAL POSITION SWITCHING

VERTICAL OUTPUT AMPLIFIER

VERTICAL COMPARATOR

⊗ Static Sensitive Devices
See Maintenance Section

FOR INTEGRATED CIRCUIT SUPPLY CONNECTIONS AND POWER SUPPLY DECOUPLING NETWORKS SEE MAIN BOARD POWER DISTRIBUTION

PARTIAL A10 MAIN BOARD

WAVEFORMS FOR DIAGRAM 3

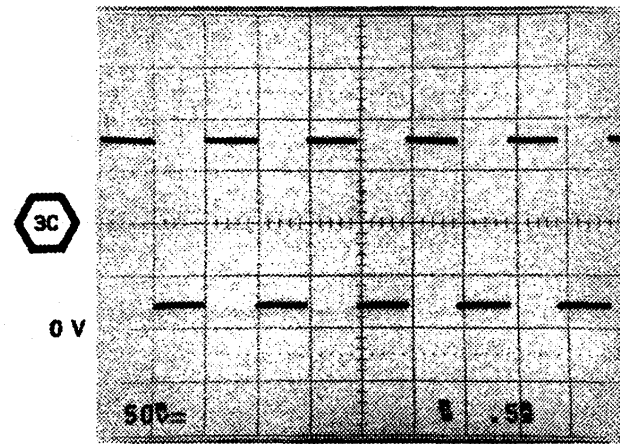
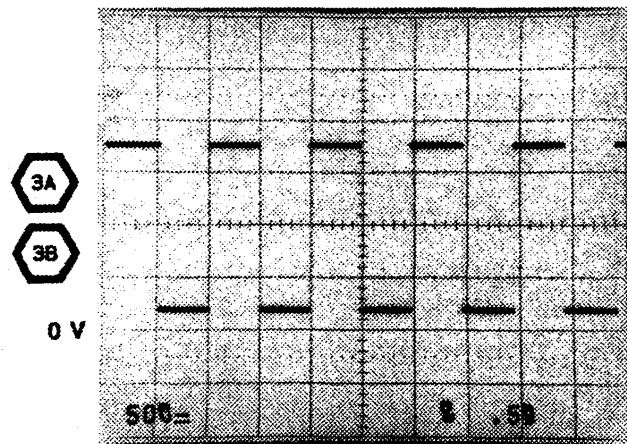

CONNECT 4-DIVISION COMPOSITE VIDEO SIGNAL.
SET SLOPE TO \searrow (NEGATIVE-GOING) FOR
BOTH 2247A AND TEST OSCILLOSCOPE.

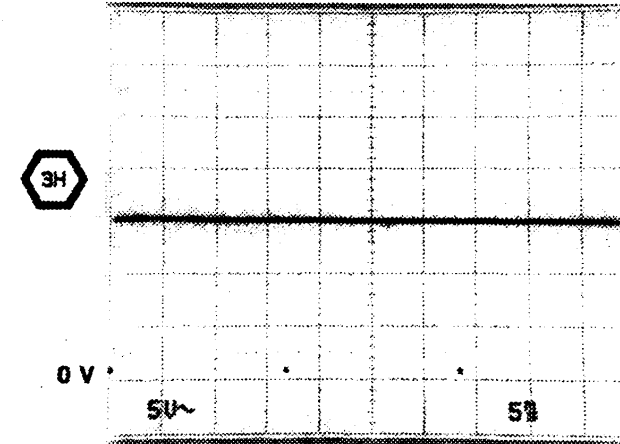

CONNECT 4-DIVISION COMPOSITE
VIDEO SIGNAL. SET TRIGGER MODE
TO TV FIELD.

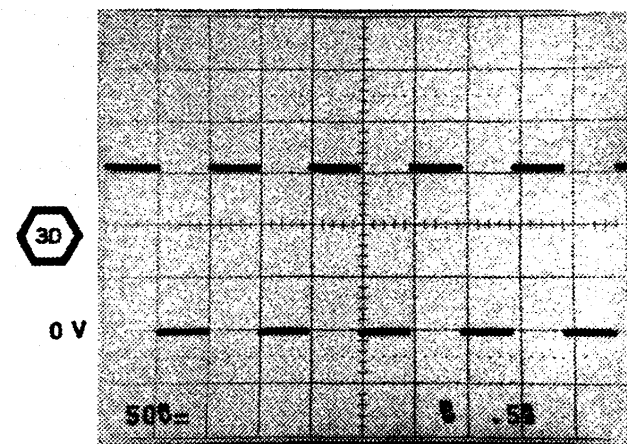
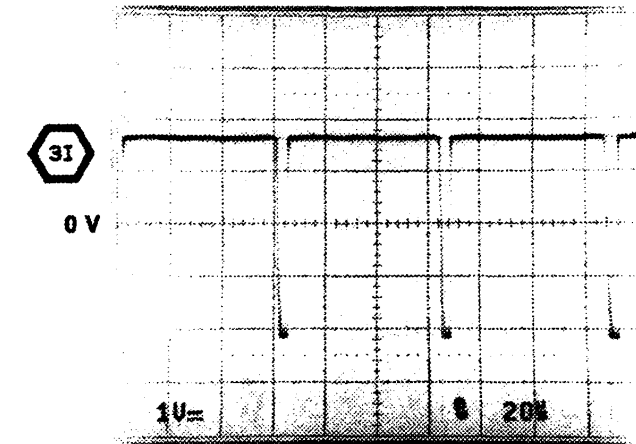

SET HORIZONTAL MODE TO ALT.

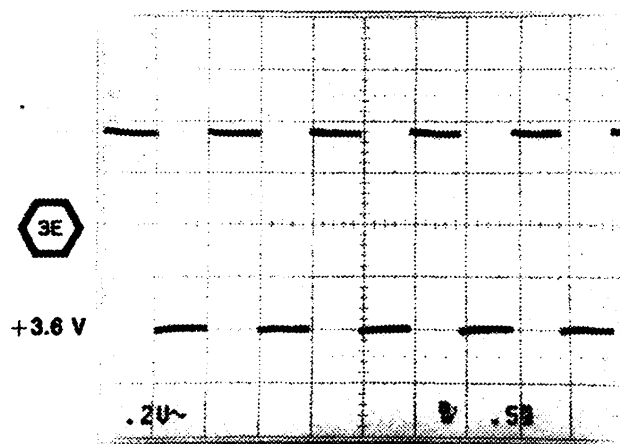

SET SLOPE TO \searrow (NEGATIVE-GOING) FOR
BOTH 2247A AND TEST OSCILLOSCOPE.

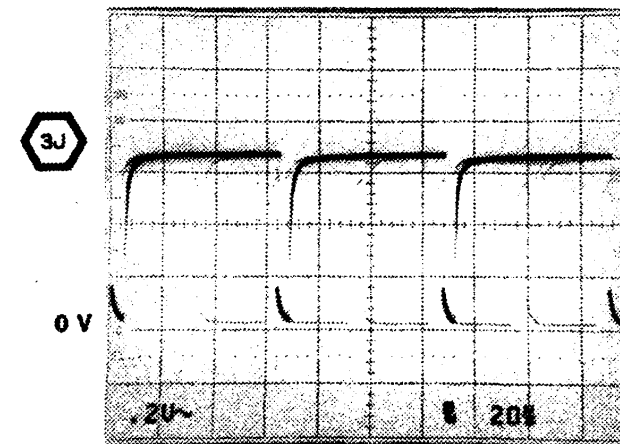

CONNECT 4-DIVISION COMPOSITE VIDEO SIGNAL.
SET TRIGGER MODE TO TV FIELD.
SET SLOPE TO \searrow (NEGATIVE-GOING) FOR
BOTH 2247A AND TEST OSCILLOSCOPE.

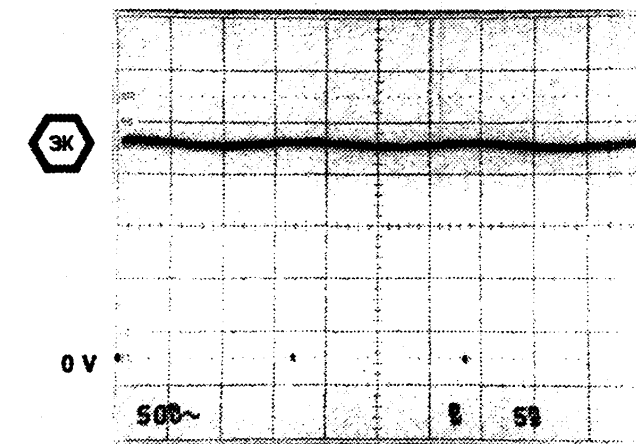

CONNECT 4-DIVISION COMPOSITE
VIDEO SIGNAL. SET TRIGGER MODE
TO TV FIELD.

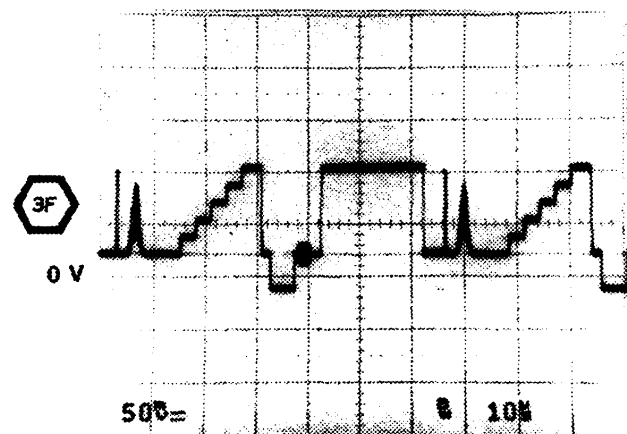

CONNECT 4-DIVISION COMPOSITE
VIDEO SIGNAL. SET TRIGGER MODE
TO TV FIELD.

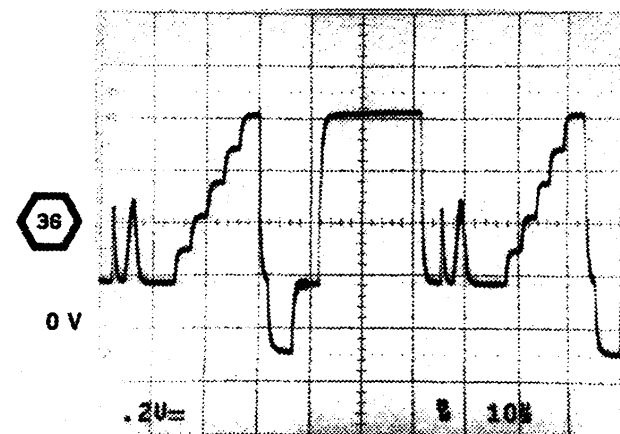

DIAGNOSTIC EXERCISE TIME REF AT 5 μ s

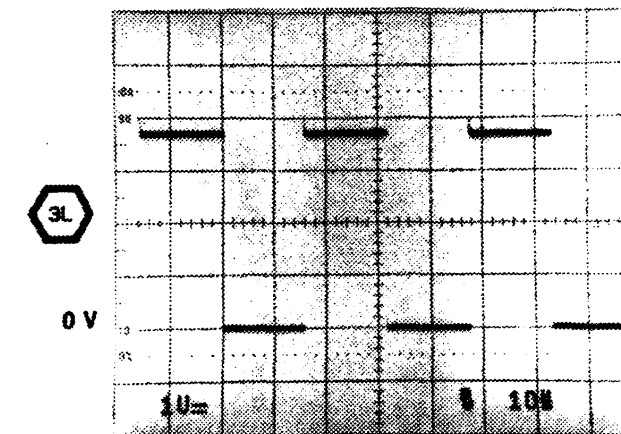

MORE \rightarrow

A AND B TRIGGER SYSTEM DIAGRAM 3

ASSEMBLY A10											
CIRCUIT NUMBER	SCHEM LOCATION	BOARD LOCATION	CIRCUIT NUMBER	SCHEM LOCATION	BOARD LOCATION	CIRCUIT NUMBER	SCHEM LOCATION	BOARD LOCATION	CIRCUIT NUMBER	SCHEM LOCATION	BOARD LOCATION
C417*	6M	2H	Q444	2L	2F	R463	6L	1F	R1136	4F	4H
C421	1H	2G	Q470	5K	1H	R470	6L	1G	R1142	3G	4G
C422	2H	3H	Q474	7K	1F	R471	5K	1H	R1143	4G	4H
C423	2H	2G	Q480	8L	1F	R472	5K	1H	R1144	3H	4H
C424	2H	3G	Q1101	5E	5J	R473	6K	1H	R1145	3H	4H
C425	2J	2G	Q1102	4E	5J	R474	6K	1H	R1150	2D	3G
C426	2D	3H	Q1103	5F	5J	R475	8K	1F	R1154	6F	4G
C432	1L	2G	Q1104	3E	5J	R476	8L	1F	R1155	6F	4G
C444	2L	2F	Q1105	3E	5J	R477	8L	1F	R1162	5A	5K
C447	3L	2F	Q1106	3F	5J	R478	7L	1F	R1163	5A	5K
C451	6G	1G				R479	7L	1F	R1170	3A	4J
C452	7H	2H	R401	2C	3F	R483	3B	3F			
C453	8G	1G	R402	2C	3F	R484	8K	1E	U421A	1C	3F
C454	7G	1G	R403	3L	3J	R485	8L	1F	U421B	1K	3F
C455	6H	1G	R410	1M	3G	R486	8L	1E	U421C	1L	3F
C462	6L	1G	R411	1M	3G	R487	8L	1F	U431A	7D	2F
C463	6L	1F	R412	2M	3G	R490	3B	2J	U431B	6J	2F
C474	6K	1F	R413	2M	3G	R491	4B	3J	U431C	6L	2F
C476	7K	1F	R414	6M	3H	R492	4B	3J	U441A	4K	1H
C477	7L	1F	R415	6L	2G	R493	4B	2J	U441B	5K	1H
C478	8K	1E	R416	6L	2G	R494	7B	2J	U441C	7K	1H
C483	3B	2F	R417	6M	2H	R495	7B	2J	U441D	4K	1H
C484	4B	3G	R420	2E	2G	R496	8B	2J	U441E	2K	1H
C485*	8B	2H	R421	1H	2G	R497	8B	2J	U441F	1K	1H
C486*	8B	2G	R422	2H	2G	R498	3B	3J	U442A	6M	2H
C487	3B	3F	R423	2H	3G	R1103	3D	3G	U442B	4K	2H
C488*	8b	2H	R424	2H	3G	R1104	3D	4G	U442C	1M	2H
C489	4B	3G	R425	2H	2G	R1105	8J	5K	U1101A	2E	4G
C490*	7B	2G	R426	2D	2H	R1106	8J	5K	U1101B	6G	4G
C496*	8B	2G	R430	2K	2G	R1110	5E	4K	U1102A	3G	4G
C1103	3A	4J	R431	1K	2F	R1111	4E	5K	U1102B	3H	4G
C1105	3E	5K	R432	2L	2G	R1112	4E	4K	U1103	5B	5K
C1106	3H	4G	R440	1L	2G	R1113	4E	5K	U1104A	3J	4H
C1107	3H	4G	R441	1L	2H	R1114	4F	5K	U1104B	4G	4H
C1110	3D	3G	R442	1K	2H	R1115	4F	4J	U1104C	6H	4H
C1111	3H	4G	R443	1K	2H	R1116	5F	4J	U1106A	2B	5L
C1114	5E	4J	R444	2K	3H	R1117	4F	3J	U1106B	8J	5L
C1130	4G	4G	R445	2L	2F	R1118	5F	4J	U1106C	4J	5L
C1143*	4H	4H	R446	2M	3F	R1120	3E	5K			
C1154	6F	4G	R447	3L	2F	R1121	4E	5K	W401	2D	4H
C1155	6G	4G	R448	3L	2F	R1122	3E	5K	W406	3J	3H
			R449	2M	3F	R1123	4E	5K	W413	1M	3J
CR432	1K	2G	R450	6E	1G	R1124	4F	5K	W414	2M	3J
CR462	6K	1G	R451	7G	1G	R1125	3F	5J	W1101	5C	5K
			R452	7G	1G	R1126	3F	5J	W1102	3D	3J
DL22	6M	2K	R453	8H	2G	R1127	4F	3J	W1103	6C	5K
DL22	6M	2H	R454	7H	2G	R1128	3F	5J	W1106	8J	5L
			R455	8D	1H	R1131	3G	4G	W1108	3K	5K
L426	2D	3H	R456	6F	1G	R1132	3H	4G			
L432	2L	2G	R460	6K	1G	R1133	3H	4H			
L462	6K	1G	R461	6K	1G	R1134	3J	4H			
			R462	6L	1G	R1135	4F	4H			
Q440	1L	2H									

Partial A10 also shown on diagrams 1, 2, 4, 5, 6, 7 and 15.

***See Parts List for serial number ranges.**

← WAVEFORMS

1
2
3
4
5
6
7
8

A TRIGGER SOURCE SELECTOR

A TRIGGER COUPLING SELECTOR

A TRIGGER COMPARATOR

A TRIGGER BW LIMIT

B TRIGGER SOURCE SELECTOR

TV TRIGGER DETECTOR

B TRIGGER BW LIMIT

B TRIGGER COMPARATOR & MEASUREMENT A/D CONVERTER

CIRCUIT NUMBER	+7.5V	+5V	GND	-5V	-7.5V
U421	21, 22, 23	27, 28	7		
U431	21, 22, 23	27, 28	7		
U441	14	7			
U442	1, 18	8			
U1101	8			4	
U1102	8			4	
U1103	16	8			7
U1104	16	8			7
U1106	16	8			7

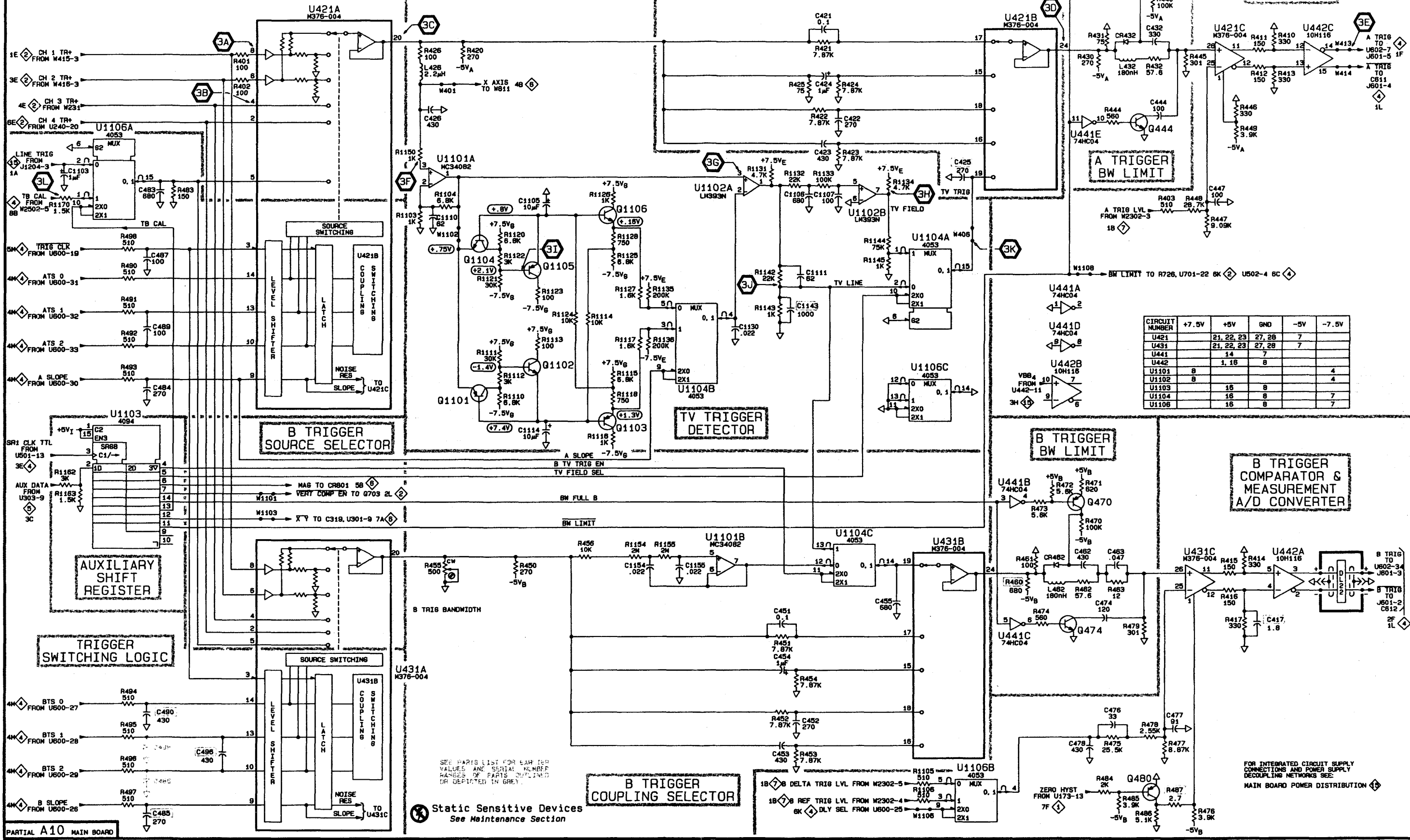

FOR INTEGRATED CIRCUIT SUPPLY CONNECTIONS AND POWER SUPPLY DECOUPLING NETWORKS SEE MAIN BOARD POWER DISTRIBUTION

WAVEFORMS FOR DIAGRAM 4

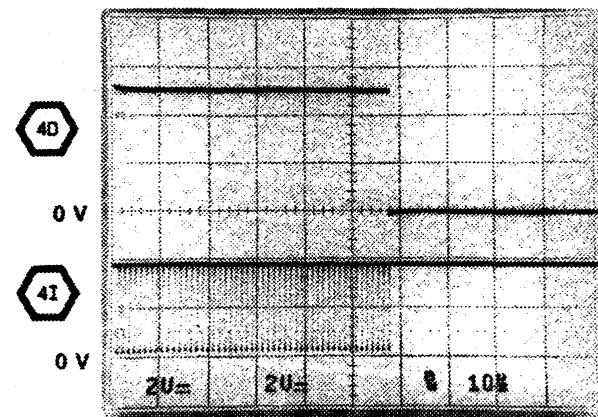
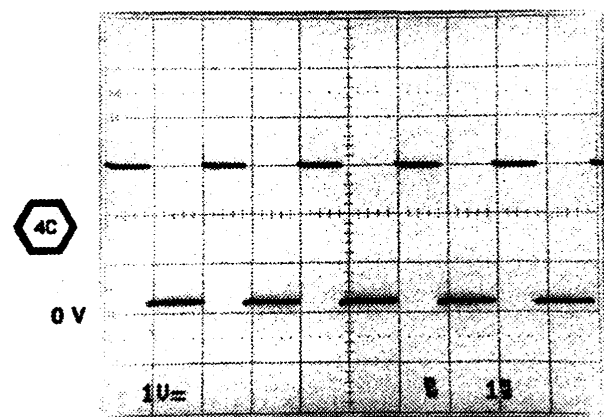
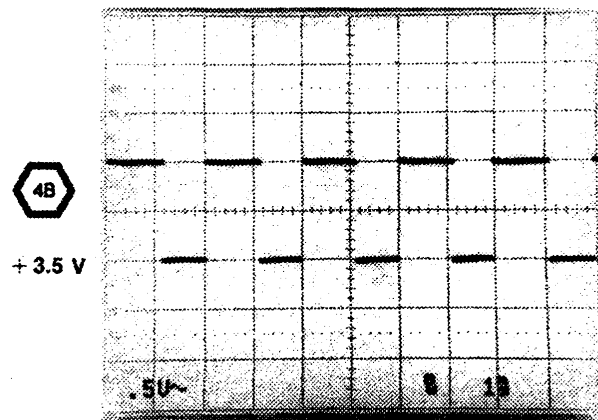
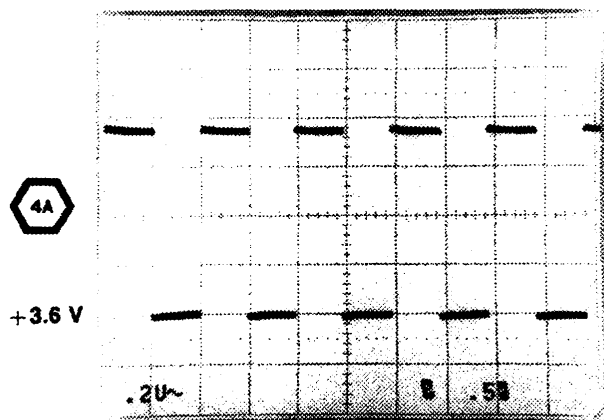

SET A & B SEC/DIV TO 0.1 ms, READOUT CONTROL CCW (OFF), AND HORIZONTAL MODE TO ALT.

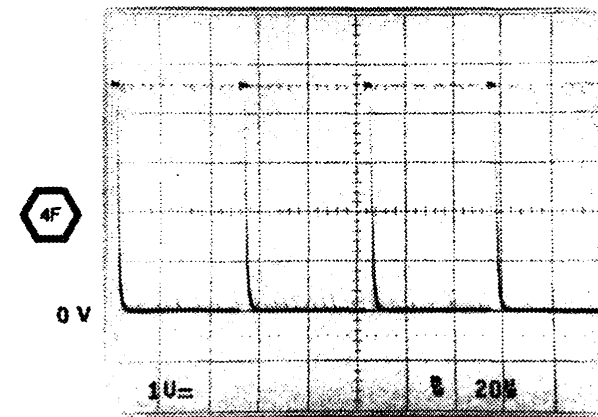
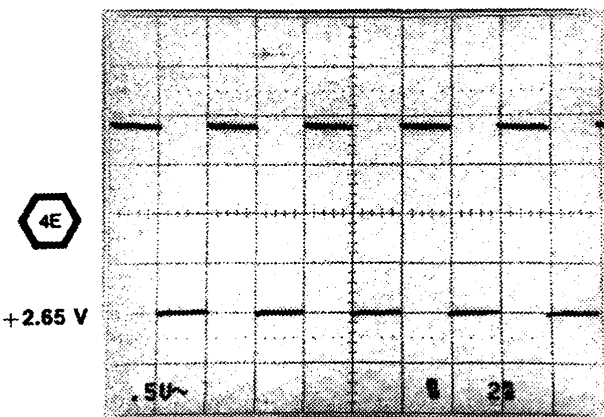

WAVEFORMS FOR DIAGRAM 4 (cont)

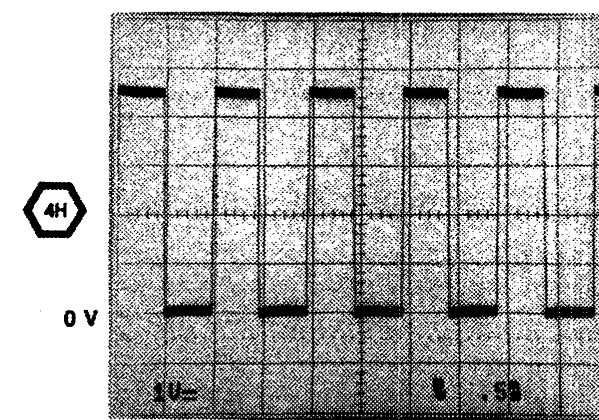
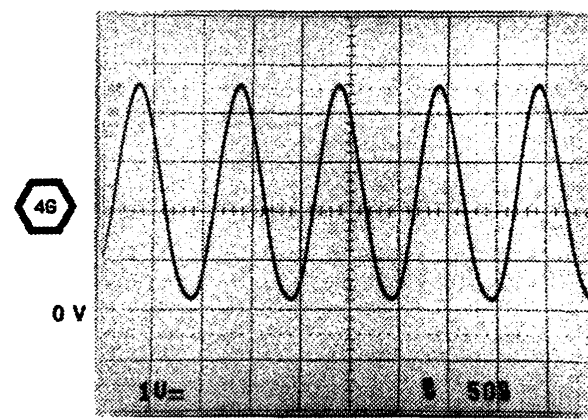

SET SEC/DIV TO 20 μ s. WAVEFORM VARIES WITH SETTING OF TRIGGER HOLDOFF CONTROL.

DISPLAY AND TRIGGER LOGIC AND PROCESSOR INTERFACE DIAGRAM 4

ASSEMBLY A10											
CIRCUIT NUMBER	SCHEM LOCATION	BOARD LOCATION	CIRCUIT NUMBER	SCHEM LOCATION	BOARD LOCATION	CIRCUIT NUMBER	SCHEM LOCATION	BOARD LOCATION	CIRCUIT NUMBER	SCHEM LOCATION	BOARD LOCATION
C600	8J	3N	R604	7K	1N	R647	5F	1J	U502	5D	4N
C601	8J	3N	R605	8L	1N	R648	5F	3K	U503	3D	5N
C602	1G	4L	R606	8J	2N	R649	5F	3K	U600	3L	2M
C603	1G	3L	R609	3K	2K	R650	6K	2M	U601	8K	1N
C607	6J	2L	R610	3K	2K	R651	2L	4M	U602	1G	3K
C608	6K	3M	R611	2K	3K	R652	5E	4M	U603A	3H	2K
C611	1L	4K	R612	2K	3M	R653	4F	3K	U603B	3H	2K
C612	1L	3K	R613	3J	2K	R654	4F	3K	U603C	1H	2K
C614	5D	4M	R614	3J	3L	R655	4F	3L	U603D	2H	2K
C666*	5J	4K	R615	5F	4K	R656	5H	4K	U604A	4J	2L
			R616	6F	3K	R657	4J	4K	U604B	2H	2L
CR601	2M	4M	R617	6F	3K	R658	5H	4K	U604C	8F	2L
CR602	2M	4M	R618	6F	3M	R659	5J	4M	U606A	5D	3M
CR603	5J	4M	R619	6F	3M	R662	4K	2L	U606B	3E	3M
CR612	8H	5N	R620	5F	4M	R663	6H	3K	U606C	4E	3M
			R621	5F	4L	R664	6J	3K	U606D	4E	3M
J601	1M	2K	R622	6F	3K	R665	5H	4M	U606E	2L	3M
			R623	6F	3K	R666	5J	4K	U606F	3E	3M
P2502	2M	1L	R624	4J	2L	R669	3H	3L			
P2502	4A	1L	R625	4J	2L	R670	4J	4K	W502	4C	3M
			R626	1G	4L	R671	6K	3M	W503	7C	3M
Q600	8J	2N	R627	2G	3L	R672	6J	2M	W504	5C	3M
Q601	8J	2N	R628	4H	2K	R673	5D	4M	W505	4C	3M
Q602	3K	2K	R630	6L	2N	R674	5D	4M	W506	3E	3N
Q603	3K	2K	R631	4J	3L	R686	2H	3L	W507	4C	5N
Q604	2K	3K	R636	8H	5N	R687	2J	3L	W510	4E	6M
Q605	2K	3K	R637	8H	3N	R688	2J	3K	W603	1G	4L
Q606	3J	2K	R638	8J	3N	R689	1L	2K	W604	4J	3L
Q607	3J	2K	R639	1H	3L	R690	1L	2K	W605	6L	5L
Q608	6K	2M	R640	2H	3L	R691	1L	2L	W610	3K	3N
			R641	5H	4M	R692	1L	2L	W611	2L	3N
R501	6B	1L	R642	5J	3M	R693	2L	2L	W2502	3M	1L
R502	4E	5N	R643	5H	3M	R694	2L	2L	W2502	8A	1L
R601	7J	3N	R644	5J	3M						
R602	8K	2N	R645	6H	3M	U501	3C	5M	Y600	6K	3M
R603	7K	1N	R646	4K	3M						

Partial A10 also shown on diagrams 1, 2, 3, 5, 6, 7 and 15.

***See Parts List for serial number ranges.**

A B C D E F G H J K L M N

1
2
3
4
5
6
7
8

← WAVEFORMS

PROCESSOR INTERFACE

TRIGGER LOGIC

LEVEL SHIFTERS

DISPLAY LOGIC

HOLDOFF OSCILLATOR

CIRCUIT NUMBER	+5V	GND
U501	16	8
U502	16	8
U503	16	8
U600	40	20
U601	8	4
U602	10, 13, 16, 25, 28, 31	1, 21
U603	1, 16	8
U604	1, 16	8
U606	14	7

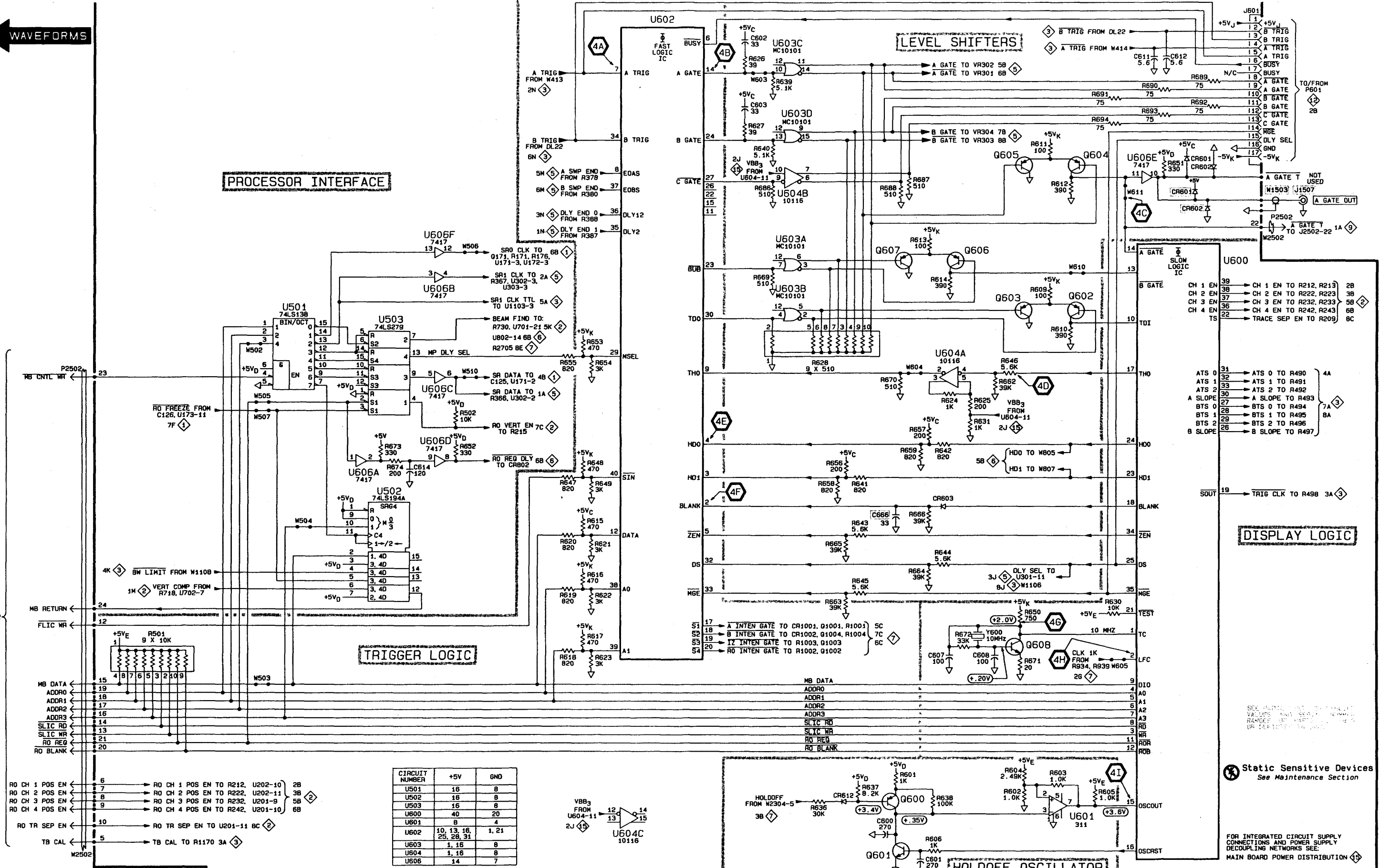

PARTIAL A10 MAIN BOARD

2247A

6367-04
REV MAR 1990

DISPLAY AND TRIGGER LOGIC AND PROCESSOR INTERFACE

⊗ Static Sensitive Devices
See Maintenance Section

FOR INTEGRATED CIRCUIT SUPPLY CONNECTIONS AND POWER SUPPLY DECOUPLING NETWORKS SEE MAIN BOARD POWER DISTRIBUTION

WAVEFORMS FOR DIAGRAM 5

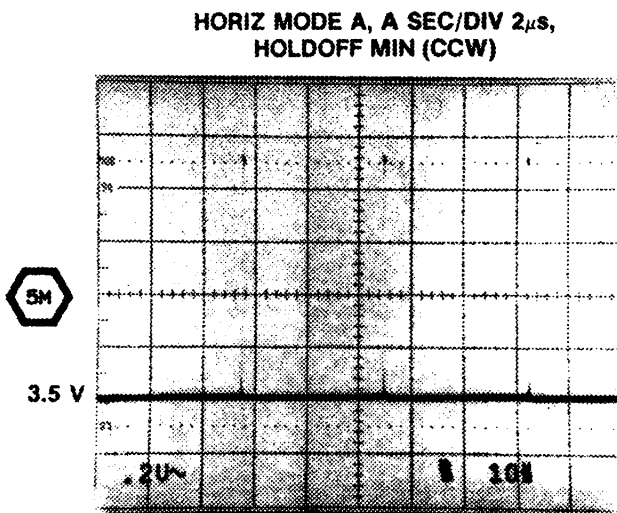
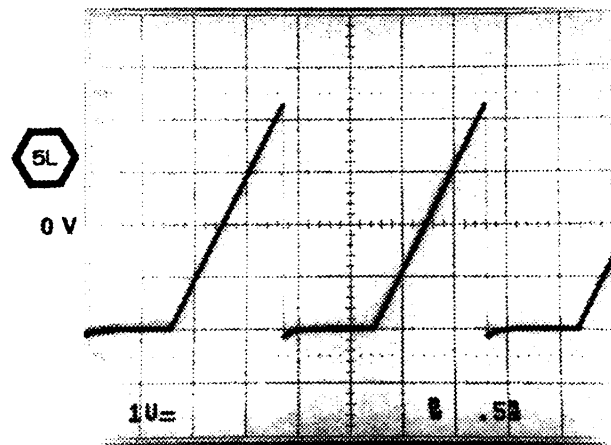
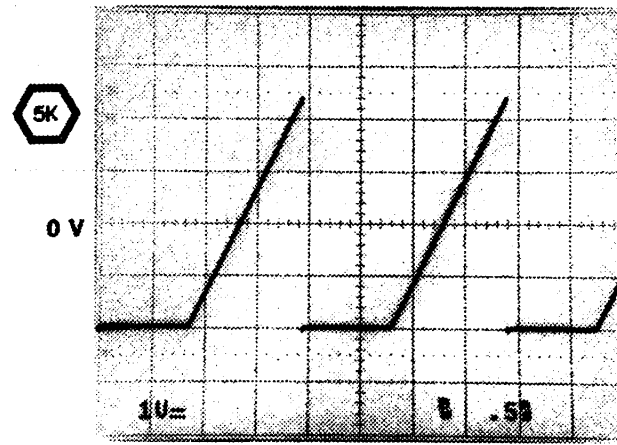
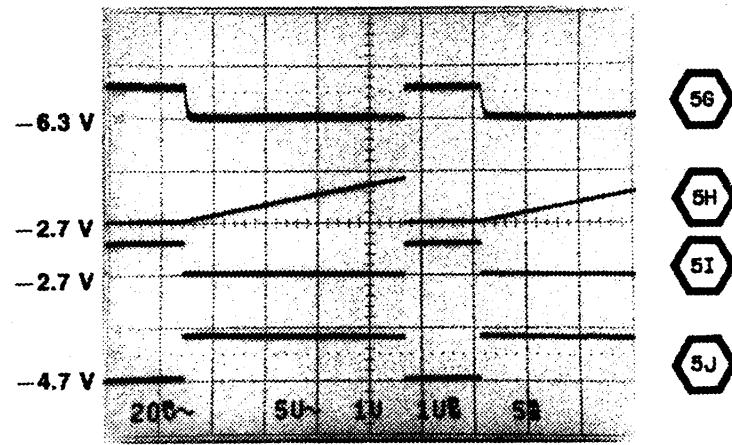
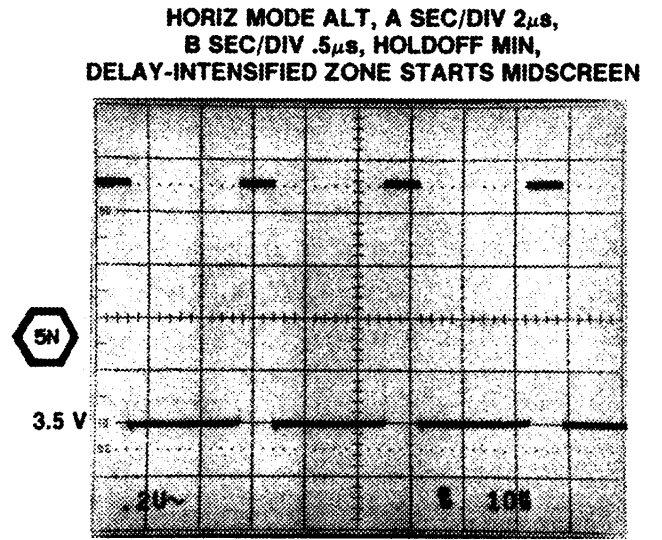
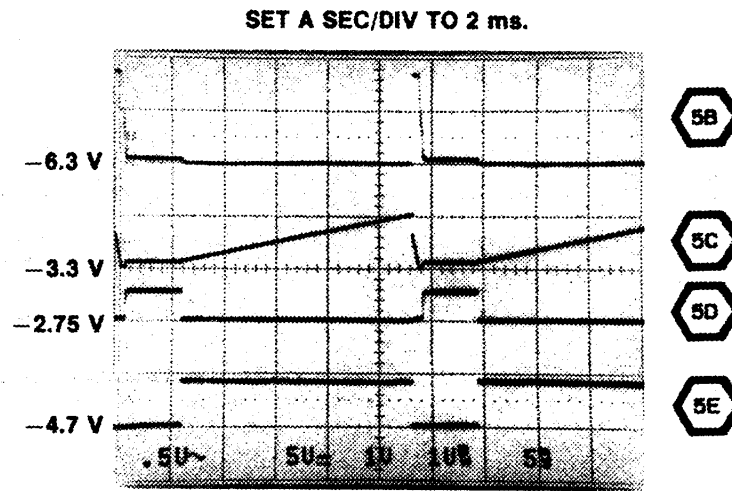
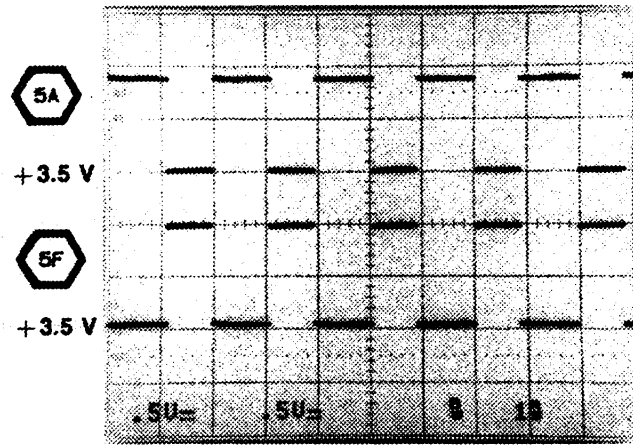

MORE

A AND B SWEEPS AND DELAY COMPARATORS DIAGRAM 5

ASSEMBLY A10											
CIRCUIT NUMBER	SCHEM LOCATION	BOARD LOCATION	CIRCUIT NUMBER	SCHEM LOCATION	BOARD LOCATION	CIRCUIT NUMBER	SCHEM LOCATION	BOARD LOCATION	CIRCUIT NUMBER	SCHEM LOCATION	BOARD LOCATION
C301	4D	8F	Q326	5D	7F	R333	5D	8G	R381	7D	10F
C302	7D	9F	Q328	4K	8E	R334	5B	8G	R382	6L	7G
C303	3D	8C	Q329	6K	9E	R335	3L	9F	R383	8B	9G
C305	4B	9D	Q330	4H	8F	R336	3L	9F	R384	5E	8D
C306	4A	7C	Q331	8H	9F	R337	2M	8F	R385	1M	9G
C307A	5J	7E	Q332	7B	9F	R338	4L	8E	R386	1M	9G
C307B	5J	7E	Q333	5B	8F	R340	6C	7G	R387	1M	8G
C307C	7J	10F				R341	1L	9F	R388	3M	8G
C308	4H	7E	R301	6C	9E	R342	2L	9E	R393	4H	10F
C310	4J	7E	R302	4J	7E	R343	1L	9F	R394	6H	10E
C311	5C	7F	R303	4C	8F	R344	4K	8E	R395	5J	8E
C312	3J	9E	R304	5C	8F	R346	6K	8E	R396	7J	10E
C313	2J	9E	R305	5C	8G	R347	5K	8E			
C314	5J	7F	R306	4B	7C	R348	5L	8H	U301A	1K	9D
C315	5J	7G	R307	4A	7C	R349	5L	7H	U301C	2K	9D
C321	7C	9F	R308	4A	7C	R350A	6M	7H	U302	1B	8C
C326	7H	10E	R309	3C	9C	R350B	7M	7H	U303	2C	9C
C329	7J	10F	R310	3C	7C	R350C	6L	7H	U304A	3H	8D
C330	7J	10G	R311	3D	8C	R350E	5L	7H	U304B	6H	8D
			R313A	4D	7D	R352	6L	7H	U307	2F	7D
CR301	3C	7C	R313B	3D	7D	R354	6B	9E	U308	2G	7D
			R313C	3D	7D	R355	6C	9E	U308A	4A	7C
Q301	3D	7C	R313D	3D	7D	R356	7B	9F	U308B	3D	7C
Q302	4B	8E	R314	3D	7C	R357B	1M	8F	U310	5F	10D
Q303	4C	8F	R315	8K	10E	R357C	1M	8F	U311	5G	10D
Q304	4D	8F	R316	5D	7F	R357D	3M	8F	U313	3M	8E
Q305	4J	7E	R317	4B	8E	R357E	3M	8F	U315A	1M	8F
Q306	4J	7E	R318	4C	8E	R359	2M	8G	U315B	4M	8F
Q307	3H	8D	R319	5B	8F	R360	3M	8G	U315C	2M	8F
Q308	5D	8F	R320	5K	8E	R361	6D	8G	U316A	6M	7H
Q309	5C	8F	R321A	6F	8D	R362	4C	8F	U316B	6L	7H
Q310A	5J	8E	R321B	6F	8D	R363	7C	9F	U316C	6L	7H
Q310B	5J	8E	R321C	6F	8D	R364	8C	9G	U316D	6M	7H
Q311	5C	8F	R321D	3F	8D	R365	7H	10E			
Q312	5K	8E	R321E	3F	8D	R366	1A	8C	VR301	6B	8G
Q313	8D	9F	R321F	3F	8D	R367	2A	8C	VR302	5B	8G
Q315	6B	9E	R322	5L	7H	R370	8C	9G	VR303	8B	8G
Q316	7C	9F	R323	7L	7G	R371	8D	9G	VR304	7B	8G
Q317	7D	9F	R325	4H	7D	R372	8D	9G	VR308	7C	9F
Q318	7J	10E	R326	4J	7D	R373	8C	10G	VR309	5C	7G
Q320	6H	9E	R327	7C	9F	R375	8K	10E	VR310	8C	9G
Q321	7D	9F	R328	3M	8E	R376	7K	10E	VR311	6K	8E
Q322	7C	9F	R329	3J	9E	R377	6L	8G	VR312	8K	10E
Q323A	7J	9E	R330	2J	9E	R378	5M	6J			
Q323B	8J	9E	R331	3K	8E	R379	6L	7H	W304	7K	8G
Q325	7K	10E	R332	5C	7G	R380	6M	6J	W802	5K	8G

Partial A10 also shown on diagrams 1, 2, 3, 4, 6, 7 and 15.

A B C D E F G H J K L M N

1
2
3
4
5
6
7
8

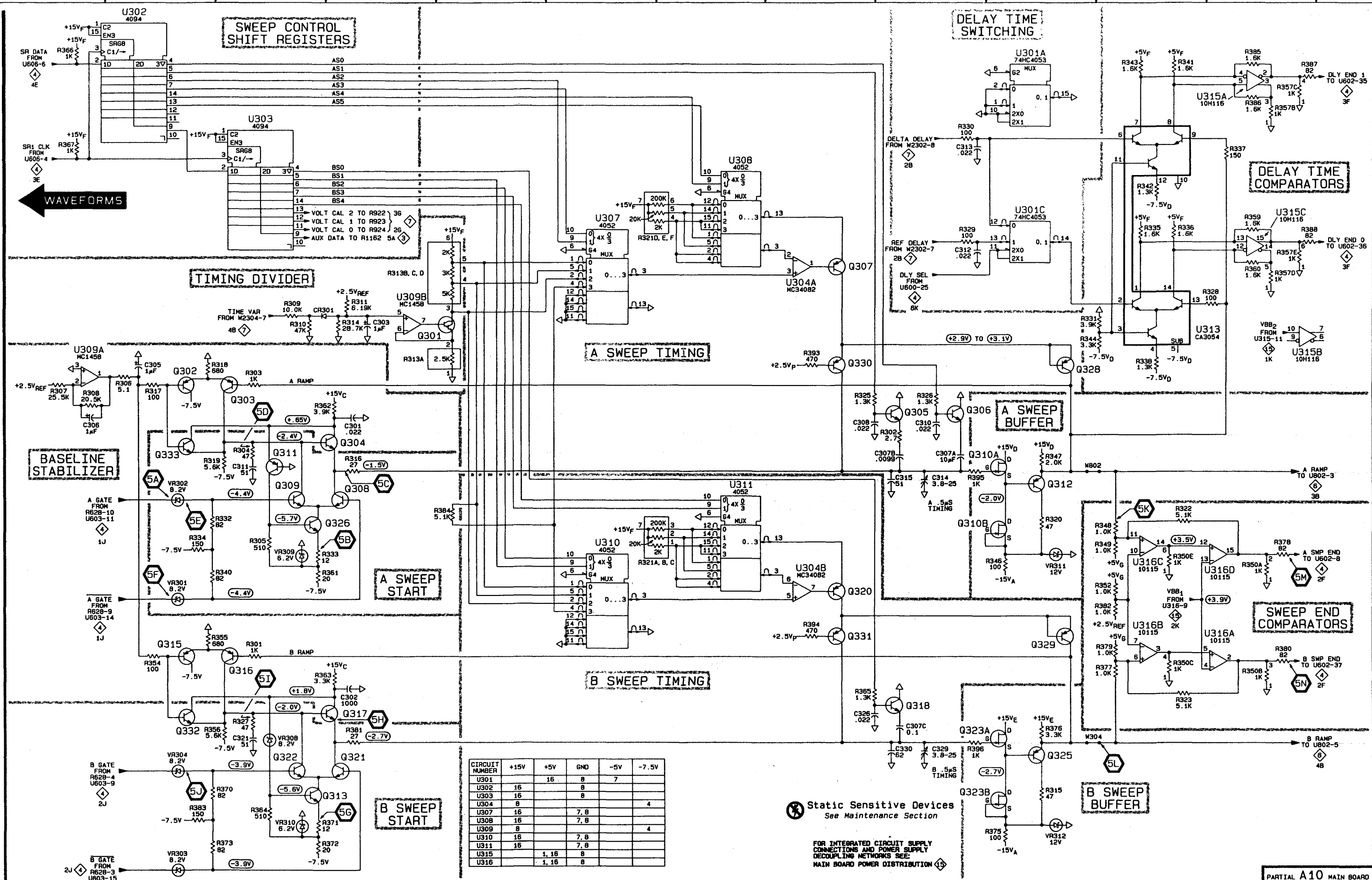

CIRCUIT NUMBER	+15V	+5V	GND	-5V	-7.5V
U301		16	8	7	
U302	16		8		
U303	16		8		
U304	8		7, 8		4
U307	16		7, 8		
U308	16		7, 8		
U309	8			7, 8	4
U310	16		7, 8		
U311	16		7, 8		
U315		1, 16	8		
U316		1, 16	8		

⊗ Static Sensitive Devices
See Maintenance Section

FOR INTEGRATED CIRCUIT SUPPLY
CONNECTIONS AND POWER SUPPLY
DECOUPLING NETWORKS SEE:
MAIN BOARD POWER DISTRIBUTION

WAVEFORMS FOR DIAGRAM 6

A AND B SWEEPS AND DELAY COMPARATORS DIAGRAM 5

ASSEMBLY A10											
CIRCUIT NUMBER	SCHEM LOCATION	BOARD LOCATION	CIRCUIT NUMBER	SCHEM LOCATION	BOARD LOCATION	CIRCUIT NUMBER	SCHEM LOCATION	BOARD LOCATION	CIRCUIT NUMBER	SCHEM LOCATION	BOARD LOCATION
C301	4D	8F	Q326	5D	7F	R333	5D	8G	R381	7D	10F
C302	7D	9F	Q328	4K	8E	R334	5B	8G	R382	6L	7G
C303	3D	8C	Q329	6K	9E	R335	3L	9F	R383	8B	9G
C305	4B	9D	Q330	4H	8F	R336	3L	9F	R384	5E	8D
C306	4A	7C	Q331	8H	9F	R337	2M	8F	R385	1M	9G
C307A	5J	7E	Q332	7B	9F	R338	4L	8E	R386	1M	9G
C307B	5J	7E	Q333	5B	8F	R340	6C	7G	R387	1M	8G
C307C	7J	10F				R341	1L	9F	R388	3M	8G
C308	4H	7E	R301	6C	9E	R342	2L	9E	R393	4H	10F
C310	4J	7E	R302	4J	7E	R343	1L	9F	R394	8H	10E
C311	5C	7F	R303	4C	8E	R344	4K	8E	R395	5J	8E
C312	3J	9E	R304	5C	8F	R346	8K	8E	R396	7J	10E
C313	2J	9E	R305	5C	8G	R347	5K	8E			
C314	5J	7F	R306	4B	7C	R348	5L	8H	U301A	1K	9D
C315	5J	7G	R307	4A	7C	R349	5L	7H	U301C	2K	9D
C321	7C	9F	R308	4A	7C	R350A	6M	7H	U302	1B	8C
C326	7H	10E	R309	3C	9C	R350B	7M	7H	U303	2C	9C
C329	7J	10F	R310	3C	7C	R350C	6L	7H	U304A	3H	8D
C330	7J	10G	R311	3D	8C	R350E	5L	7H	U304B	8H	8D
			R313A	4D	7D	R352	6L	7H	U307	2F	7D
CR301	3C	7C	R313B	3D	7D	R354	6B	9E	U308	2G	7D
			R313C	3D	7D	R355	6C	9E	U309A	4A	7C
Q301	3D	7C	R313D	3D	7D	R356	7B	9F	U309B	3D	7C
Q302	4B	8E	R314	3D	7C	R357B	1M	8F	U310	5F	10D
Q303	4C	8F	R315	8K	10E	R357C	1M	8F	U311	5G	10D
Q304	4D	8F	R316	5D	7F	R357D	3M	8F	U313	3M	8E
Q305	4J	7E	R317	4B	8E	R357E	2M	8F	U315A	1M	8F
Q306	4J	7E	R318	4C	8E	R359	3M	8G	U315B	4M	8F
Q307	3H	8D	R319	5B	8F	R360	3M	8G	U315C	2M	8F
Q308	5D	8F	R320	5K	8E	R361	6D	8G	U316A	6M	7H
Q309	5C	8F	R321A	6F	8D	R362	4C	8F	U316B	6L	7H
Q310A	5J	8E	R321B	6F	8D	R363	7C	9F	U316C	6L	7H
Q310B	5J	8E	R321C	6F	8D	R364	8C	9G	U318D	6M	7H
Q311	5C	8F	R321D	3F	8D	R365	7H	10E			
Q312	5K	8E	R321E	3F	8D	R366	1A	8C	VR301	6B	8G
Q313	8D	9F	R321F	3F	8D	R367	2A	8C	VR302	5B	8G
Q315	6B	9E	R322	5L	7H	R370	8C	9G	VR303	8B	8G
Q316	7C	9F	R323	7L	7G	R371	8D	9G	VR304	7B	8G
Q317	7D	9F	R325	4H	7D	R372	8D	9G	VR308	7C	9F
Q318	7J	10E	R326	4J	7D	R373	8C	10G	VR309	5C	7G
Q320	8H	9E	R327	7C	9F	R375	8K	10E	VR310	8C	9G
Q321	7D	9F	R328	3M	8E	R376	7K	10E	VR311	6K	8E
Q322	7C	9F	R329	3J	9E	R377	6L	8G	VR312	8K	10E
Q323A	7J	9E	R330	2J	9E	R378	5M	6J			
Q323B	8J	9E	R331	3K	8E	R379	6L	7H	W304	7K	8G
Q325	7K	10E	R332	5C	7G	R380	6M	6J	W802	5K	8G

Partial A10 also shown on diagrams 1, 2, 3, 4, 6, 7 and 15.

WAVEFORMS FOR DIAGRAM 6

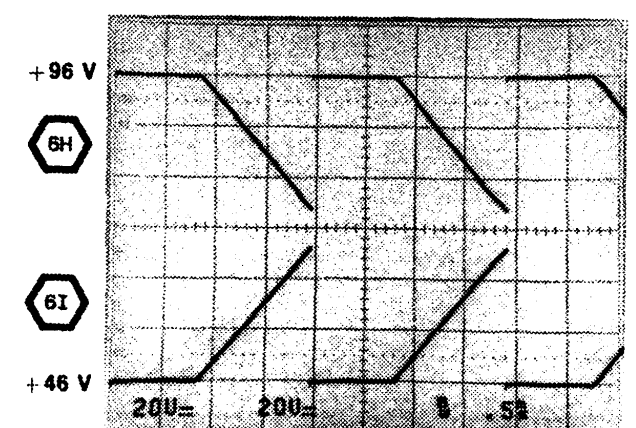
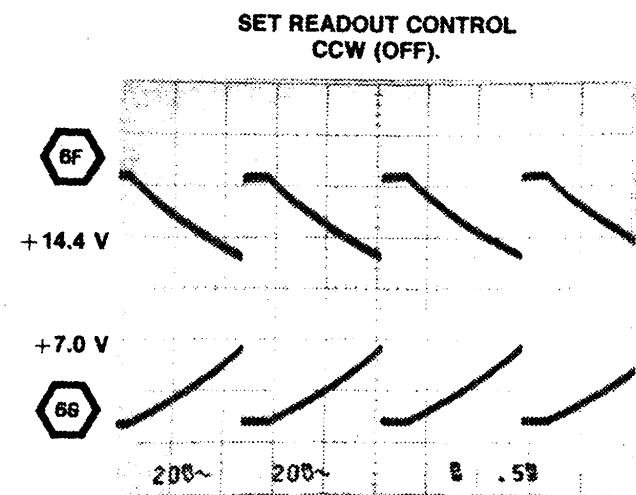
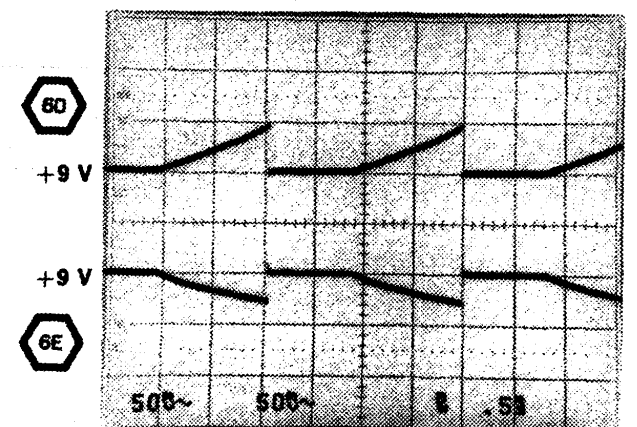
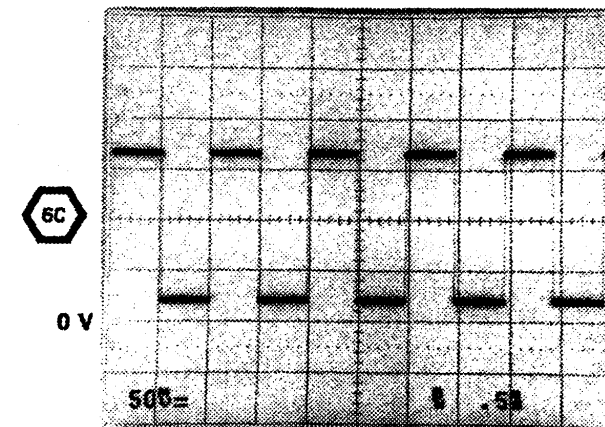
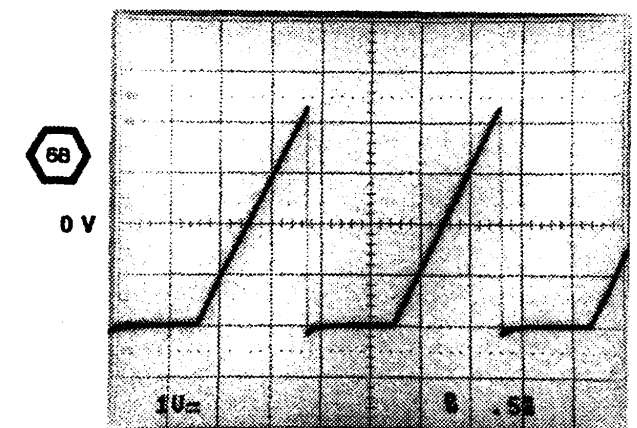
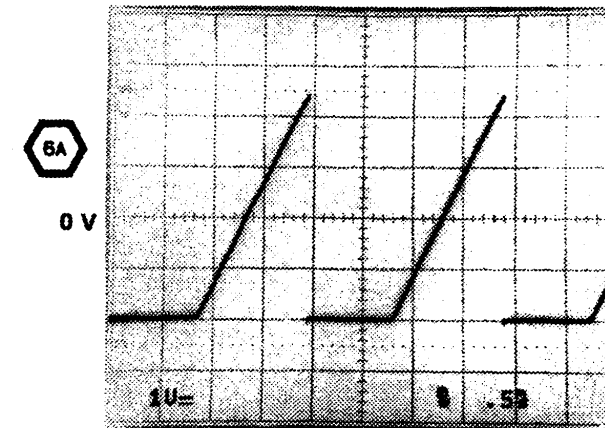

A B C D E F G H J K L M N

← WAVEFORMS

HORIZONTAL PREAMPLIFIER

DRIVER AMPLIFIERS

HORIZONTAL OUTPUT AMPLIFIERS

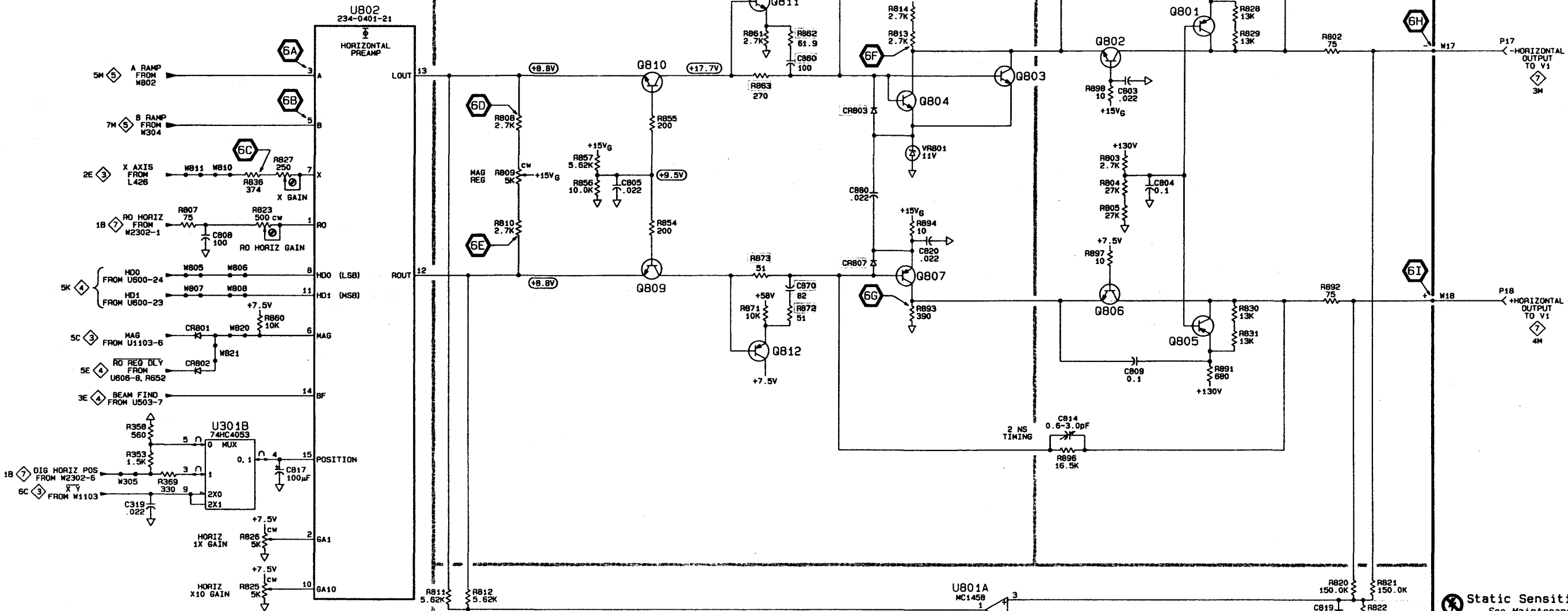

COMMON MODE STABILIZER

CIRCUIT NUMBER	+15V	+7.5V	+5V	GND	-5V
U301			16	8	7
U801	8			4	4
U802		16		4	9

⊗ Static Sensitive Devices
See Maintenance Section

FOR INTEGRATED CIRCUIT SUPPLY CONNECTIONS AND POWER SUPPLY DECOUPLING NETWORKS SEE: MAIN BOARD POWER DISTRIBUTION

PARTIAL A10 MAIN BOARD

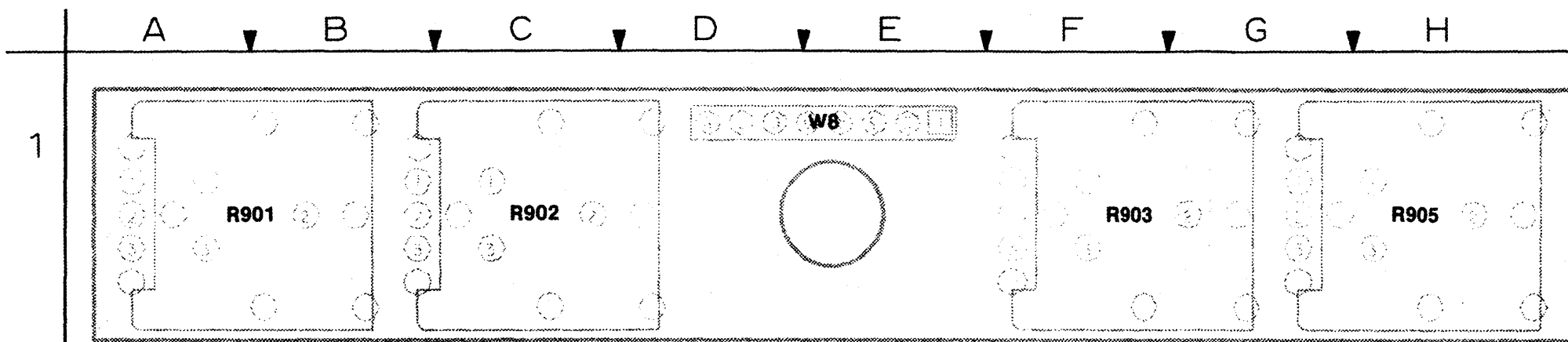

6081-32

Figure 9-7. A8—CRT Control board.

Static Sensitive Devices
See Maintenance Section

COMPONENT NUMBER EXAMPLE

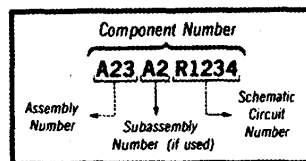

Chassis-mounted components have no Assembly Number prefix—see end of Replaceable Electrical Parts List.

A8—CRT CONTROL BOARD			
CIRCUIT NUMBER	SCHEM NUMBER	CIRCUIT NUMBER	SCHEM NUMBER
R901	7		
R902	7	W900	7
R903	7	W900	15
R905	7		

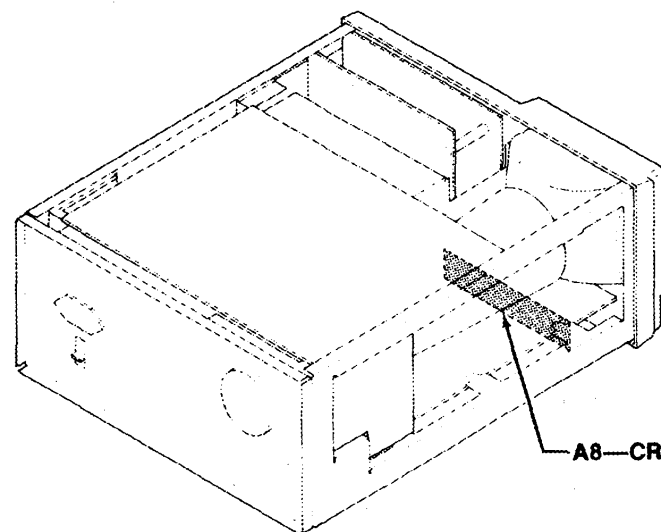

A8—CRT CONTROL BOARD

WAVEFORMS FOR DIAGRAM 7

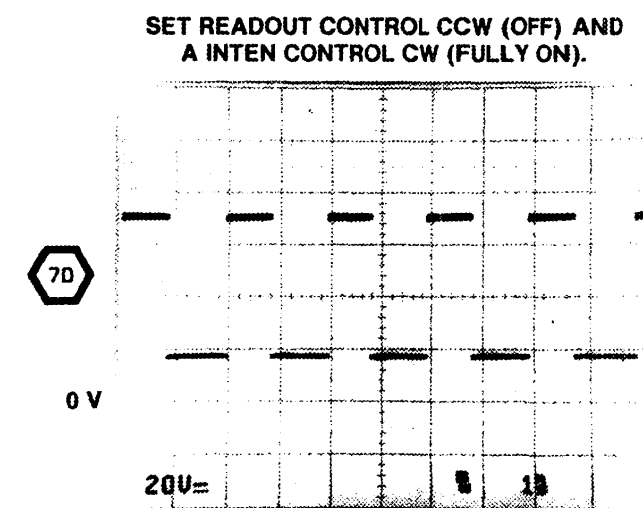
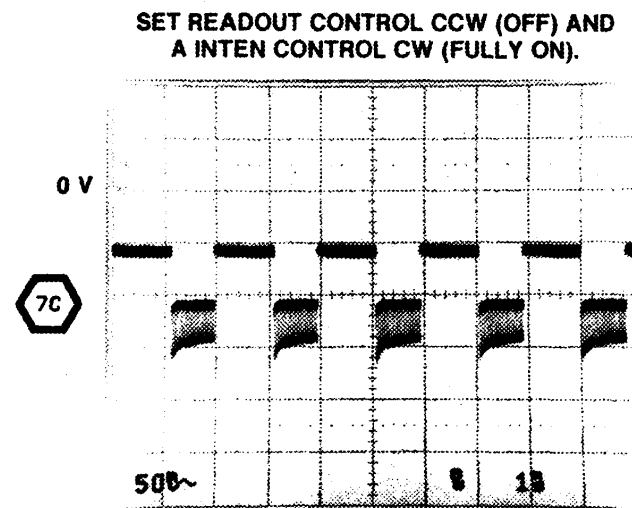
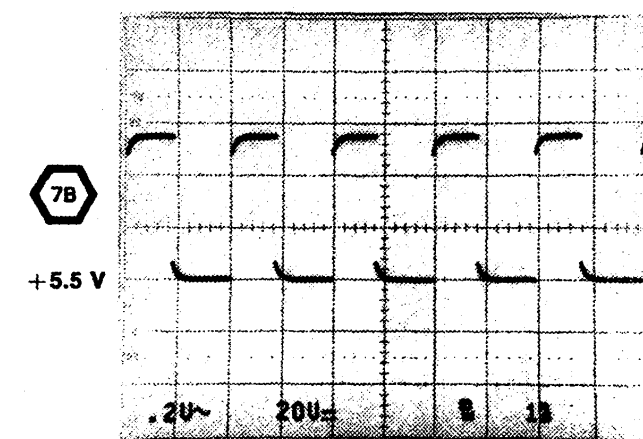
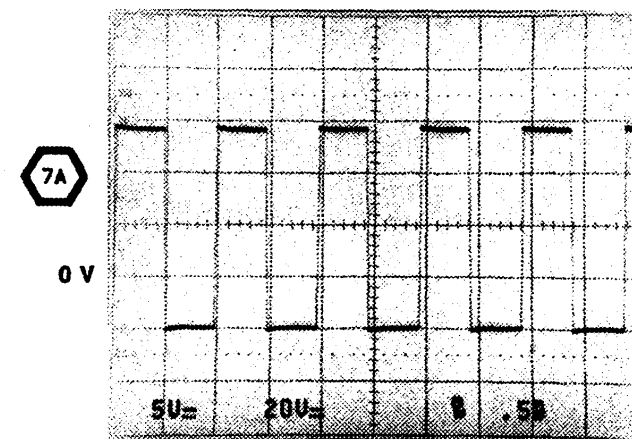

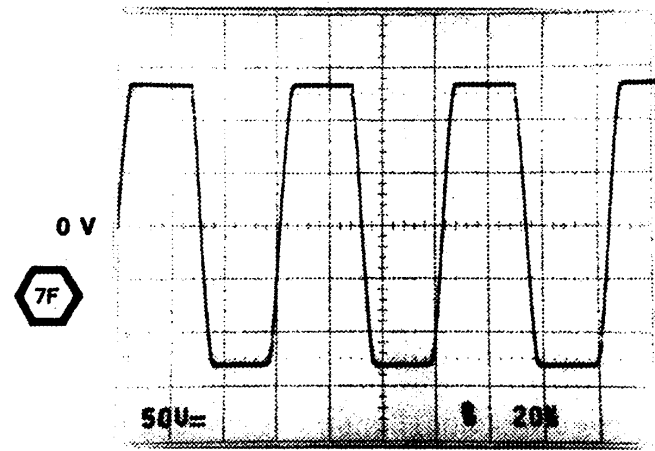
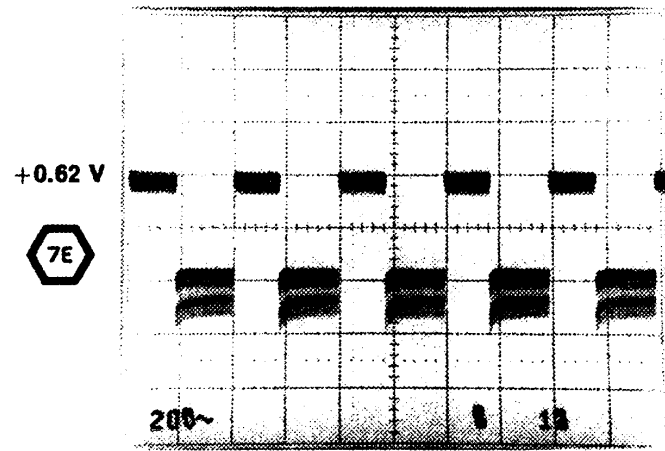

SET READOUT CONTROL CCW (OFF) AND
A INTEN CONTROL CW (FULLY ON).

SET READOUT CONTROL CCW (OFF),
A INTEN CCW (OFF), B INTEN CW (FULLY
ON), AND HORIZONTAL MODE TO ALT.

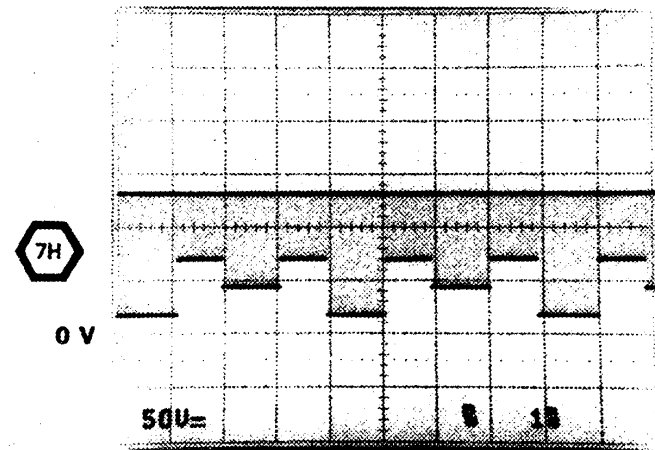
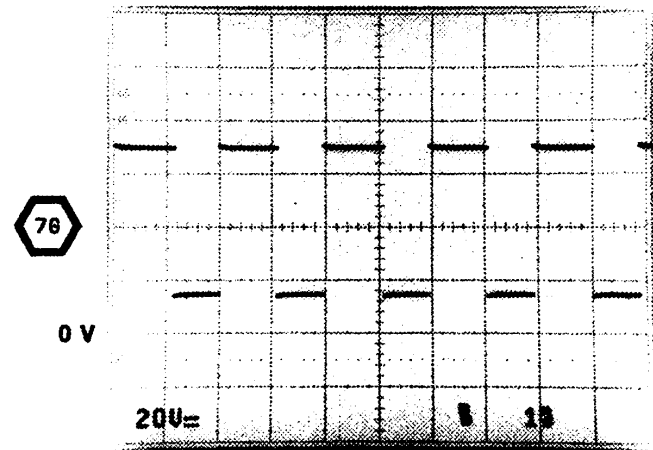

SET READOUT CONTROL CCW (OFF),
A INTEN CCW (OFF), B INTEN CW (FULLY
ON), AND HORIZONTAL MODE TO ALT.

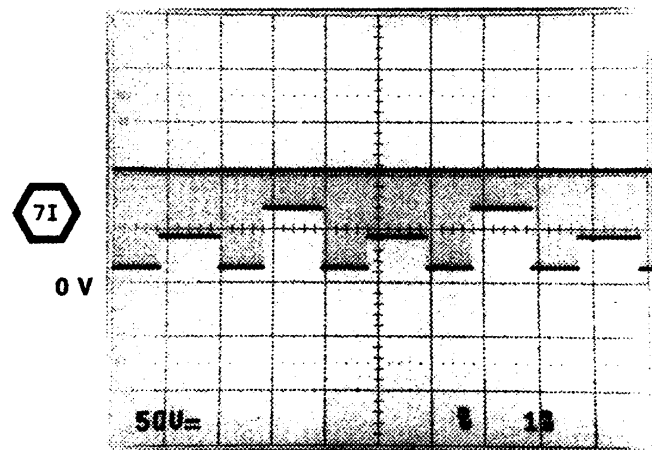

Z-AXIS, CRT, PROBE ADJUST AND CONTROL MUX DIAGRAM 7

ASSEMBLY A8											
CIRCUIT NUMBER	SCHEM LOCATION	BOARD LOCATION	CIRCUIT NUMBER	SCHEM LOCATION	BOARD LOCATION	CIRCUIT NUMBER	SCHEM LOCATION	BOARD LOCATION	CIRCUIT NUMBER	SCHEM LOCATION	BOARD LOCATION
R901	5A	1A	R903	6A	1F	W900	4A	1E			
R902	6A	1C	R905	4A	1H						
<i>Partial A8 also shown on diagram 15.</i>											
ASSEMBLY A10											
C910	2L	10B	DS2701	8L	9N	R930	1H	8B	R2726	5E	6L
C935	2H	7B	DS2702	7L	9M	R931	1H	7A	R2727	5E	7L
C1001	5C	7L	DS2703	5K	9M	R932	1H	7B	R2728	5E	6L
C1002	6C	8M	DS2704	6K	9M	R933	1H	7B	R2729	6E	7L
C1003	6C	8M				R934	2G	7B	R2733	6F	9L
C1004	7C	7L	J15	2K	7A	R935	2H	7B	R2734	6F	10L
C2703	7G	7M	J927	2L	10B	R936	1J	7A	R2735	5G	10L
C2704	6G	7M				R937	2J	7A	R2736	5G	10L
C2705	7G	7N	P8	8A	10N	R938	1G	7B	R2737	5G	10K
C2706	7H	6N	P9	3M	8N	R939	2G	7B	R2738	5G	10L
C2707	7H	7M	P9	4M	10N	R940	2J	7A	R2739	4H	10L
C2708	6H	7N	P2302	1A	10D	R941*	1H	8A	R2740	5J	10L
C2710	7J	7N	P2304	3A	10D	R1001	5C	4L	R2741	5J	8M
C2711	7K	8M				R1002	6C	5M	R2742	6J	8L
C2712	7K	8N	Q905	4E	10A	R1003	6C	4L	R2743	6H	8L
C2713	7K	6N	Q907	4E	10A	R1004	7C	4L	R2745	7J	7N
C2715	6G	10L	Q908	4F	10A	R1005	5C	8L	R2750	6J	8M
C2716	5H	10L	Q1001	5D	4L	R1006	6D	7L	R2751	6K	9M
C2717	5H	10L	Q1002	6D	4L	R1007	7D	8L	R2758	6L	9L
C2719	5J	10M	Q1003	6D	4L	R1008	7D	8L	R2760	6L	10M
C2720	6J	8L	Q1004	7D	4L	R1009	8C	7L	R2765	7F	7M
C2721	6J	6K	Q1005	8D	7L	R1010	8B	7K	R2784	3L	7N
C2723	6E	7L	Q2701	7H	7N	R1020	5B	7L	R2785	3L	8N
C2724	7K	10M	Q2702	7H	7M	R1021	5B	7L	R2786	4L	6N
C2759	7F	7M	Q2703	7H	7N	R1022	6B	7L	R2787	5L	6N
C2783	3L	8N	Q2704	8H	6N	R1023	6B	7L	R2788	5L	7N
C2784	5L	6N	Q2705	7G	6M	R1024	7B	7L	R2789	5L	8N
C2785	5L	8N	Q2706	8F	7M	R1025	7B	8L	R2795	7E	7L
			Q2707	7F	6M	R1028	5D	4L	R2796	6F	6M
			Q2708	5E	8L	R2701	7E	6L			
CR935	2J	7A	Q2709	5F	6L	R2702	7E	6L	U506	2E	10C
CR936	2J	7A	Q2711	5G	10L	R2703	6E	7L	U930A	1H	8B
CR1001	5D	4L	Q2712	5H	10L	R2704	6E	7L	U930B	2H	8B
CR1002	7D	4L	Q2713	5H	10L	R2705	7F	7L	U931	3H	9B
CR1003	8C	8L	Q2715	7F	6M	R2706	7F	7M	U1001A	7B	7L
CR1004	7C	7L				R2708	6G	7M	U1001B	6B	7L
CR1005	5D	3L				R2709	6G	7M	U1001C	6B	7L
CR2701	7K	9M	R503	2B	10C	R2710	8G	6M	U1001D	5B	7L
CR2702	7K	9M	R508	2B	10C	R2711	7G	7N			
CR2703	7K	8N	R510	2B	10C	R2712	7G	7M	VR2701	7G	6M
CR2704	7K	6N	R512	3B	10C	R2713	7G	7M			
CR2705	8G	6M	R906	4E	10B	R2714	7G	7M	W9	3M	8N
CR2707	7F	7L	R907	4E	10A	R2715	7G	7M	W9	8A	10N
CR2713	6H	10L	R908	4F	10A	R2716	6G	7M	W9	8M	10N
CR2714	5H	10L	R909	5D	8B	R2717	6H	7M	W16	8A	7L
CR2715	5J	9L	R910	2L	10B	R2718	7J	7M	W906*	1H	8A
CR2716	5K	9M	R911	2L	8A	R2719	7J	7N	W1000	5D	3L
CR2717	6K	9M	R920	3G	8B	R2720	7J	8N	W1288	8J	6J
CR2718	5J	8L	R921	3G	8B	R2721	7K	9N	W2302	3A	10D
			R922	3H	9C	R2722	8K	6L	W2304	4A	10D
DS901	4E	8A	R923	3H	9C	R2723	7K	9M	W2701	7D	6M
DS902	4F	9A	R924	2H	9C	R2724	7K	7N			
DS903	4F	10A									
<i>Partial A10 also shown on diagrams 1, 2, 3, 4, 5, 6 and 15.</i>											
OTHER PARTS											
J16	7A	CHASSIS	P26 P27	1L 2M	CHASSIS CHASSIS	V1	1M	CHASSIS			

*See Parts List for serial number ranges.

A B C D E F G H J K L M N

WAVEFORMS

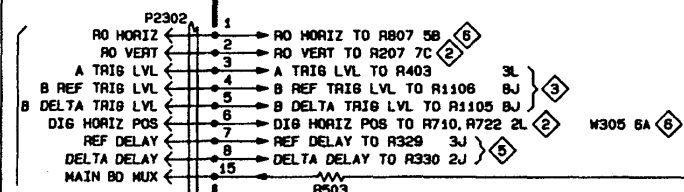

CONTROL MULTIPLEXER

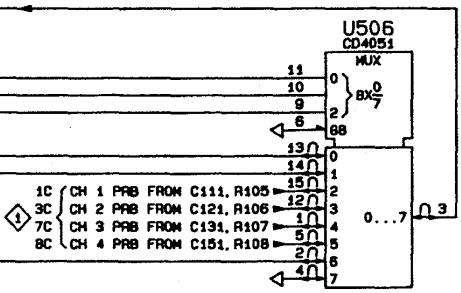

SCALE ILLUMINATION

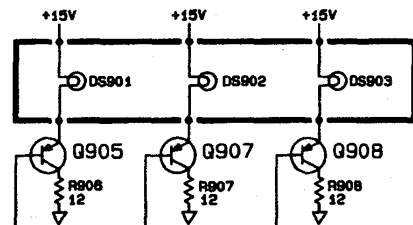

PROBE ADJUST

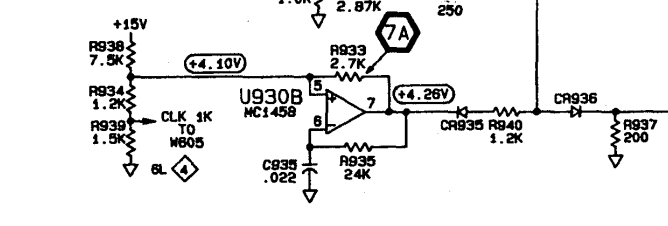

CIRCUIT NUMBER	+15V	+7.5V	+5V	GND	-5V	-7.5V
U506			16	8		7
U930	8				16	7
U931					16	7
U1001		4				11

Static Sensitive Devices
See Maintenance Section

FOR INTEGRATED CIRCUIT SUPPLY CONNECTIONS AND POWER SUPPLY DECOUPLING NETWORKS SEE: MAIN BOARD POWER DISTRIBUTION

VOLTS CAL SIGNAL SOURCE

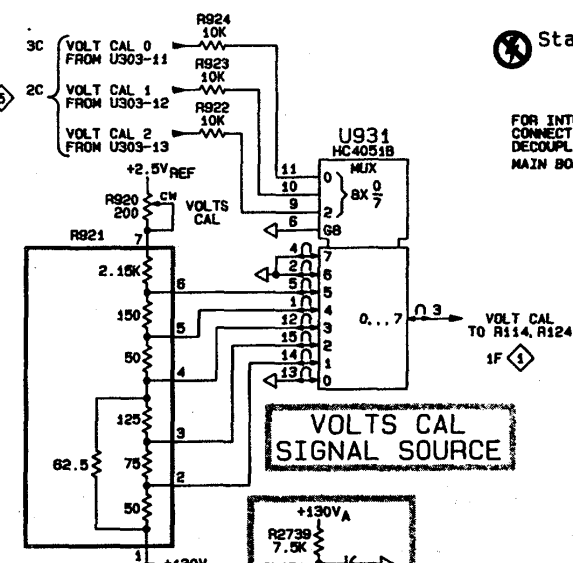

Z-AXIS & AUTO FOCUS AMPLIFIERS

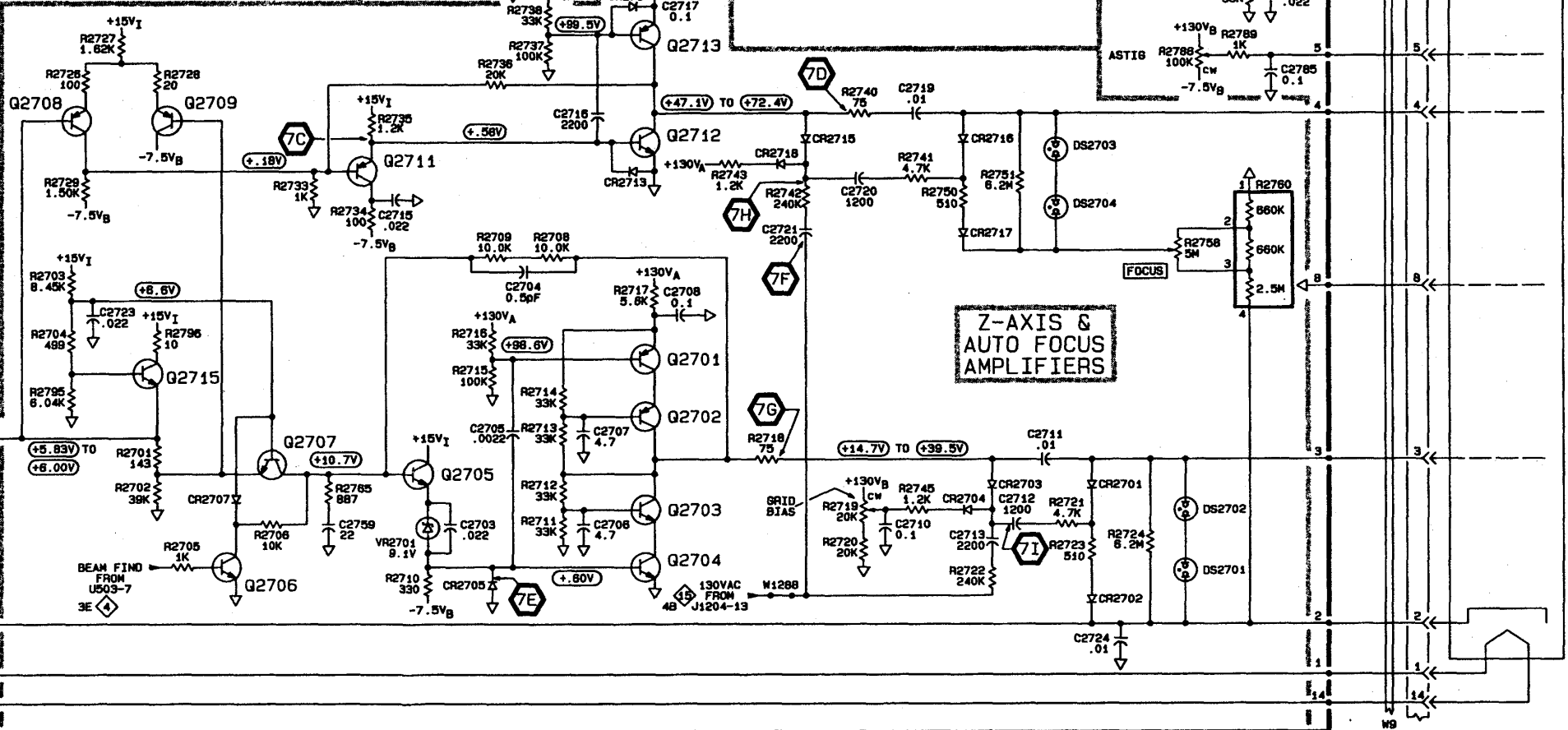

CRT

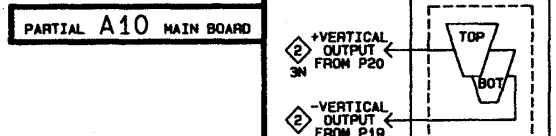

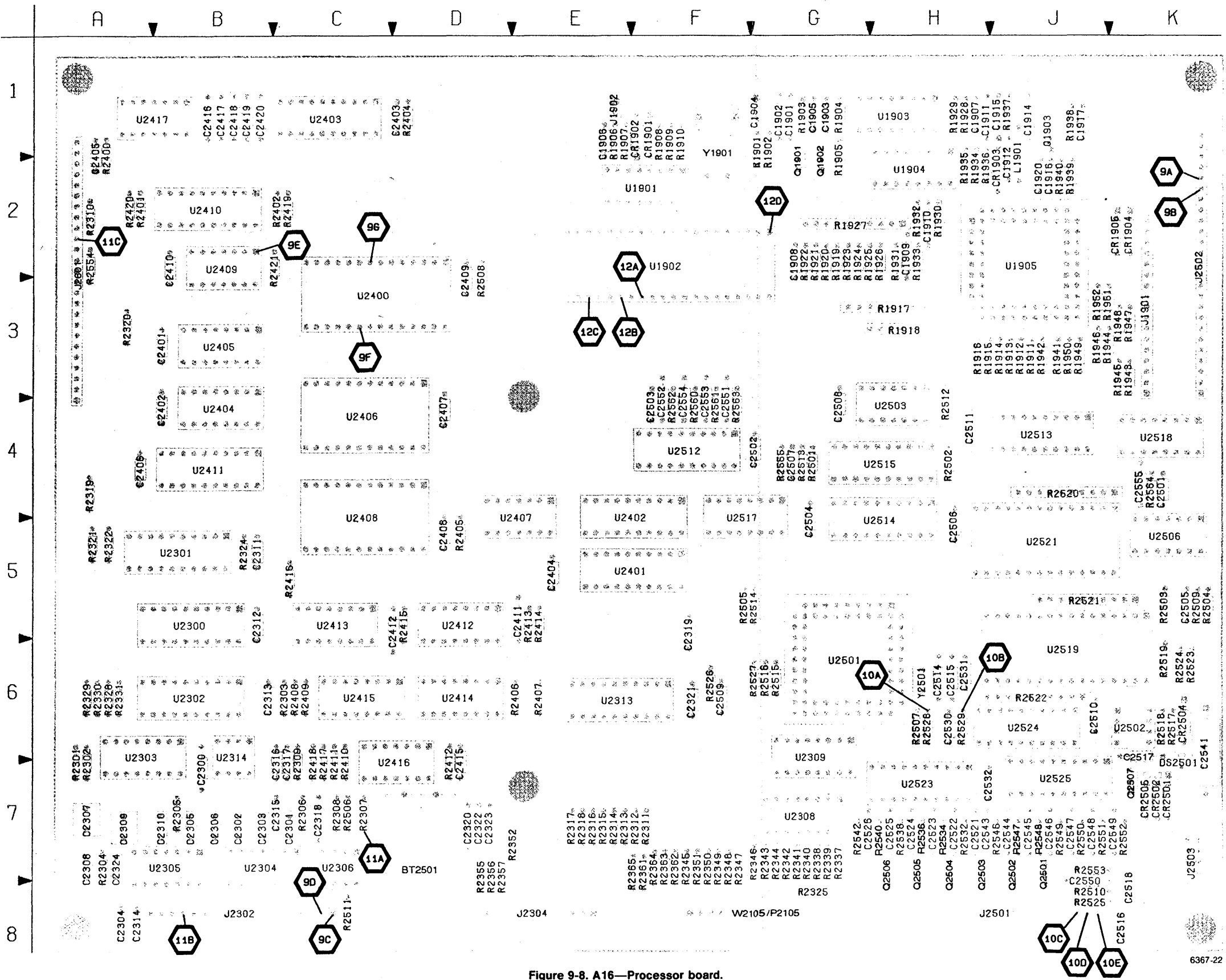

Static Sensitive Devices
See Maintenance Section

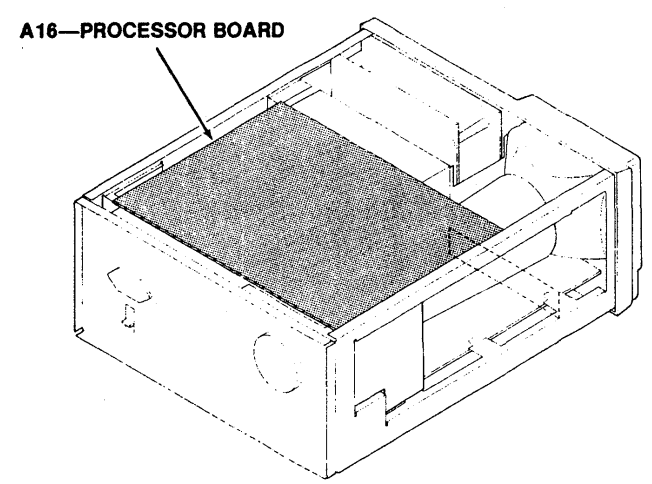
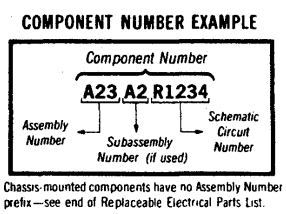
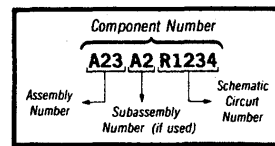

Figure 9-8. A16—Processor board.

 **Static Sensitive Devices**
See Maintenance Section

COMPONENT NUMBER EXAMPLE



Chassis-mounted components have no Assembly Number prefix—see end of Replaceable Electrical Parts List.

A16—PROCESSOR BOARD

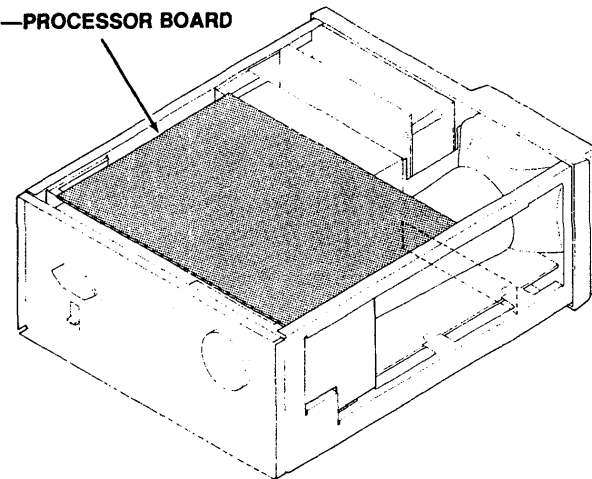

A16—PROCESSOR BOARD

CIRCUIT NUMBER	SCHEM NUMBER	CIRCUIT NUMBER	SCHEM NUMBER	CIRCUIT NUMBER	SCHEM NUMBER	CIRCUIT NUMBER	SCHEM NUMBER	CIRCUIT NUMBER	SCHEM NUMBER	CIRCUIT NUMBER	SCHEM NUMBER
BT2501	8	C2509	16	Q2504	10	R2314	11	R2511	8	U2401	9
		C2510	16	Q2505	10	R2315	11	R2512	8	U2401	16
C1901	12	C2511	16	Q2506	10	R2316	11	R2513	8	U2402	9
C1902	12	C2514	8	Q2507	8	R2317	11	R2514	8	U2402	16
C1903	12	C2515	8			R2318	11	R2515	8	U2403	9
C1904	12	C2516	8	R1901	12	R2319	11	R2516	8	U2403	16
C1905	12	C2517	8	R1902	12	R2320	11	R2517	8	U2404	9
C1906	12	C2518	8	R1903	12	R2321	11	R2518	8	U2404	16
C1907	12	C2521	10	R1904	12	R2322	11	R2519	8	U2405	9
C1908	16	C2522	10	R1905	12	R2324	11	R2520	8	U2405	16
C1909	12	C2523	10	R1906	12	R2325	11	R2521	8	U2406	9
C1910	12	C2524	10	R1907	12	R2328	11	R2522	8	U2406	16
C1911	12	C2525	10	R1908	12	R2329	11	R2523	8	U2407	9
C1912	12	C2526	10	R1909	12	R2330	11	R2524	8	U2407	16
C1914	12	C2530	16	R1910	12	R2331	11	R2525	10	U2408	9
C1915	16	C2531	16	R1911	12	R2337	11	R2526	8	U2408	16
C1916	12	C2532	16	R1912	12	R2338	11	R2527	8	U2409	9
C1917	12	C2541	16	R1913	12	R2339	11	R2528	10	U2409	16
C1920	12	C2543	10	R1914	12	R2340	11	R2529	10	U2410	9
C2300	11	C2544	10	R1915	12	R2341	11	R2532	10	U2410	16
C2301	11	C2545	10	R1916	12	R2342	11	R2534	10	U2411	9
C2302	11	C2546	10	R1917	12	R2343	11	R2536	10	U2411	16
C2303	11	C2547	10	R1918	12	R2344	11	R2538	10	U2412	9
C2304	16	C2548	10	R1919	12	R2345	11	R2540	10	U2412	16
C2305	11	C2549	10	R1920	12	R2346	11	R2542	10	U2413	9
C2306	11	C2550	10	R1921	12	R2347	11	R2546	10	U2413	16
C2307	11	C2551	8	R1922	12	R2348	11	R2547	10	U2414	9
C2308	11	C2552	8	R1923	12	R2349	11	R2548	10	U2414	16
C2309	11	C2553	8	R1924	12	R2350	11	R2549	10	U2415	9
C2310	11	C2554	8	R1925	12	R2351	11	R2550	10	U2415	16
C2311	16	C2555	8	R1926	12	R2352	11	R2551	10	U2416	9
C2312	16			R1927	12	R2355	11	R2552	10	U2416	16
C2313	16	CR1901	12	R1928	12	R2356	11	R2553	10	U2417	9
C2314	16	CR1902	12	R1929	12	R2357	11	R2554	8	U2417	16
C2315	16	CR1903	12	R1930	12	R2361	11	R2555	8	U2501	8
C2316	16	CR1904	12	R1931	12	R2362	11	R2560	8	U2501	16
C2317	16	CR1905	12	R1932	12	R2363	11	R2561	8	U2502	8
C2318	11	CR2501	8	R1933	12	R2364	11	R2562	8	U2502	16
C2319	16	CR2502	8	R1934	12	R2365	11	R2563	8	U2503	8
C2320	11	CR2504	8	R1935	12	R2400	9	R2564	8	U2503	16
C2321	16	CR2505	8	R1936	12	R2401	9			U2506	8
C2322	11			R1937	12	R2402	9	U1901	12	U2506	16
C2323	11	DS2501	8	R1938	12	R2404	9	U1902	12	U2512	8
C2324	11			R1939	12	R2405	9	U1903	12	U2512	16
C2401	16	J1901	12	R1940	12	R2406	9	U1904	12	U2513	8
C2402	16	J1902	12	R1941	12	R2407	9	U1905	12	U2513	16
C2403	16	J2302	9	R1942	12	R2408	9	U2300	11	U2514	8
C2404	16	J2302	11	R1943	12	R2409	9	U2300	16	U2514	16
C2405	16	J2302	16	R1944	12	R2410	9	U2301	11	U2515	8
C2406	16	J2304	11	R1945	12	R2411	9	U2301	16	U2515	16
C2407	16	J2501	10	R1946	12	R2412	16	U2302	11	U2517	8
C2408	16	J2501	16	R1947	12	R2413	9	U2302	16	U2517	16
C2409	16	J2502	8	R1948	12	R2414	9	U2303	11	U2518	8
C2410	16	J2502	9	R1949	12	R2415	9	U2303	16	U2518	16
C2411	9	J2502	16	R1950	12	R2416	9	U2304	11	U2519	8
C2412	9	J2503	10	R1951	12	R2417	9	U2304	16	U2519	16
C2415	16	J2601	11	R1952	12	R2418	9	U2305	11	U2521	8
C2416	9	J2601	16	R2301	11	R2419	9	U2305	16	U2523	10
C2417	9			R2302	11	R2420	9	U2306	11	U2523	16
C2418	9	L1901	12	R2303	11	R2421	9	U2306	16	U2524	10
C2419	9			R2304	11	R2501	8	U2308	11	U2524	16
C2420	9	P2105	11	R2305	11	R2502	8	U2308	16	U2525	10
C2501	16	P2105	16	R2306	11	R2503	8	U2309	11	U2525	16
C2502	16			R2307	11	R2504	8	U2309	16		
C2503	16	Q1901	12	R2308	11	R2505	8	U2313	11	W2105	11
C2504	16	Q1902	12	R2309	16	R2506	8	U2313	16	W2105	16
C2505	16	Q1903	12	R2310	11	R2507	8	U2314	11		
C2506	16	Q2501	10	R2311	11	R2508	8	U2314	16	Y1901	12
C2507	16	Q2502	10	R2312	11	R2509	8	U2400	9	Y2501	8
C2508	16	Q2503	10	R2313	11	R2510	8	U2400	16		

MEASUREMENT PROCESSOR DIAGRAM 8

ASSEMBLY A16											
CIRCUIT NUMBER	SCHEM LOCATION	BOARD LOCATION	CIRCUIT NUMBER	SCHEM LOCATION	BOARD LOCATION	CIRCUIT NUMBER	SCHEM LOCATION	BOARD LOCATION	CIRCUIT NUMBER	SCHEM LOCATION	BOARD LOCATION
BT2501	5K	7D	J2502	1B	2K	R2516	7D	6G	U2502	7A	6K
C2514	6B	6H	J2502	3M	2K	R2517	8F	6K	U2503A	2F	4H
C2515	6B	6H	Q2507	7F	7K	R2518	8F	6K	U2503B	2D	4H
C2516	5J	8K				R2519	6J	6K	U2503C	8G	4H
C2517	8A	6K	R2501	2D	4G	R2520	5H	4J	U2503D	1F	4H
C2518	8A	8K	R2502	1D	4H	R2521	5E	5J	U2506A	7D	5K
C2551	4M	4F	R2503	7E	5K	R2522	3H	6J	U2506B	7D	5K
C2552	4M	4F	R2504	6B	5K	R2523	7A	6K	U2506C	7B	5K
C2553	3M	4F	R2505	8D	5F	R2524	8B	6K	U2506D	2E	5K
C2554	3M	4F	R2506	5K	7C	R2526	7D	6F	U2512	3J	4F
C2555	5M	4K	R2507	6D	6H	R2527	7D	6G	U2513	3G	4J
			R2508	2B	3D	R2554	2B	2A	U2514	2G	5H
CR2501	4J	7K	R2509	1B	5K	R2555	1B	4G	U2515	1E	4H
CR2502	4K	7K	R2510	2B	8J	R2560	3M	4F	U2517	4L	5F
CR2504	8E	6K	R2511	1B	8C	R2561	3M	4F	U2518	5L	4K
CR2505	7F	7K	R2512	1E	4H	R2562	3M	4F	U2519	6L	6J
			R2513	1D	4G	R2563	4M	4F	U2521	7J	5J
DS2501	8E	7K	R2514	3D	5G	R2564	5M	4K			
			R2515	8D	6G	U2501	1C	6G	Y2501	6C	6H

Partial A16 also shown on diagrams 9, 10, 11, 12 and 16.

A B C D E F G H J K L M N

1
2
3
4
5
6
7
8

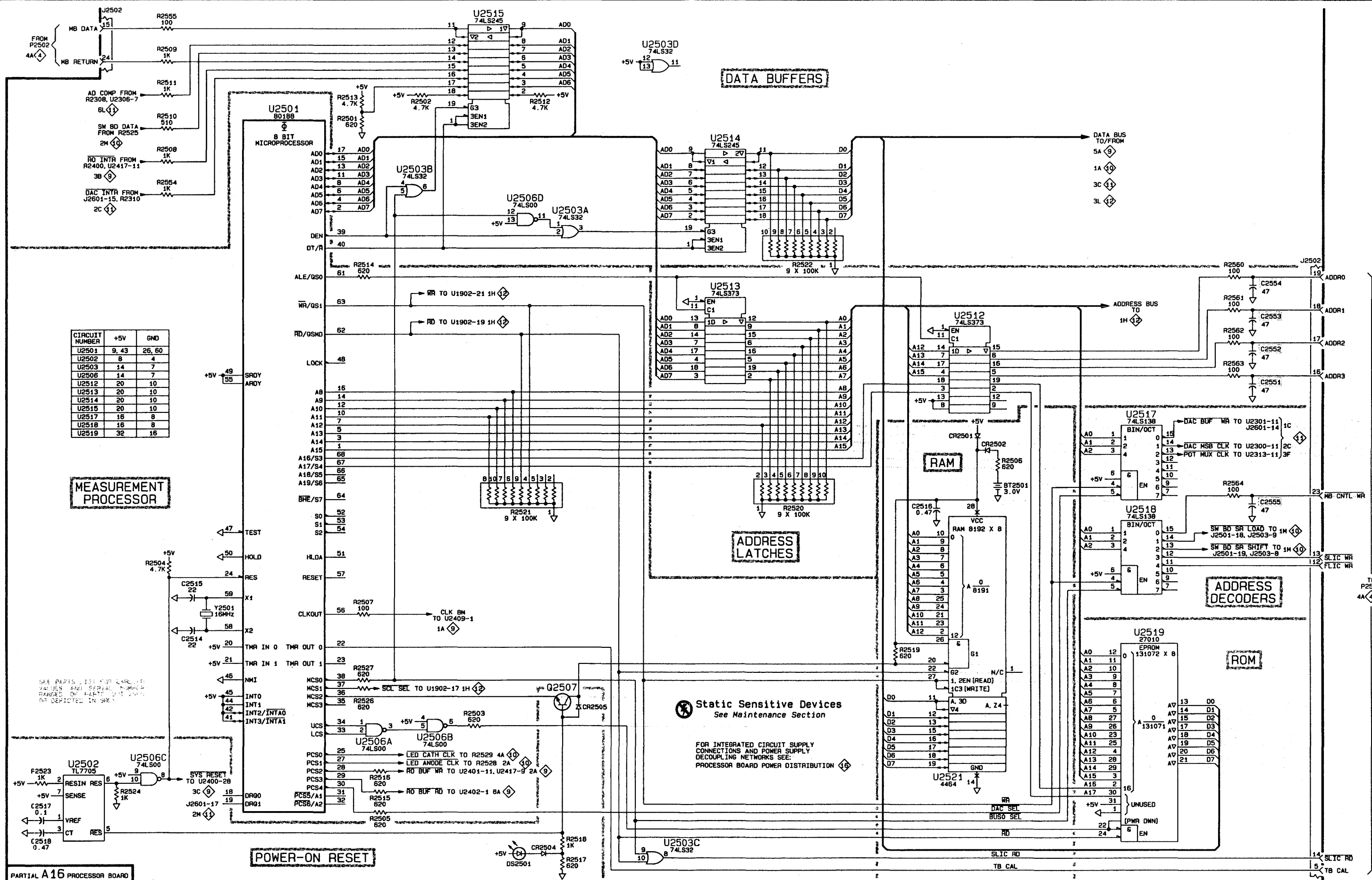

CIRCUIT NUMBER	+5V	GND
U2501	9, 43	26, 60
U2502	8	4
U2503	14	7
U2506	14	7
U2512	20	10
U2513	20	10
U2514	20	10
U2515	20	10
U2517	16	8
U2518	16	8
U2519	32	16

MEASUREMENT PROCESSOR

POWER-ON RESET

⊗ Static Sensitive Devices
See Maintenance Section

FOR INTEGRATED CIRCUIT SUPPLY CONNECTIONS AND POWER SUPPLY DECOUPLING NETWORKS SEE: PROCESSOR BOARD POWER DISTRIBUTION

PARTIAL A16 PROCESSOR BOARD

2247A

8367-08
REV MAR 1990

MEASUREMENT PROCESSOR

8

WAVEFORMS FOR DIAGRAM 9

STORE/RECALL MENU ON FACTORY
RECALL #1 SELECTED

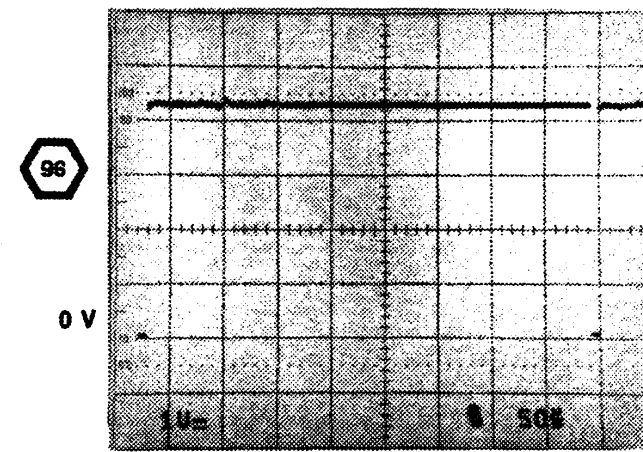
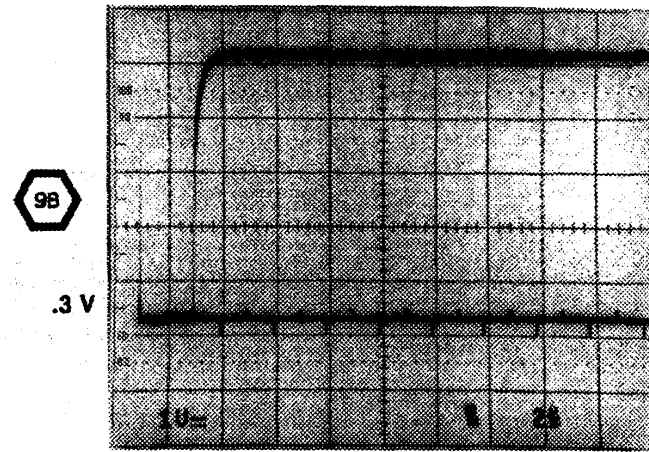
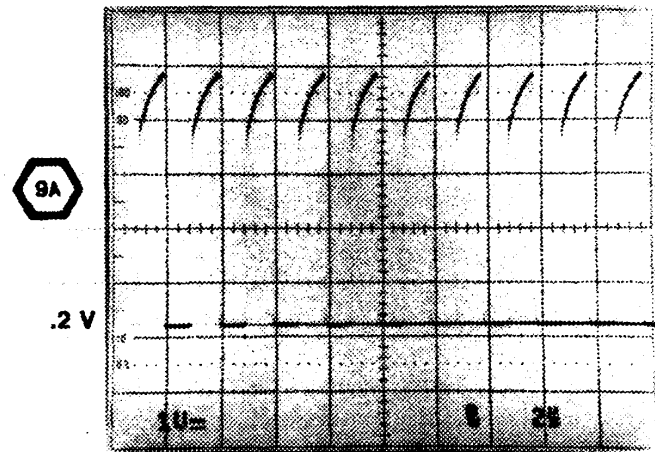

6555-72

STORE/RECALL MENU
ON FACTORY RECALL #1 SELECTED

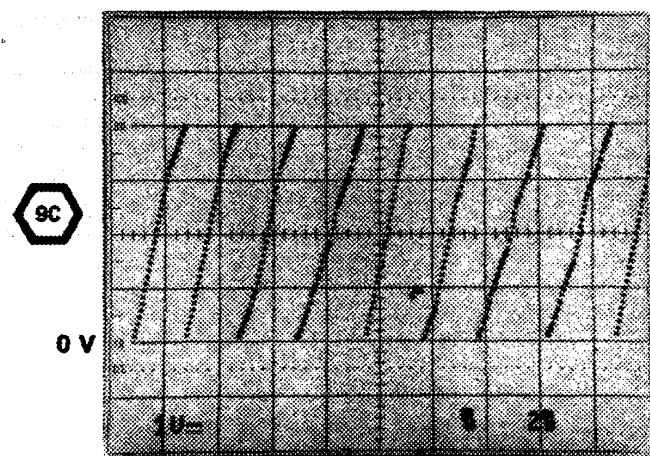

STORE/RECALL MENU
ON FACTORY RECALL #1 SELECTED

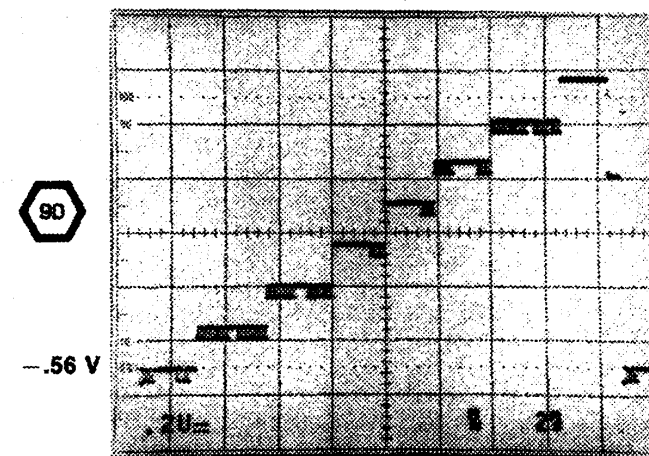

FACTORY SETUP #1 MENU OFF.

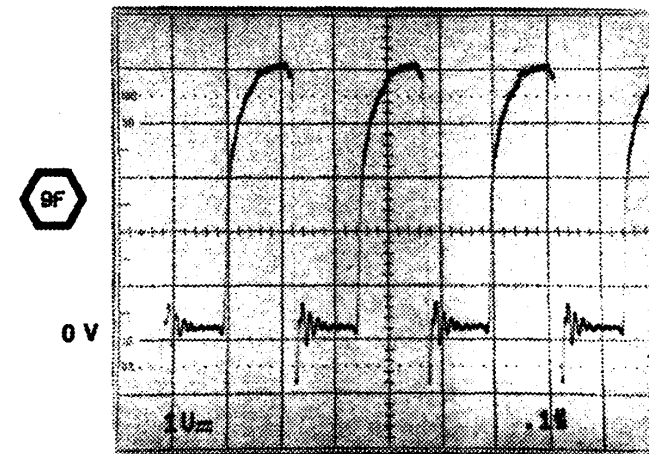
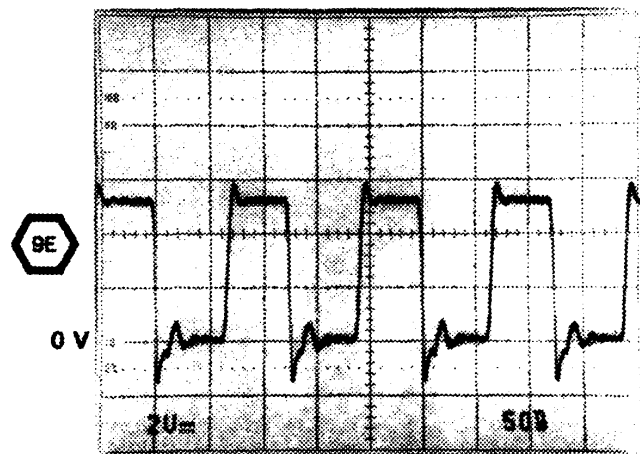

READOUT SYSTEM DIAGRAM 9

ASSEMBLY A16											
CIRCUIT NUMBER	SCHEM LOCATION	BOARD LOCATION	CIRCUIT NUMBER	SCHEM LOCATION	BOARD LOCATION	CIRCUIT NUMBER	SCHEM LOCATION	BOARD LOCATION	CIRCUIT NUMBER	SCHEM LOCATION	BOARD LOCATION
C2411	6J	5E	R2404	1G	1D	R2420	2M	2A	U2410	2E	2B
C2412	4J	5D	R2405	4G	5D	R2421	1A	2C	U2411	7F	4B
C2416	2H	1B	R2406	5K	6E				U2412	4J	5D
C2417	2J	1B	R2407	5K	6E	U2400	2C	3C	U2413	3J	5C
C2418	2J	1B	R2408	3K	6C	U2401	4B	5E	U2414	4L	6D
C2419	2J	1B	R2409	3K	6C	U2402	6B	5E	U2415	3L	6C
C2420	2K	1B	R2410	5M	7C	U2403	1G	1C	U2416A	5L	7C
			R2411	3M	7C	U2404	5E	4B	U2416B	3L	7C
J2302	3M	8B	R2413	5J	5E	U2405	6F	3B	U2416C	3M	7C
J2502	1A	2K	R2414	6J	5E	U2406	5G	4C	U2416D	5M	7C
J2502	1M	2K	R2415	4J	5D	U2407A	4F	5E	U2417A	1B	1A
			R2416	4J	5C	U2407B	3F	5E	U2417B	1C	1A
R2400	2B	2A	R2417	4M	7C	U2408	4G	5C	U2417C	2B	1A
R2401	2M	2A	R2418	4M	7C	U2409A	1B	2B	U2417D	3B	1A
R2402	2F	2C	R2419	2M	2C	U2409B	1D	2B			

Partial A16 also shown on diagrams 8, 10, 11, 12 and 16.

A B C D E F G H J K L M N

1
2
3
4
5
6
7
8

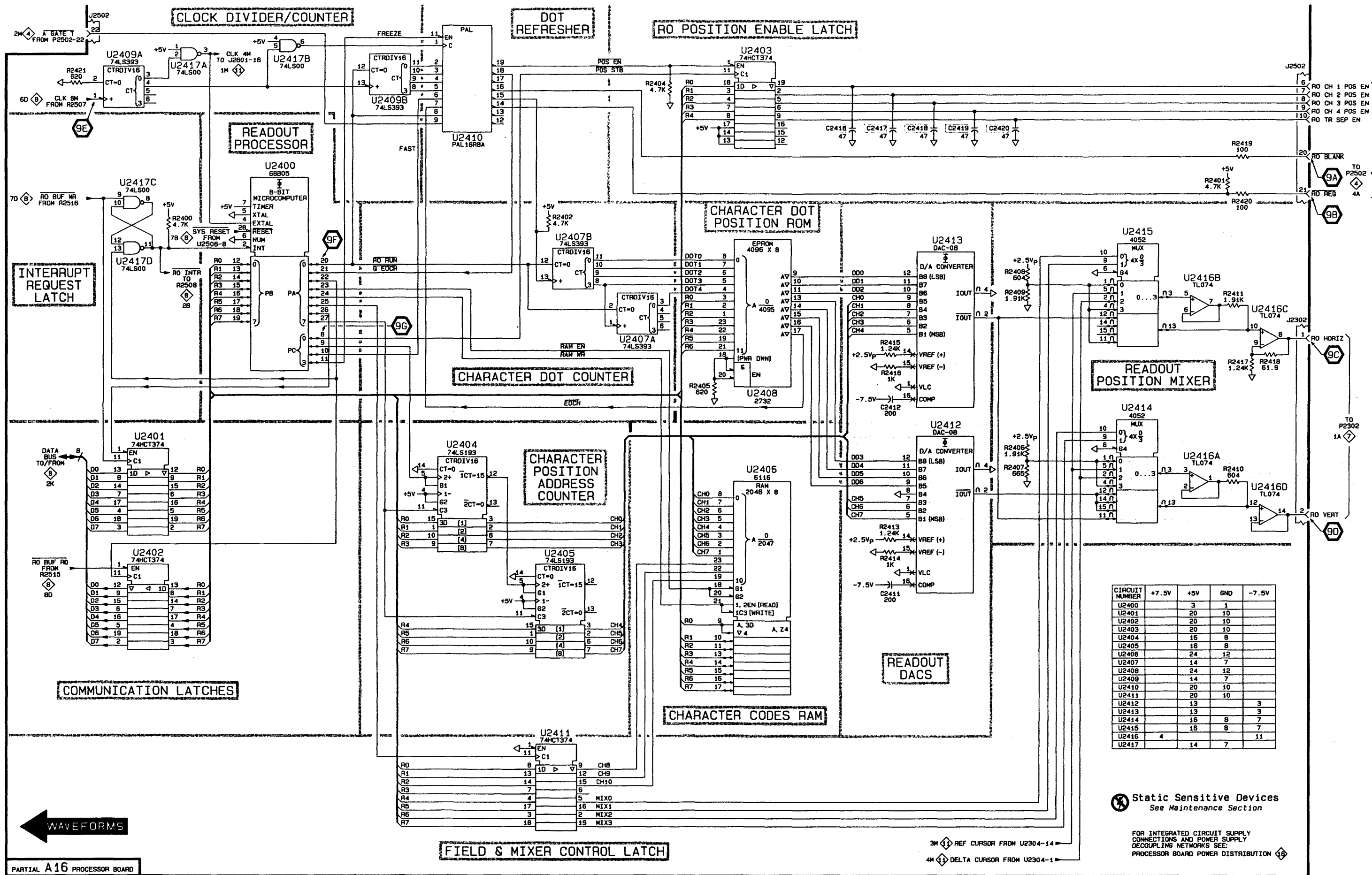

CIRCUIT NUMBER	+7.5V	+5V	GND	-7.5V
U2400	3	1		
U2401	20	10		
U2402	20	10		
U2403	20	10		
U2404	16	8		
U2405	16	8		
U2406	24	12		
U2407	14	7		
U2408	24	12		
U2409	14	7		
U2410	20	10		
U2411	20	10		
U2412	13		3	
U2413	13		3	
U2414	16	8	7	
U2415	16	8	7	
U2416	4		11	

⊗ Static Sensitive Devices
See Maintenance Section

FOR INTEGRATED CIRCUIT SUPPLY CONNECTIONS AND POWER SUPPLY DECOUPLING NETWORKS SEE PROCESSOR BOARD POWER DISTRIBUTION

3M REF CURSOR FROM U2304-14
4M DELTA CURSOR FROM U2304-1

PARTIAL A16 PROCESSOR BOARD

2247A

6367-09
REV MAR 1990

READOUT SYSTEM

9

WAVEFORMS

FIELD & MIXER CONTROL LATCH

READOUT DACS

CHARACTER CODES RAM

CHARACTER POSITION ADDRESS COUNTER

CHARACTER DOT COUNTER

CHARACTER DOT POSITION ROM

READOUT POSITION MIXER

READOUT PROCESSOR

RO POSITION ENABLE LATCH

DOT REFRESHER

CLOCK DIVIDER/COUNTER

INTERRUPT REQUEST LATCH

COMMUNICATION LATCHES

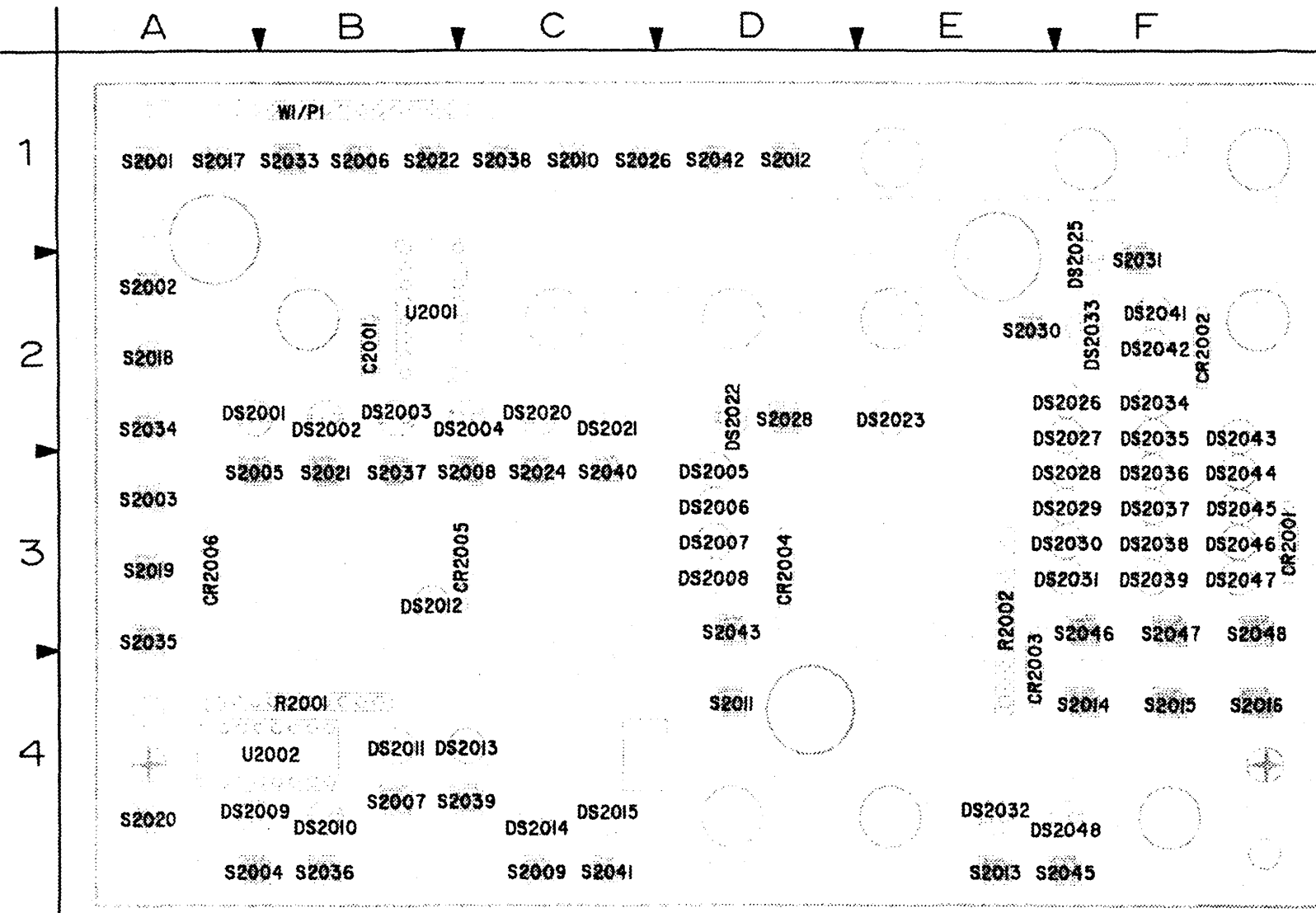

6081-37

Figure 9-9. A14—Switch board.

A14—SWITCH BOARD							
CIRCUIT NUMBER	SCHEM NUMBER	CIRCUIT NUMBER	SCHEM NUMBER	CIRCUIT NUMBER	SCHEM NUMBER	CIRCUIT NUMBER	SCHEM NUMBER
C2001	16	DS2023	10	R2001	10	S2026	10
CR2001	10	DS2025	10	R2002	10	S2028	10
CR2002	10	DS2026	10			S2030	10
CR2003	10	DS2027	10	S2001	10	S2031	10
CR2004	10	DS2028	10	S2002	10	S2033	10
CR2005	10	DS2029	10	S2003	10	S2034	10
CR2006	10	DS2030	10	S2004	10	S2035	10
		DS2031	10	S2005	10	S2036	10
		DS2032	10	S2006	10	S2037	10
DS2001	10	DS2033	10	S2007	10	S2038	10
DS2002	10	DS2034	10	S2008	10	S2039	10
DS2003	10	DS2035	10	S2009	10	S2040	10
DS2004	10	DS2036	10	S2010	10	S2041	10
DS2005	10	DS2037	10	S2011	10	S2042	10
DS2006	10	DS2038	10	S2012	10	S2043	10
DS2007	10	DS2039	10	S2013	10	S2044	10
DS2008	10	DS2040	10	S2014	10	S2045	10
DS2009	10	DS2041	10	S2015	10	S2046	10
DS2010	10	DS2042	10	S2016	10	S2047	10
DS2011	10	DS2043	10	S2017	10	S2048	10
DS2012	10	DS2044	10	S2018	10	U2001	10
DS2013	10	DS2045	10	S2019	10	U2001	16
DS2014	10	DS2046	10	S2020	10	U2002	10
DS2015	10	DS2047	10	S2021	10	U2002	16
DS2016	10	DS2048	10	S2022	10	W2501	10
DS2017	10	P2501	10	S2024	10	W2501	16
DS2018	10	P2501	16				

⊗ Static Sensitive Devices
See Maintenance Section

COMPONENT NUMBER EXAMPLE

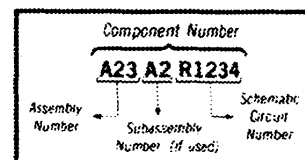

Chassis-mounted components have no Assembly Number prefix—see end of Replaceable Electrical Parts List

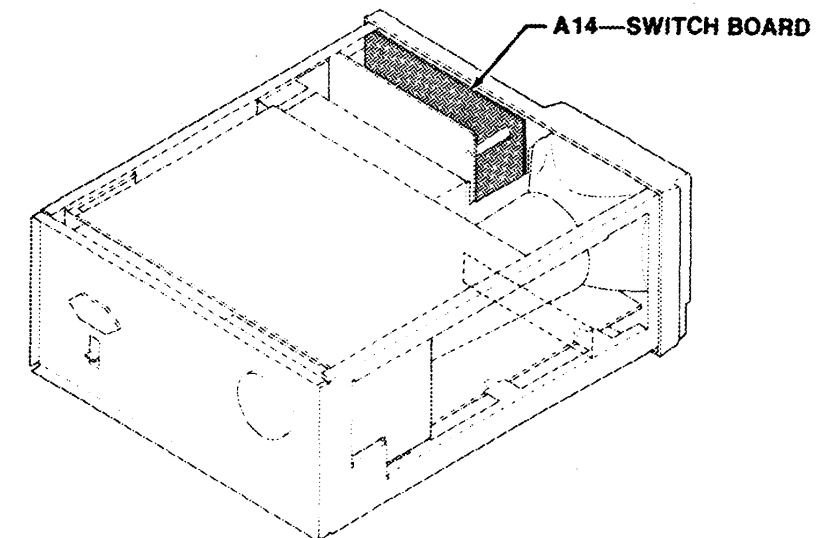

WAVEFORMS FOR DIAGRAM 10

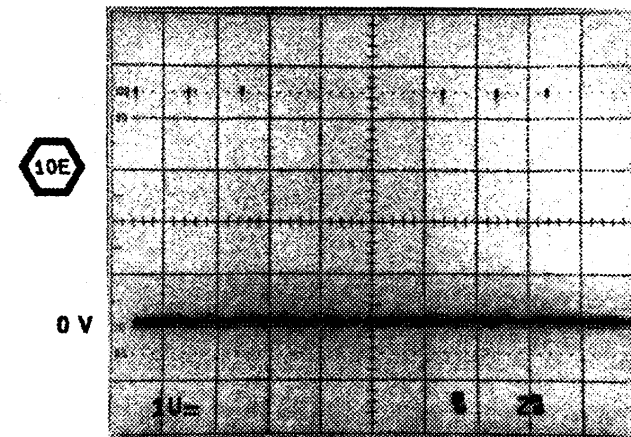
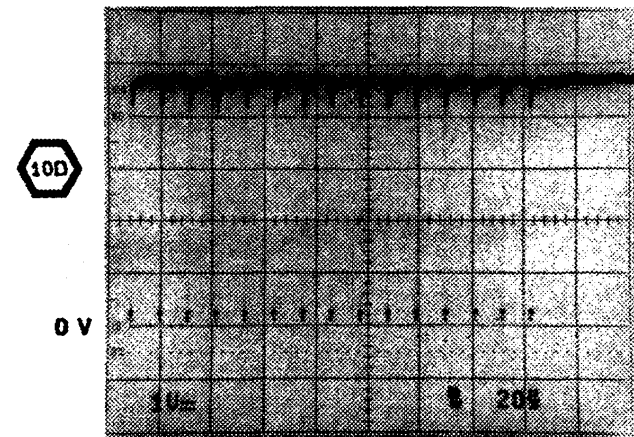
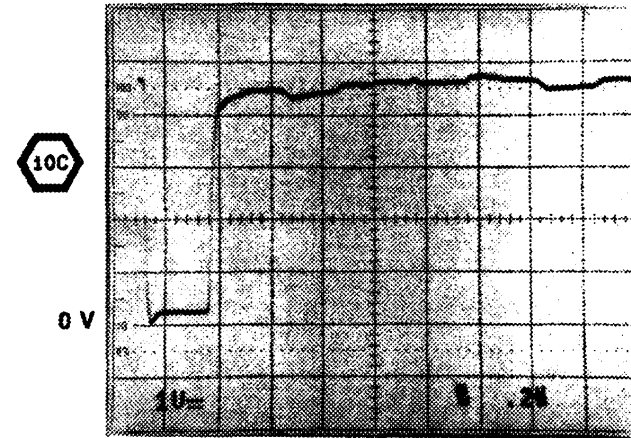
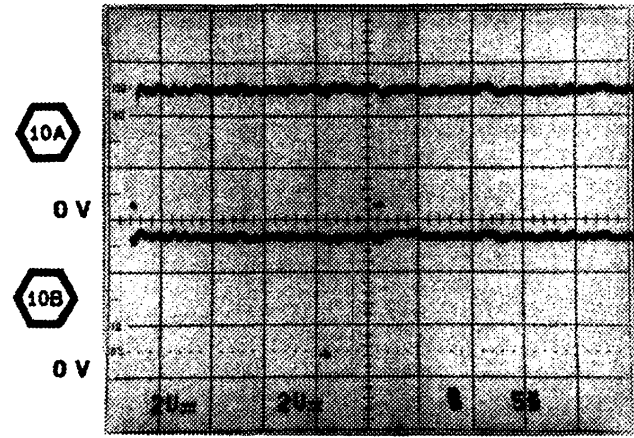

SWITCH BOARD AND INTERFACE DIAGRAM 10

ASSEMBLY A14											
CIRCUIT NUMBER	SCHEM LOCATION	BOARD LOCATION	CIRCUIT NUMBER	SCHEM LOCATION	BOARD LOCATION	CIRCUIT NUMBER	SCHEM LOCATION	BOARD LOCATION	CIRCUIT NUMBER	SCHEM LOCATION	BOARD LOCATION
CR2001	3G	3F	DS2025	3D	2F	R2001	7L	4B	S2024	8H	3C
CR2002	3G	2F	DS2026	3D	2F	R2002	4L	3E	S2026	5H	1C
CR2003	3H	4E	DS2027	4D	2F				S2028	4H	2D
CR2004	3J	3D	DS2028	5D	3F	S2001	8J	1A	S2030	3H	2E
CR2005	3J	3C	DS2029	5D	3F	S2002	8J	2A	S2031	3H	2F
CR2006	3K	3A	DS2030	6D	3F	S2003	7J	3A	S2033	8G	1B
			DS2031	7D	3F	S2004	7J	4A	S2034	8G	2A
DS2001	3F	2A	DS2032	8E	4E	S2005	7J	3A	S2035	8G	3A
DS2002	3F	2B	DS2033	3D	2F	S2006	6J	1B	S2036	7G	4B
DS2003	4F	2B	DS2034	3D	2F	S2007	6J	4B	S2037	7G	3B
DS2004	5F	2C	DS2035	4D	2F	S2008	6J	3C	S2038	6G	1C
DS2005	6F	3D	DS2036	5D	3F	S2009	5J	4C	S2039	6G	4C
DS2006	6F	3D	DS2037	6D	3F	S2010	5J	1C	S2040	6G	3C
DS2007	7F	3D	DS2038	6D	3F	S2011	4J	4D	S2041	5G	4C
DS2008	8F	3D	DS2039	7D	3F	S2012	4J	1D	S2042	5G	1D
DS2009	3F	4A	DS2041	3C	2F	S2013	4J	4E	S2043	5G	3D
DS2010	3F	4B	DS2042	3C	2F	S2014	3J	4F	S2045	4G	4F
DS2011	4F	4B	DS2043	4C	2F	S2015	3J	4F	S2046	3G	3F
DS2012	5F	3B	DS2044	5C	3F	S2016	3J	4F	S2047	3G	3F
DS2013	6F	4C	DS2045	6C	3F	S2017	8H	1A	S2048	3G	3F
DS2014	6F	4C	DS2046	6C	3F	S2018	8H	2A			
DS2015	7F	4C	DS2047	7C	3F	S2019	7H	3A	U2001	2M	2B
DS2020	5E	2C	DS2048	8C	4F	S2020	7H	4A	U2002	5M	4B
DS2021	6E	2C				S2021	7H	3B			
DS2022	6E	2D	P2501	2F	1B	S2022	6H	1B	W2501	2M	1B
DS2023	7E	2E	P2501	3C	1B				W2501	8C	1B

Partial A14 also shown on diagram 16.

ASSEMBLY A16											
C2521	2F	7H	C2549	7B	7K	Q2506	1K	7H	R2547	4C	7J
C2522	1G	7H	C2550	8B	8J				R2548	4C	7J
C2523	1H	7H				R2525	1M	8J	R2549	5B	7J
C2524	1J	7H	J2501	2F	8J	R2528	2A	6H	R2550	6B	7J
C2525	1J	7H	J2501	3C	8J	R2529	4A	6H	R2551	7B	7J
C2526	1K	7G	J2503	1M	7K	R2532	2F	7H	R2552	7B	7K
C2543	3C	7H				R2534	1G	7H	R2553	8B	7J
C2544	4C	7J	Q2501	2G	7J	R2536	1H	7H			
C2545	4C	7J	Q2502	1H	7J	R2538	1J	7H	U2523	1A	7H
C2546	5B	7J	Q2503	1H	7H	R2540	1J	7H	U2524	3A	6J
C2547	6B	7J	Q2504	1J	7H	R2542	1K	7G	U2525	3B	7J
C2548	7B	7J	Q2505	1K	7H	R2546	3B	7J			

Partial A16 also shown on diagrams 8, 9, 11, 12 and 16.

A B C D E F G H J K L M N

1
2
3
4
5
6
7
8

LED ANODE AND SWITCH REGISTER

LED & SWITCH COLUMN DRIVERS

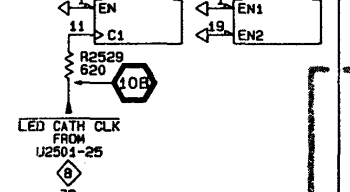
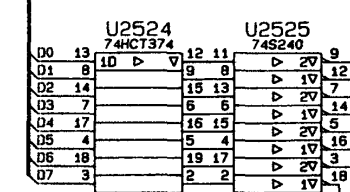
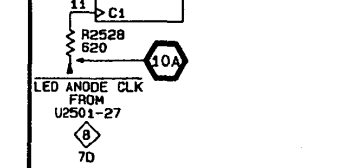
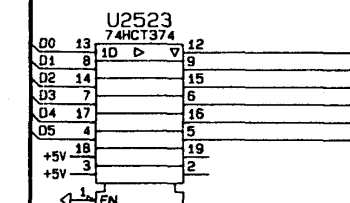

LED CATHODE REGISTER & DRIVER

CIRCUIT NUMBER	+5V	GND
U2001	16	8
U2523	20	10
U2524	20	10
U2525	20	10

WAVEFORMS

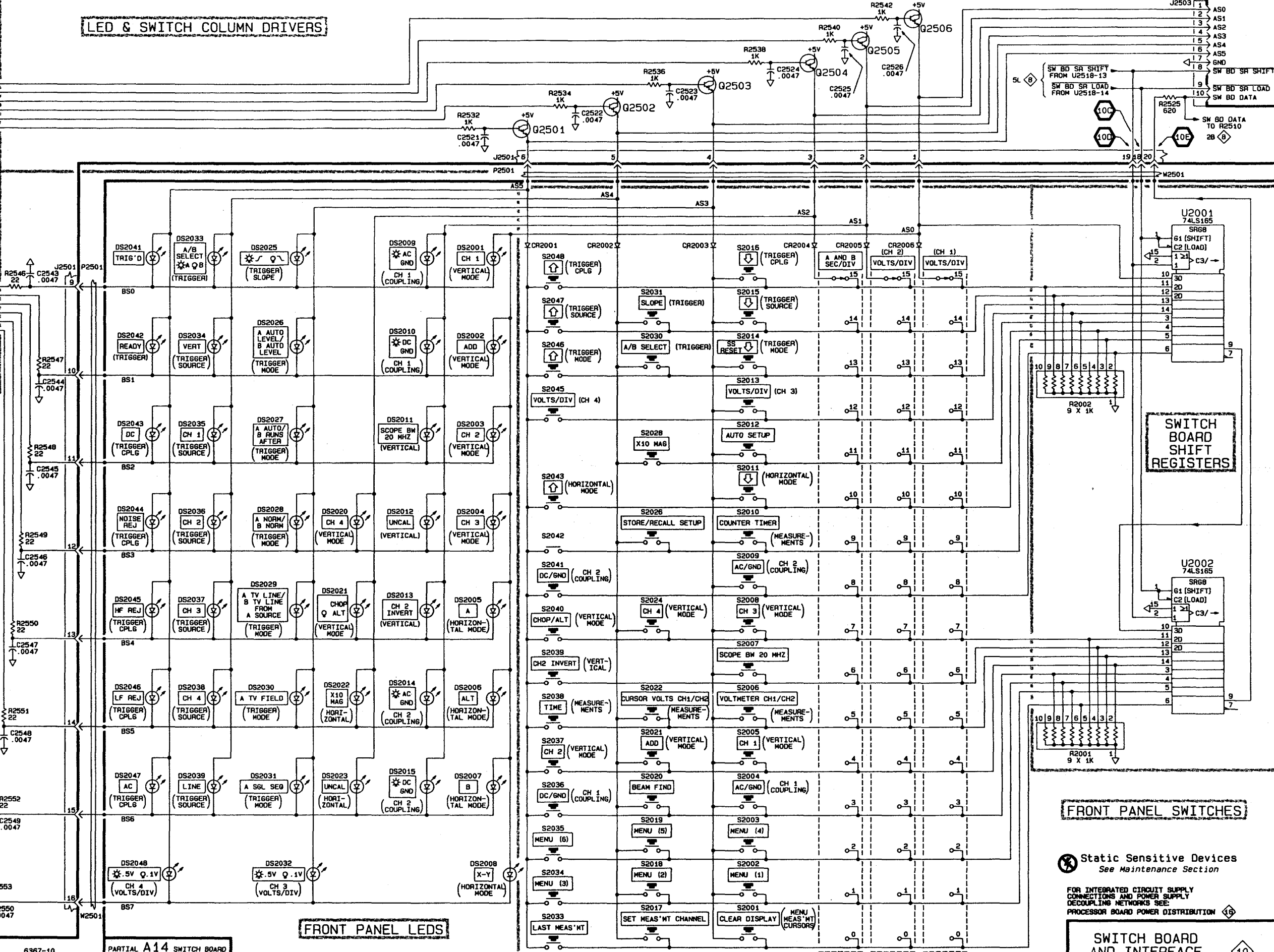

SWITCH BOARD SHIFT REGISTERS

SWITCH BOARD SHIFT REGISTERS

FRONT PANEL SWITCHES

⚡ Static Sensitive Devices
See Maintenance Section

FOR INTEGRATED CIRCUIT SUPPLY CONNECTIONS AND POWER SUPPLY DECOUPLING NETWORKS SEE: PROCESSOR BOARD POWER DISTRIBUTION

SWITCH BOARD AND INTERFACE

PARTIAL A16 PROCESSOR BOARD

2247A

6367-10

PARTIAL A14 SWITCH BOARD

FRONT PANEL LEDES

10

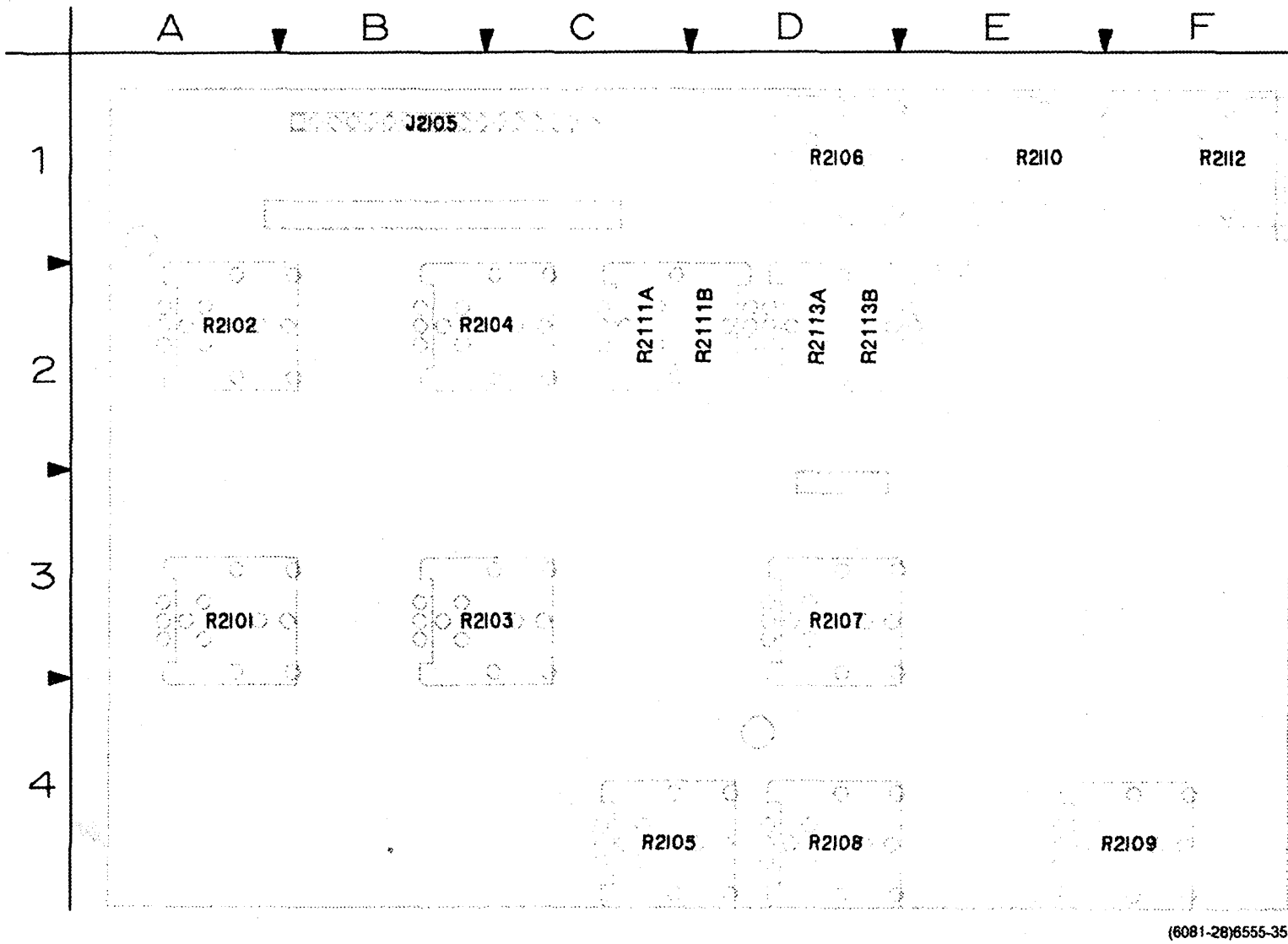

(6081-28)8555-35

Figure 9-10. A12—Potentiometer board.

A12—POT BOARD					
CIRCUIT NUMBER	SCHEM NUMBER	CIRCUIT NUMBER	SCHEM NUMBER	CIRCUIT NUMBER	SCHEM NUMBER
J2105	11	R2104	11	R2110	11
J2105	16	R2105	11	R2111	11
		R2106	11	R2112	11
R2101	11	R2107	11	R2113	11
R2102	11	R2108	11		
R2103	11	R2109	11		

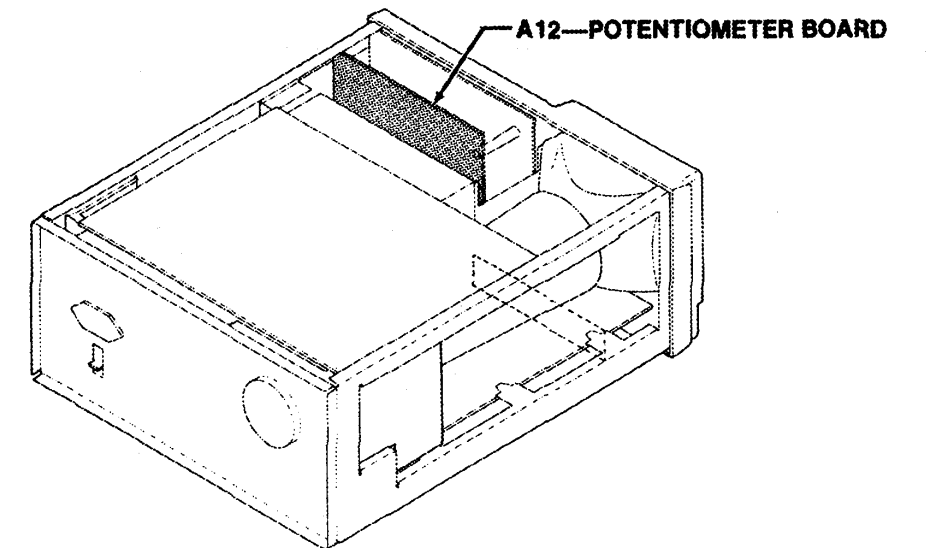

 Static Sensitive Devices
See Maintenance Section

COMPONENT NUMBER EXAMPLE

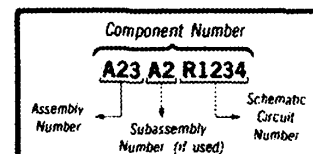

Chassis-mounted components have no Assembly Number prefix—see end of Replaceable Electrical Parts List.

WAVEFORMS FOR DIAGRAM 11

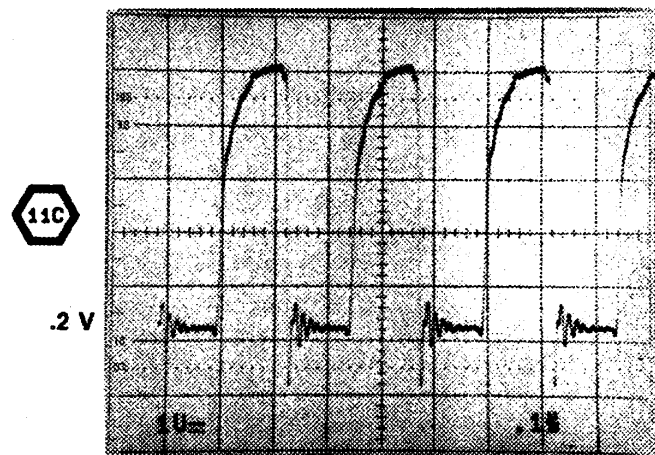
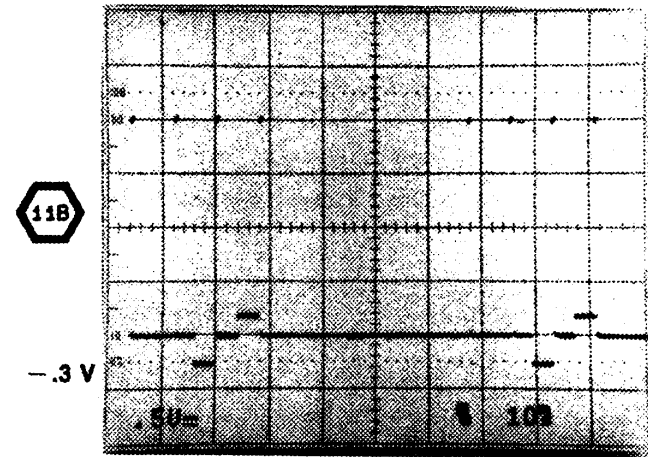
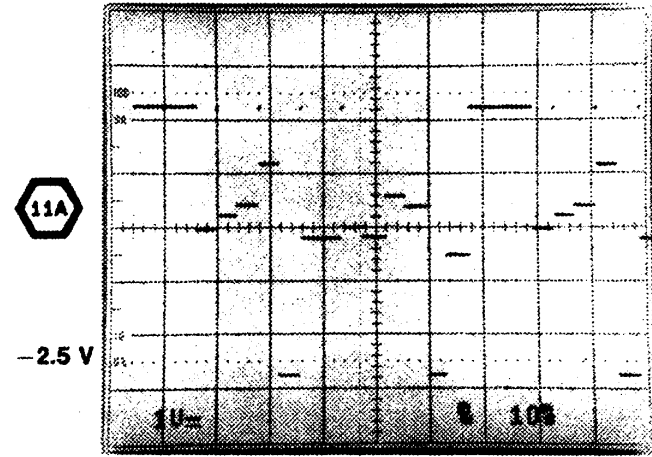

ADC, DAC SYSTEM DIAGRAM 11

ASSEMBLY A12											
CIRCUIT NUMBER	SCHEM LOCATION	BOARD LOCATION	CIRCUIT NUMBER	SCHEM LOCATION	BOARD LOCATION	CIRCUIT NUMBER	SCHEM LOCATION	BOARD LOCATION	CIRCUIT NUMBER	SCHEM LOCATION	BOARD LOCATION
J2105	4B	1B	R2104	6A	2B	R2108	8A	4D	R2111B	3B	2D
R2101	6A	3A	R2105	7A	4C	R2109	6A	4F	R2112	5A	1F
R2102	8A	2A	R2106	3A	1D	R2110	5A	1E	R2113A	4B	2D
R2103	7A	3B	R2107	4A	3D	R2111A	3A	2C	R2113B	4A	2E
<i>Partial A12 also shown on diagram 16.</i>											
ASSEMBLY A16											
C2300	3H	7B	R2302	3H	7A	R2330	2G	6A	R2363	7L	7F
C2301	3L	7C	R2303	2J	6C	R2331	2G	6A	R2364	6K	7F
C2302	4L	7B	R2304	3L	7A	R2337	4F	7G	R2365	7L	7F
C2303	3L	7B	R2305	4L	7B	R2338	4F	7G			
C2305	2L	7B	R2306	6K	7C	R2339	4F	7G	U2300	2D	5B
C2306	2M	7B	R2307	5K	7C	R2340	4F	7G	U2301	1E	5B
C2307	3L	7A	R2308	5K	7C	R2341	4F	7G	U2302	3J	6B
C2308	3M	7A	R2310	2C	2A	R2342	4F	7G	U2303	1K	6A
C2309	4L	7A	R2311	6F	7F	R2343	5H	7G	U2304A	4L	7B
C2310	4M	7B	R2312	6F	7F	R2344	4H	7G	U2304B	2M	7B
C2318	6K	7C	R2313	7E	7E	R2345	5E	7F	U2304C	3L	7B
C2320	5M	7D	R2314	7E	7E	R2346	5E	7G	U2304D	3L	7B
C2322	5M	7D	R2315	7F	7E	R2347	5E	7F	U2305A	5M	7B
C2323	5L	7D	R2316	7F	7E	R2348	5E	7F	U2305B	4M	7B
C2324	5M	7A	R2317	7E	7E	R2349	5E	7F	U2305C	3M	7B
			R2318	7E	7E	R2350	5H	7F	U2305D	2L	7B
J2302	2M	6B	R2319	1K	4A	R2351	5H	7F	U2306	5K	7C
J2304	6M	6E	R2320	1J	3A	R2352	6L	7E	U2308	5J	7G
J2601	1C	2A	R2321	1J	5A	R2355	8L	7D	U2309	6J	6G
J2601	1M	2A	R2322	1J	5A	R2356	8L	7D	U2313	3G	6E
			R2324	1C	5B	R2357	8L	7D	U2314	2J	6B
P2105	4B	6G	R2325	4E	6G	R2361	7K	7F			
			R2328	2F	6A	R2362	6K	7F	W2105	5B	8G
R2301	3H	7A	R2329	2F	6A						
<i>Partial A16 also shown on diagrams 8, 9, 10, 12 and 16.</i>											

A B C D E F G H J K L M N

1
2
3
4
5
6
7
8

← WAVEFORMS

INPUT DATA LATCHES

D/A CONVERTER

POT MUX LATCH

FRONT PANEL CONTROL MUX

SAMPLE & HOLD

CIRCUIT NUMBER	+7.5V	+5V	GND	-7.5V	-15V
U2300	20	10			
U2301	20	10			
U2302	20	13			17
U2303	4	16	8	7	
U2304	4			11	
U2305	4			11	
U2306	8	1	4		
U2308	16	8	7		
U2309	16	8	7		
U2313	7	20	10	4	

⚡ Static Sensitive Devices
See Maintenance Section

FOR INTEGRATED CIRCUIT SUPPLY CONNECTIONS AND POWER SUPPLY DECOUPLING NETWORKS SEE: PROCESSOR BOARD POWER DISTRIBUTION

SEE PARTS LIST FOR EARLIER VALUES AND SERIAL NUMBER RANGES OF PARTS OUTLINED OR DEPICTED IN GREY.

2247A

6367-11
REV MAR 1990

ADC, DAC SYSTEM

11

ADC, DAC SYSTEM DIAGRAM 11

ASSEMBLY A12											
CIRCUIT NUMBER	SCHEM LOCATION	BOARD LOCATION	CIRCUIT NUMBER	SCHEM LOCATION	BOARD LOCATION	CIRCUIT NUMBER	SCHEM LOCATION	BOARD LOCATION	CIRCUIT NUMBER	SCHEM LOCATION	BOARD LOCATION
J2105	4B	1B	R2104	6A	2B	R2108	8A	4D	R2111B	3B	2D
R2101	6A	3A	R2105	7A	4C	R2109	6A	4F	R2112	5A	1F
R2102	8A	2A	R2106	3A	1D	R2110	5A	1E	R2113A	4B	2D
R2103	7A	3B	R2107	4A	3D	R2111A	3A	2C	R2113B	4A	2E

Partial A12 also shown on diagram 16.

ASSEMBLY A16											
CIRCUIT NUMBER	SCHEM LOCATION	BOARD LOCATION	CIRCUIT NUMBER	SCHEM LOCATION	BOARD LOCATION	CIRCUIT NUMBER	SCHEM LOCATION	BOARD LOCATION	CIRCUIT NUMBER	SCHEM LOCATION	BOARD LOCATION
C2300	3H	7B	R2302	3H	7A	R2330	2G	6A	R2363	7L	7F
C2301	3L	7C	R2303	2J	6C	R2331	2G	6A	R2364	8K	7F
C2302	4L	7B	R2304	3L	7A	R2337	4F	7G	R2365	7L	7F
C2303	3L	7B	R2305	4L	7B	R2338	4F	7G			
C2305	2L	7B	R2306	6K	7C	R2339	4F	7G	U2300	2D	5B
C2306	2M	7B	R2307	5K	7C	R2340	4F	7G	U2301	1E	5B
C2307	3L	7A	R2308	5K	7C	R2341	4F	7G	U2302	3J	6B
C2308	3M	7A	R2310	2C	2A	R2342	4F	7G	U2303	1K	6A
C2309	4L	7A	R2311	6F	7F	R2343	5H	7G	U2304A	4L	7B
C2310	4M	7B	R2312	6F	7F	R2344	4H	7G	U2304B	2M	7B
C2318	6K	7C	R2313	7E	7E	R2345	5E	7F	U2304C	3L	7B
C2320	5M	7D	R2314	7E	7E	R2346	5E	7G	U2304D	3L	7B
C2322	5M	7D	R2315	7F	7E	R2347	5E	7F	U2305A	5M	7B
C2323	5L	7D	R2316	7F	7E	R2348	5E	7F	U2305B	4M	7B
C2324	5M	7A	R2317	7E	7E	R2349	5E	7F	U2305C	3M	7B
			R2318	7E	7E	R2350	5H	7F	U2305D	2L	7B
J2302	2M	8B	R2319	1K	4A	R2351	5H	7F	U2306	5K	7C
J2304	6M	8E	R2320	1J	3A	R2352	6L	7E	U2308	5J	7G
J2601	1C	2A	R2321	1J	5A	R2355	8L	7D	U2309	6J	6G
J2601	1M	2A	R2322	1J	5A	R2356	8L	7D	U2313	3G	6E
			R2324	1C	5B	R2357	8L	7D	U2314	2J	6B
P2105	4B	8G	R2325	4E	8G	R2361	7K	7F			
			R2328	2F	6A	R2362	6K	7F	W2105	5B	8G
R2301	3H	7A	R2329	2F	6A						

Partial A16 also shown on diagrams 8, 9, 10, 12 and 16.

WAVEFORMS FOR DIAGRAM 12

SET CH 1 VOLTS/DIV TO 1 V,
 SET A SEC/DIV TO 0.2 μ S,
 SELECT TOTALIZE FROM C/T MENU,
 APPLY 1 MHz, 3.5 V p-p SIGNAL TO CH 1,
 A SWEEP AND C/T STABLY TRIGGERED.

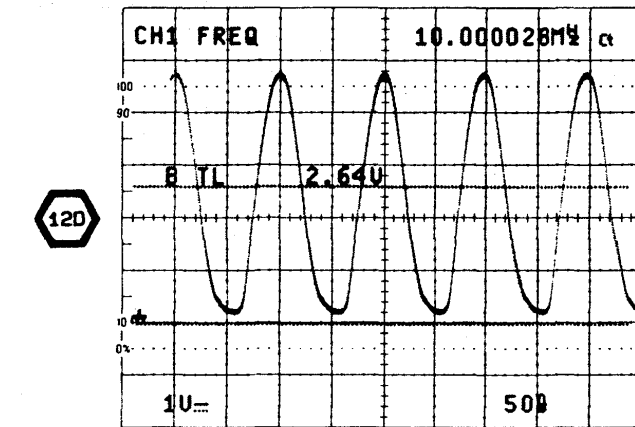
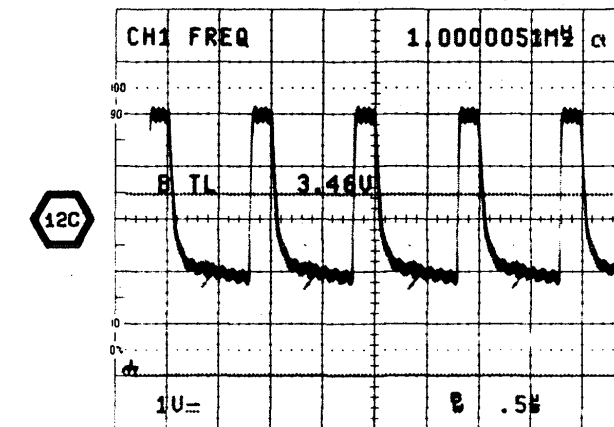
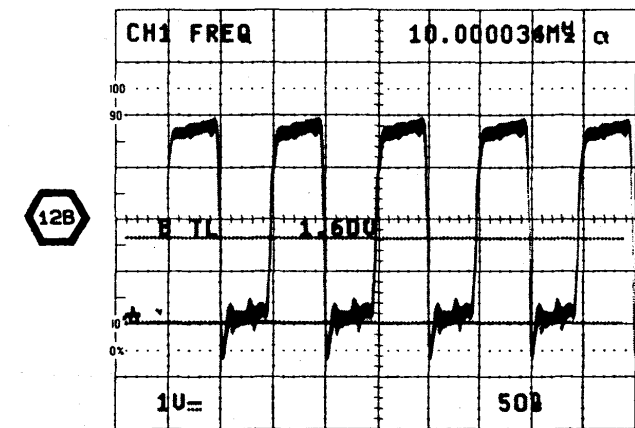
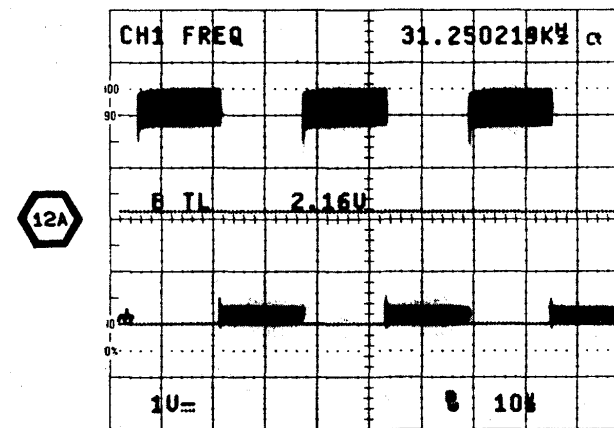

COUNTER/TIMER DIAGRAM 12

ASSEMBLY A16											
CIRCUIT NUMBER	SCHEM LOCATION	BOARD LOCATION	CIRCUIT NUMBER	SCHEM LOCATION	BOARD LOCATION	CIRCUIT NUMBER	SCHEM LOCATION	BOARD LOCATION	CIRCUIT NUMBER	SCHEM LOCATION	BOARD LOCATION
C1901*	8G	1G	Q1901*	8H	2G	R1923	4F	2G	R1949	4C	3J
C1902	8G	1G	Q1902	7H	2G	R1924	5F	2G	R1950	4C	3J
C1903	8H	1G	Q1903	7F	1J	R1925	5F	2G	R1951	3C	3J
C1904	8H	1G				R1926	6F	2H	R1952	3C	3J
C1905	7C	1G	R1901	7F	1G	R1927	6F	2G			
C1906	8E	1E	R1902	8F	1G	R1928	6G	1H	U1901A	8F	2F
C1907	6H	1H	R1903	7H	1G	R1929	6G	1H	U1901B	7L	2F
C1909	7H	2H	R1904	8G	1G	R1930	6H	2H	U1901C	8L	2F
C1910	7H	2H	R1905	8H	2G	R1931	7H	2H	U1901D	8L	2F
C1911	7H	1H	R1906	8E	1E	R1932	7H	2H	U1901	7C	2F
C1912	7G	2J	R1907	8E	1E	R1933	7H	2H	U1902	1J	2F
C1914	7F	1J	R1908	8F	1F	R1934	7H	2H	U1902	7D	2F
C1916	7E	2J	R1909	8F	1F	R1935	7G	2H	U1903A	3H	1H
C1917	7C	1J	R1910	8F	1F	R1936	7G	2H	U1903B	3H	1H
C1920	7C	2J	R1911	1G	3J	R1937	7F	1J	U1903C	4H	1H
			R1912	2H	3J	R1938	7F	1J	U1903D	4H	1H
CR1901	8E	1F	R1913	2G	3J	R1939	7E	2J	U1903	7C	1H
CR1902	8F	1F	R1914	2H	3J	R1940	7E	2J	U1904A	4H	2H
CR1903	7G	2J	R1915	2H	3H	R1941	4C	3J	U1904B	5H	2H
CR1904	6C	2K	R1916	2G	3H	R1942	4C	3J	U1904C	6H	2H
CR1905	6C	2K	R1917	3F	3H	R1943	3C	3K	U1904D	6H	2H
			R1918	1F	3H	R1944	3C	3J	U1904	7C	2H
J1901	2B	3K	R1919	4F	2G	R1945	2C	3K	U1905	1D	2J
J1902	8B	1E	R1920	3F	2G	R1946	3C	3J	U1905	7D	2J
			R1921	3F	2G	R1947	3C	3J			
L1901	7F	2J	R1922	3F	2G	R1948	3C	3K	Y1901	7G	1F

Partial A16 also shown on diagrams 8, 9, 10, 11 and 16.

OTHER PARTS											
J19	2B	CHASSIS	P601 P1901	2B 2B	CHASSIS CHASSIS	P1902	8B	CHASSIS	W601 W1902	8B 8B	CHASSIS CHASSIS

*See Parts List for serial number ranges.

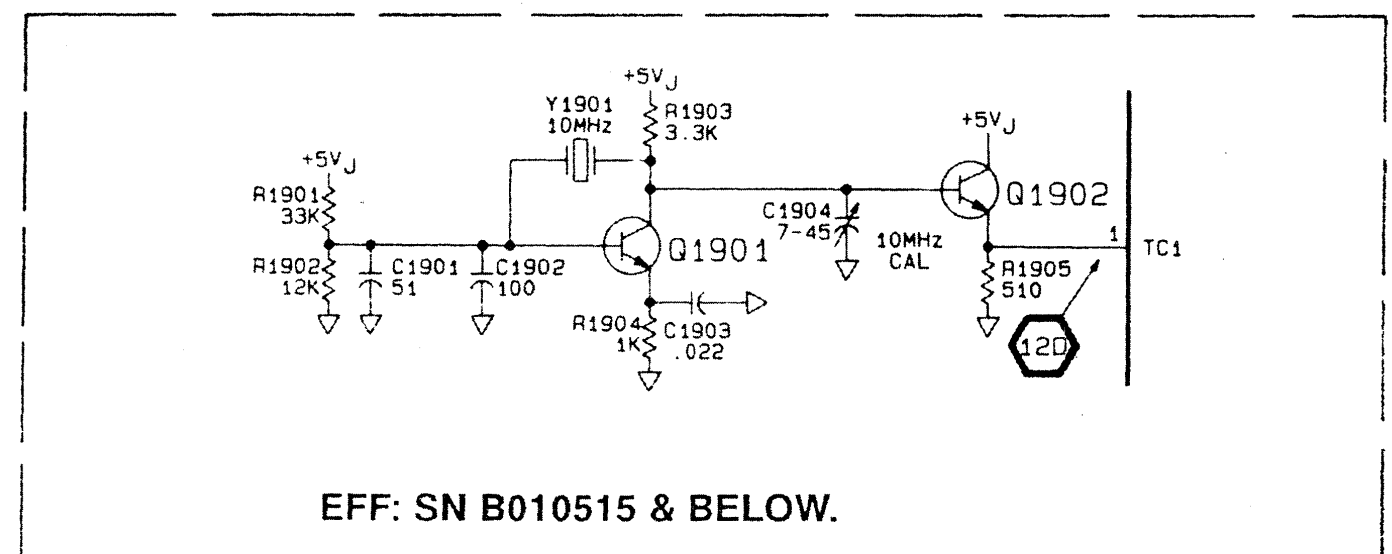

A B C D E F G H J K L M N

1
2
3
4
5
6
7
8

← WAVEFORMS

FAST COUNTER LOGIC

LEVEL TRANSLATORS

SLOW COUNTER LOGIC

TO/FROM J601 1M

← HISTORY

EXT COUNTER/TIMER TIMEBASE INPUT

EXTERNAL TIMEBASE INPUT

PARTIAL A16 PROCESSOR BOARD

COUNTER/TIMER

SEE PARTS LIST FOR EACH PER VALUE, AND SERIAL NUMBER RANGES OF PARTS OUTLINED OR DEPICTED IN GREY.

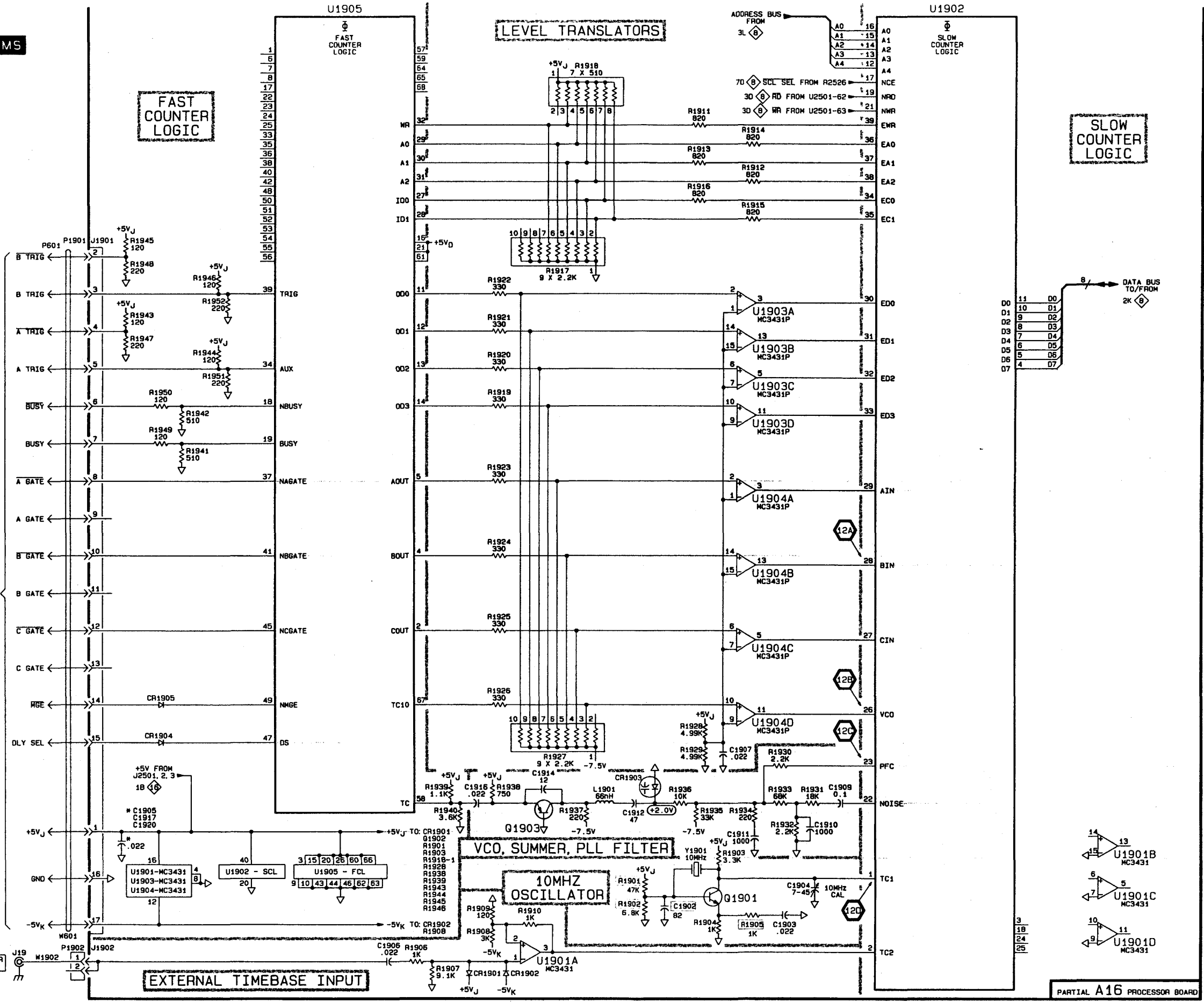

2247A

6367-12
REV MAR 1990

12

WAVEFORMS FOR DIAGRAM 13

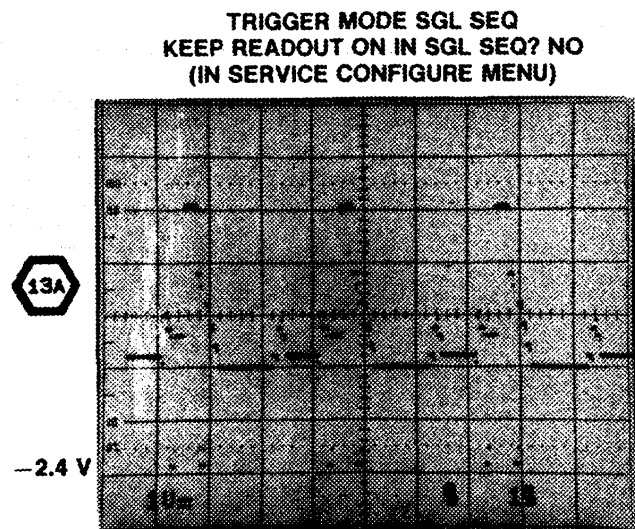

(6555-45)6367-26

Static Sensitive Devices
See Maintenance Section

COMPONENT NUMBER EXAMPLE

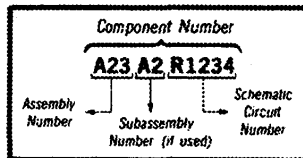

Chassis-mounted components have no Assembly Number prefix—see end of Replaceable Electrical Parts List.

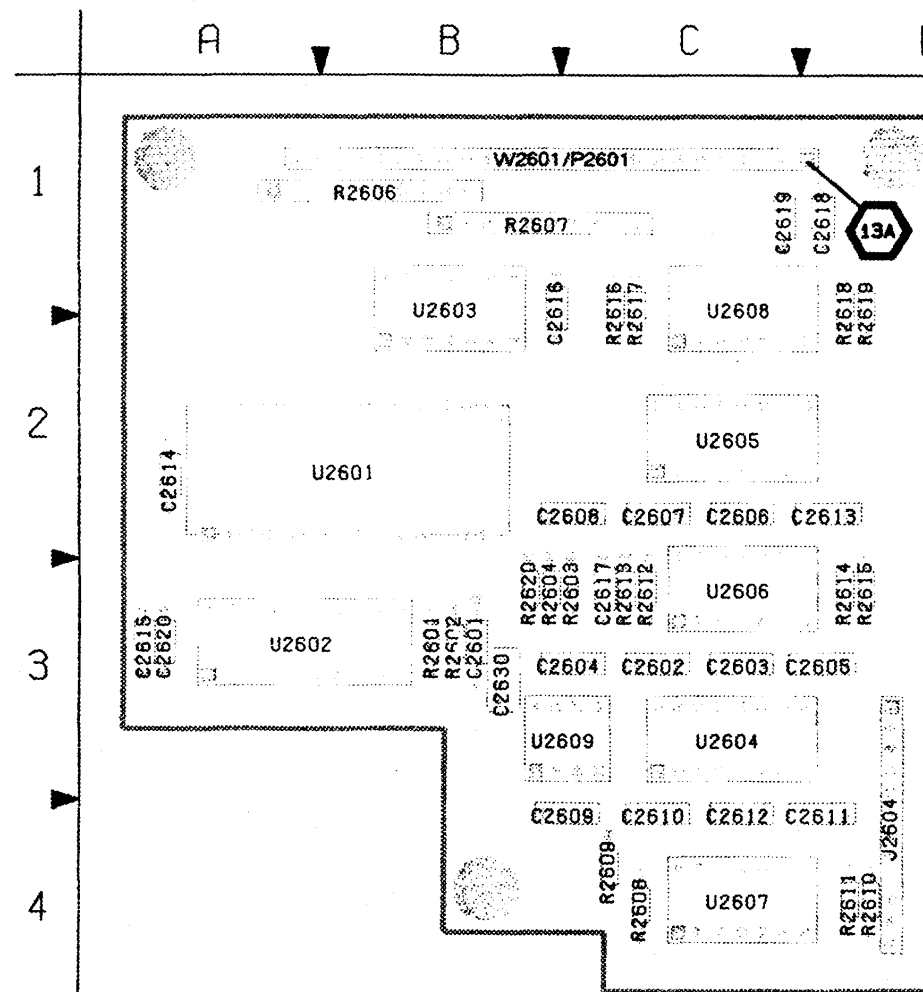
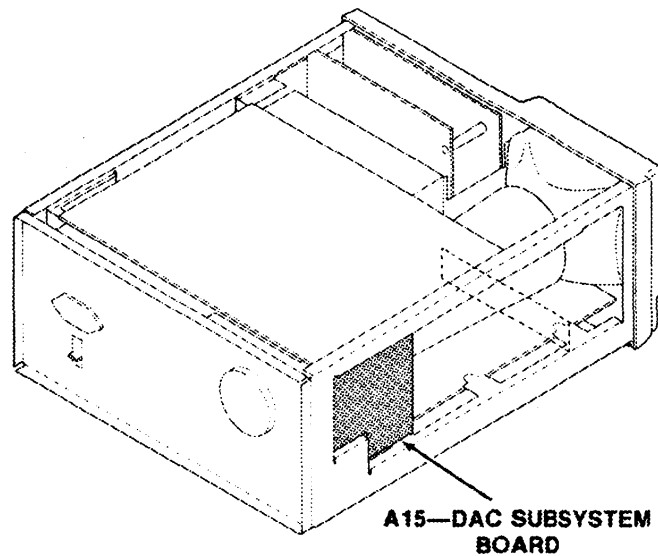

(6555-49)6367-27

Figure 9-11. A15—DAC Subsystem board.

A15—DAC SUBSYSTEM BOARD											
CIRCUIT NUMBER	SCHEM NUMBER	CIRCUIT NUMBER	SCHEM NUMBER	CIRCUIT NUMBER	SCHEM NUMBER	CIRCUIT NUMBER	SCHEM NUMBER	CIRCUIT NUMBER	SCHEM NUMBER	CIRCUIT NUMBER	SCHEM NUMBER
C2801	13	C2611	13	C2630	13	R2606	13	R2616	13	U2605	13
C2602	13	C2612	13			R2607	13	R2617	13	U2606	13
C2603	13	C2613	13	J2604	13	R2608	13	R2618	13	U2607	13
C2604	13	C2614	13			R2609	13	R2619	13	U2608	13
C2605	13	C2615	13	P2601	13	R2610	13	R2620	13	U2609	13
C2606	13	C2618	13			R2611	13				
C2607	13	C2617	13	R2601	13	R2612	13	U2601	13	W2601	13
C2608	13	C2618	13	R2602	13	R2613	13	U2602	13		
C2609	13	C2619	13	R2603	13	R2614	13	U2603	13		
C2610	13	C2620	13	R2604	13	R2615	13	U2604	13		

DAC SUBSYSTEM DIAGRAM 13

ASSEMBLY A15											
CIRCUIT NUMBER	SCHEM LOCATION	BOARD LOCATION	CIRCUIT NUMBER	SCHEM LOCATION	BOARD LOCATION	CIRCUIT NUMBER	SCHEM LOCATION	BOARD LOCATION	CIRCUIT NUMBER	SCHEM LOCATION	BOARD LOCATION
C2801	3G	3B	P2801	1B	1C	R2813	4L	3C	U2806A	4L	3C
C2802	4K	3C	P2801	7M	1C	R2814	5L	3D	U2806B	4L	3C
C2803	4K	3C				R2815	5L	3D	U2806C	4L	3C
C2804	5K	3C	R2801	2G	3B	R2816	5L	1C	U2806D	5L	3C
C2805	5K	3D	R2802	3G	3B	R2817	6L	1C	U2806	7D	3C
C2806	6K	2C	R2803	2H	3C	R2818	6L	1D	U2807A	2L	4C
C2807	6K	2C	R2804	6F	3B	R2819	7L	1D	U2807B	2L	4C
C2808	6K	2C	R2806	1C	1B	R2820	6B	3B	U2807C	3L	4C
C2809	2K	4C	R2807A	3C	1B				U2807D	3L	4C
C2810	2K	4C	R2807B	3C	1B	U2801	2E	2B	U2807	7D	4C
C2811	3K	4D	R2807C	3G	1B	U2801	5D	2B	U2808A	5L	1C
C2812	3K	4C	R2807D	3C	1B	U2802	1G	3A	U2808B	6L	1C
C2813	7K	2D	R2807E	3G	1B	U2802	7F	3A	U2808C	6L	1C
C2814	5C	2A	R2807F	3G	1B	U2803A	3D	1B	U2808D	7L	1C
C2815	5C	3A	R2807G	3G	1B	U2803B	4D	1B	U2808	7D	1C
C2816	5C	1B	R2807H	3G	1B	U2803C	4C	1B	U2809A	6C	3C
C2817	6F	3C	R2807I	3G	1B	U2803D	4C	1B	U2809B	2H	3C
C2818	6B	1D	R2808	2L	4C	U2803	5C	1B	U2809	7E	3C
C2819	7B	1C	R2809	2L	4C	U2804	1J	3C			
C2820	7B	3A	R2810	3L	4D	U2804	7F	3C	W2801	8B	1B
C2830	6B	3B	R2811	3L	4D	U2805	6J	2C	W2801	8M	1B
			R2812	4L	3C	U2805	7F	2C			
J2804	2M	4D									

A B C D E F G H J K L M N

← WAVEFORMS

1
2
3
4
5
6
7
8

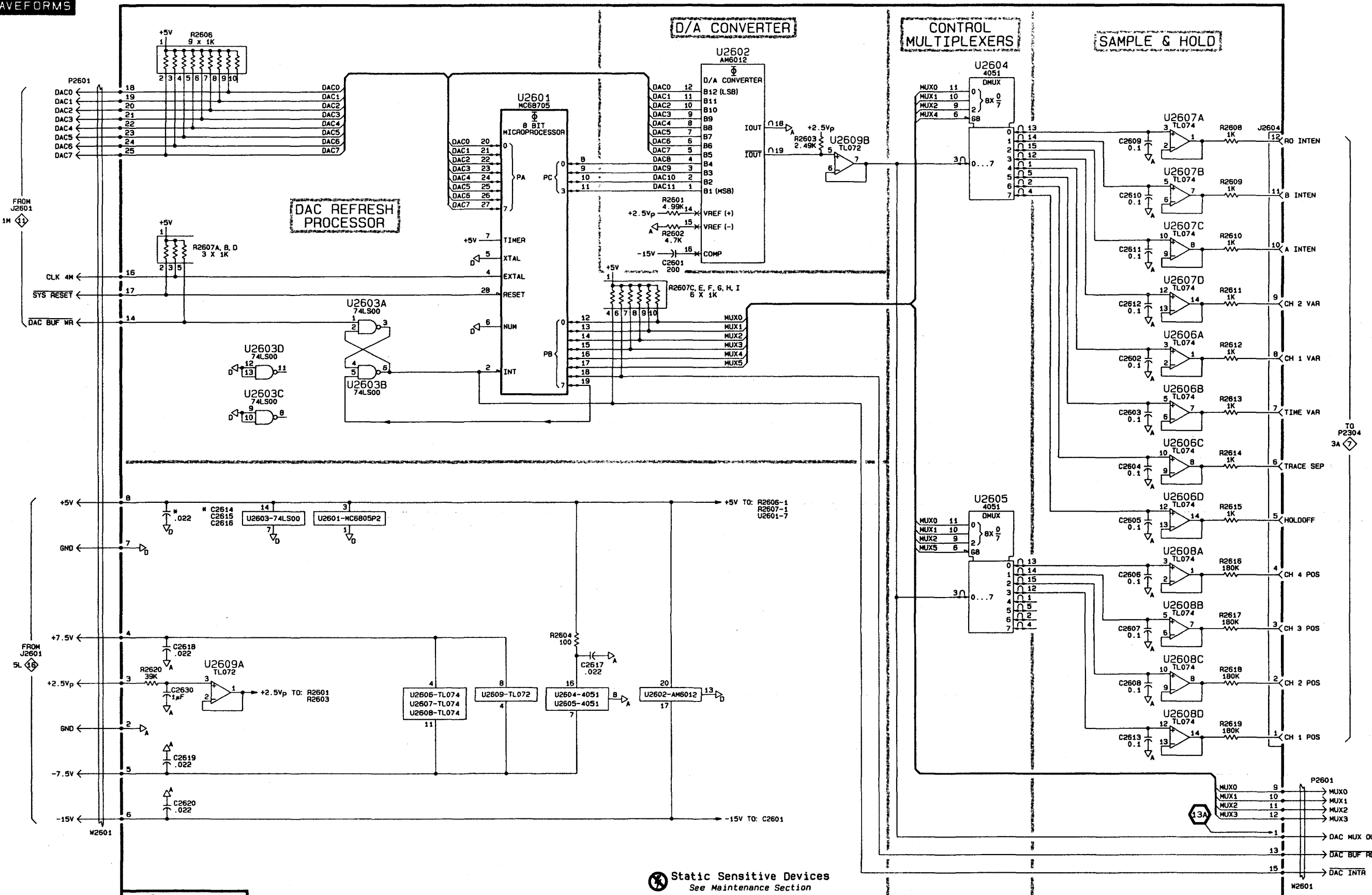

A15 DAC SUBSYSTEM BOARD

⚡ Static Sensitive Devices
See Maintenance Section

2247A

6367-13

DAC SUBSYSTEM

13

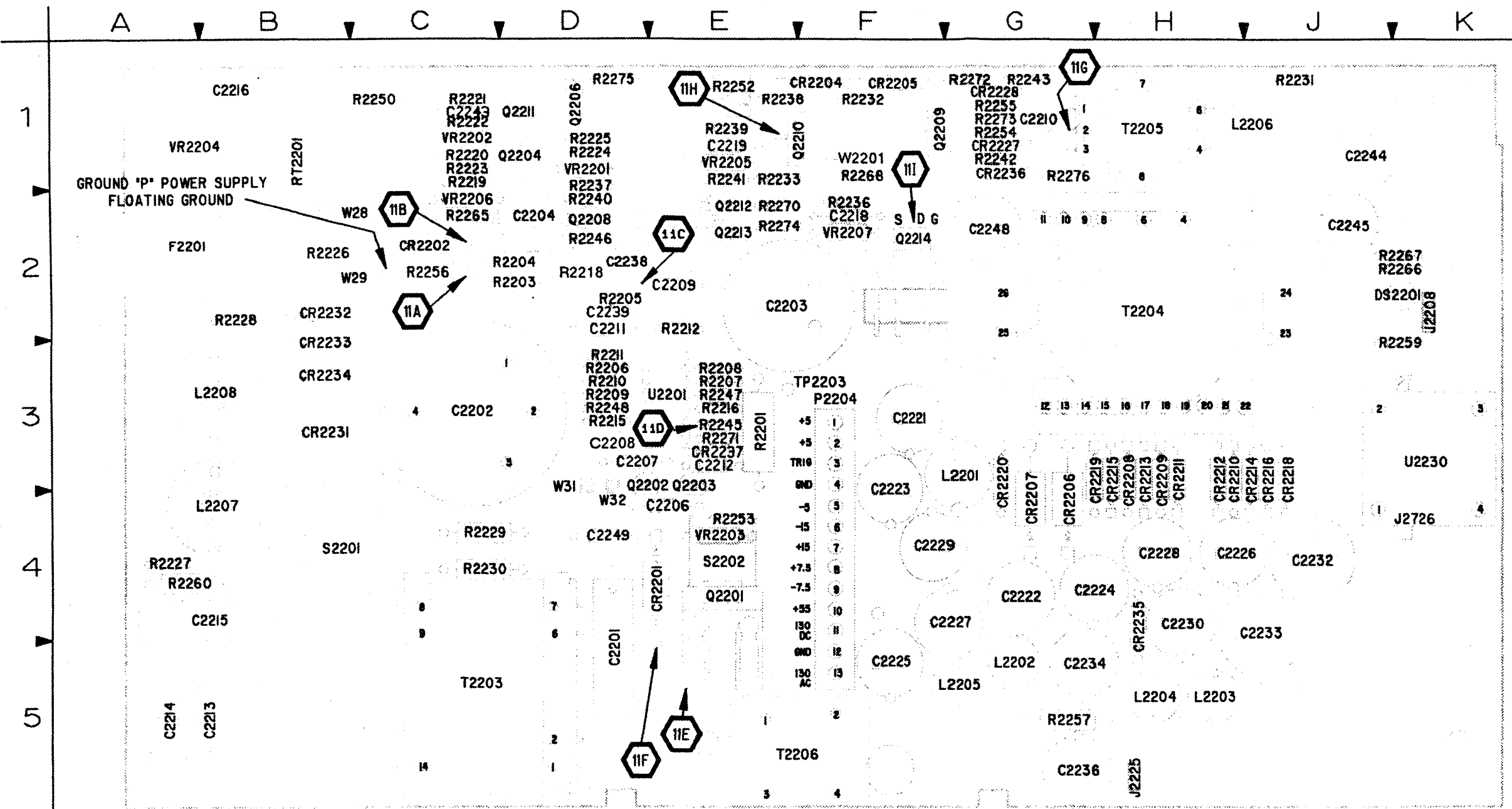

(6081-38)6555-36

Figure 9-12. A18—Power Supply board.

 Static Sensitive Devices
See Maintenance Section

COMPONENT NUMBER EXAMPLE

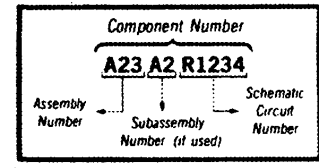

Chassis mounted components have no Assembly Number prefix—see end of Replaceable Electrical Parts List

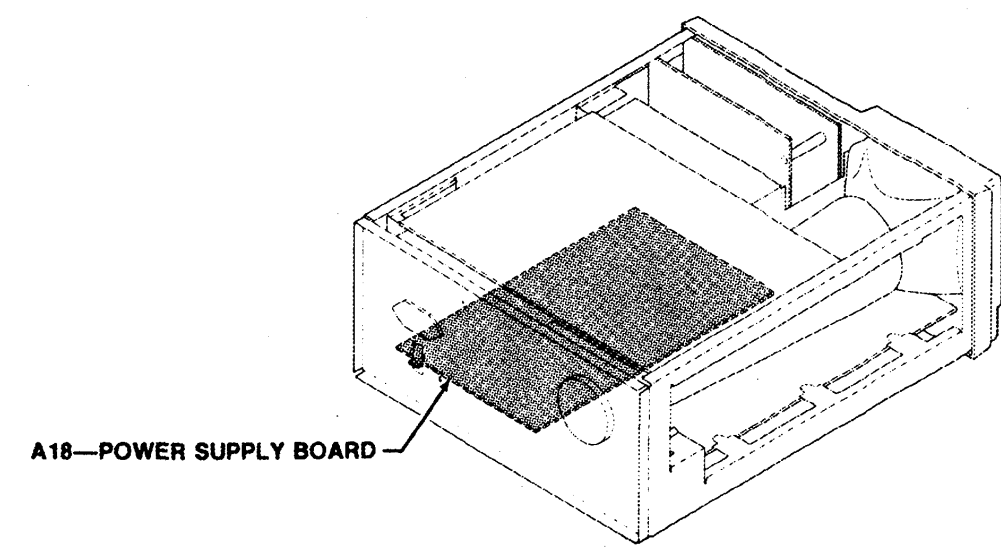

A18—POWER SUPPLY BOARD

A18—POWER SUPPLY BOARD

CIRCUIT NUMBER	SCHEM NUMBER	CIRCUIT NUMBER	SCHEM NUMBER	CIRCUIT NUMBER	SCHEM NUMBER	CIRCUIT NUMBER	SCHEM NUMBER	CIRCUIT NUMBER	SCHEM NUMBER	CIRCUIT NUMBER	SCHEM NUMBER
C2201	14	C2238	14	CR2235	14	Q2212	14	R2233	14	R2276	14
C2202	14	C2239	14	CR2236	14	Q2213	14	R2236	14		
C2203	14	C2243	14	CR2237	14	Q2214	14	R2237	14	RT2201	14
C2204	14	C2244	14					R2238	14		
C2206	14	C2245	14	DS2201	14	R2201	14	R2239	14	S2201	14
C2207	14	C2248	14			R2203	14	R2240	14		
C2208	14	C2249	14	F2201	14	R2204	14	R2241	14	T2203	14
C2209	14					R2205	14	R2242	14	T2204	14
C2210	14	CR2201	14	J2208	14	R2206	14	R2243	14	T2205	14
C2211	14	CR2202	14	J2225	14	R2207	14	R2245	14	T2206	14
C2212	14	CR2204	14	J2726	14	R2208	14	R2246	14		
C2213	14	CR2205	14			R2209	14	R2247	14	U2201	14
C2214	14	CR2206	14	L2201	14	R2210	14	R2248	14	U2230	14
C2215	14	CR2207	14	L2202	14	R2211	14	R2250	14		
C2216	14	CR2208	14	L2203	14	R2212	14	R2252	14	VR2201	14
C2217	14	CR2209	14	L2204	14	R2215	14	R2253	14	VR2202	14
C2218	14	CR2210	14	L2205	14	R2216	14	R2254	14	VR2203	14
C2219	14	CR2211	14	L2206	14	R2218	14	R2255	14	VR2204	14
C2221	14	CR2212	14	L2207	14	R2219	14	R2256	14	VR2205	14
C2222	14	CR2213	14	L2208	14	R2220	14	R2257	14	VR2206	14
C2223	14	CR2214	14			R2221	14	R2259	14	VR2207	14
C2224	14	CR2215	14	P2204	14	R2222	14	R2260	14		
C2225	14	CR2216	14			R2223	14	R2265	14	W28	14
C2226	14	CR2218	14	Q2201	14	R2224	14	R2266	14	W29	14
C2227	14	CR2219	14	Q2202	14	R2225	14	R2267	14	W31	14
C2228	14	CR2220	14	Q2203	14	R2226	14	R2268	14	W32	14
C2229	14	CR2227	14	Q2204	14	R2227	14	R2270	14	W2201	14
C2230	14	CR2228	14	Q2206	14	R2228	14	R2271	14		
C2232	14	CR2231	14	Q2208	14	R2229	14	R2272	14		
C2233	14	CR2232	14	Q2209	14	R2230	14	R2273	14		
C2234	14	CR2233	14	Q2210	14	R2231	14	R2274	14		
C2236	14	CR2234	14	Q2211	14	R2232	14	R2275	14		

WAVEFORMS FOR DIAGRAM 14

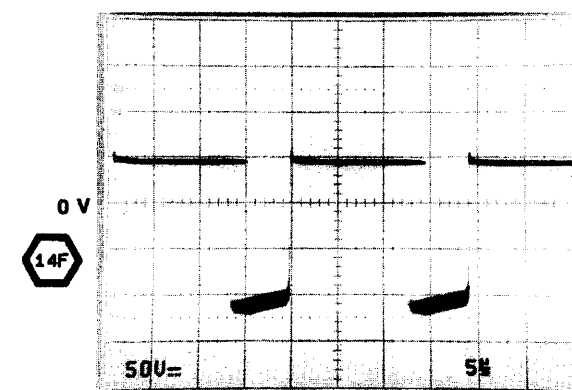
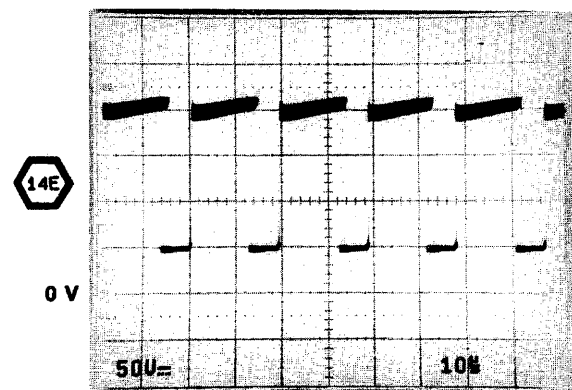
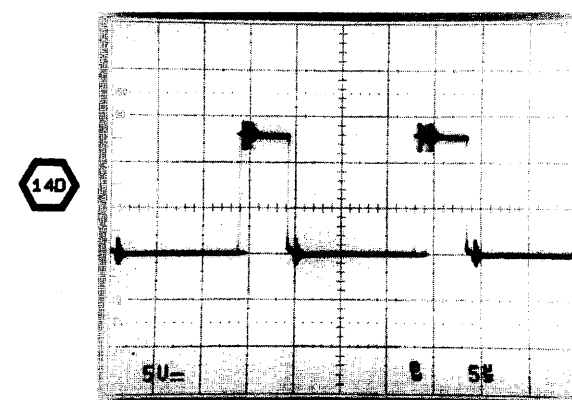
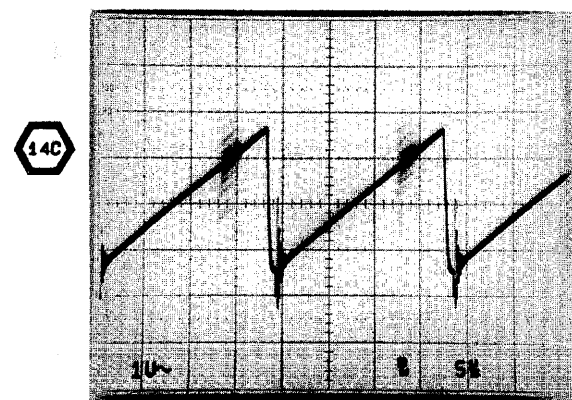
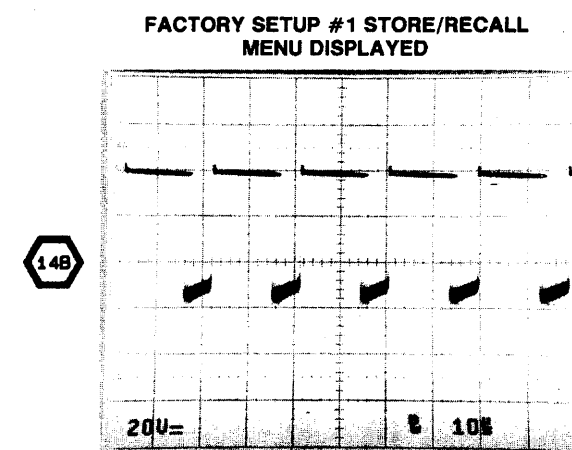
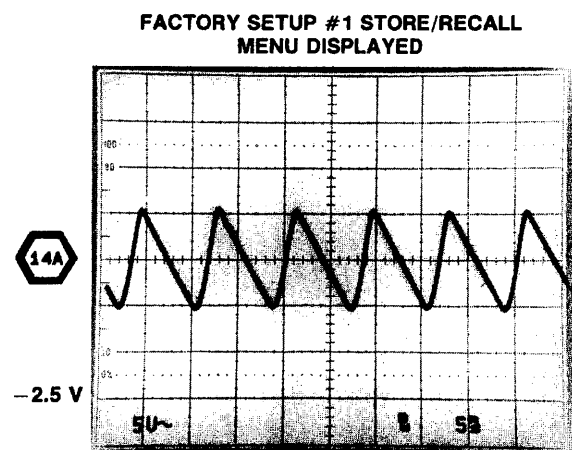

WAVEFORMS FOR DIAGRAM 14 (cont)

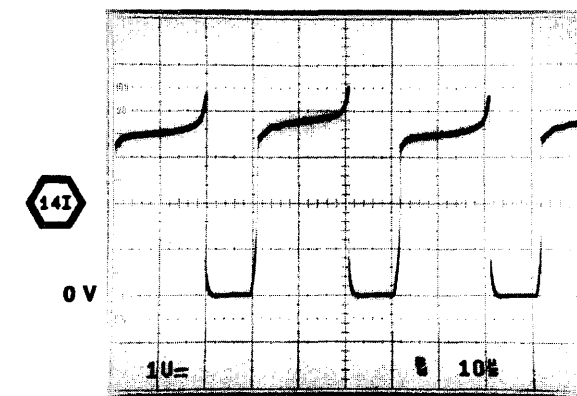
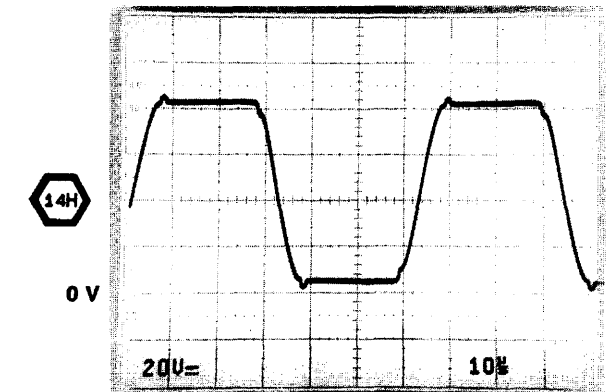
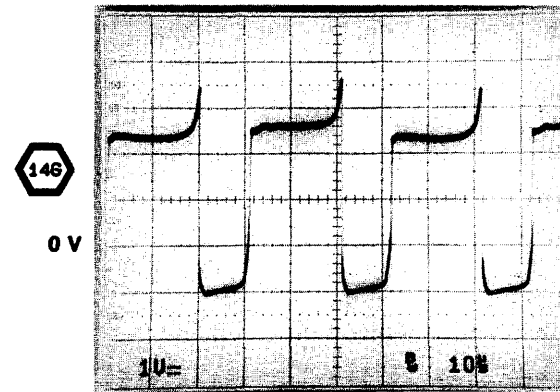

POWER SUPPLY DIAGRAM 14

ASSEMBLY A18											
CIRCUIT NUMBER	SCHEM LOCATION	BOARD LOCATION	CIRCUIT NUMBER	SCHEM LOCATION	BOARD LOCATION	CIRCUIT NUMBER	SCHEM LOCATION	BOARD LOCATION	CIRCUIT NUMBER	SCHEM LOCATION	BOARD LOCATION
C2201	3H	5D	CR2208	5L	3H	Q2210	7K	1E	R2250	1A	1C
C2202	2D	3D	CR2210	5L	3H	Q2211	2E	1D	R2252	6H	1E
C2203	5H	2E	CR2211	5L	3H	Q2212	6G	2E	R2253	4G	4E
C2204	3D	2D	CR2212	4L	3H	Q2213	6H	2E	R2254	7J	1G
C2206	4G	4E	CR2213	4L	3H	Q2214	8J	2F	R2255	6K	1G
C2207	3E	3D	CR2214	4L	3J				R2256	2D	2C
C2208	3E	3D	CR2215	4M	3H	R2201	5H	3E	R2257	8M	5G
C2209	4E	2E	CR2216	4M	3J	R2203	2D	2D	R2259	8M	3K
C2210	6K	1G	CR2218	3M	3J	R2204	2D	2D	R2260	1B	4A
C2211	4E	2D	CR2219	3L	3H	R2205	6E	2D	R2265	2D	2C
C2212	4G	3E	CR2220	3L	3G	R2206	4D	3D	R2266	8M	2K
C2213	2B	5B	CR2227	7J	1G	R2207	5D	3E	R2267	8M	2K
C2214	1B	5A	CR2228	7K	1G	R2208	5E	3E	R2268	6J	1F
C2215	2B	4B	CR2231	2C	3B	R2209	5E	3D	R2270	8G	2E
C2216	2B	1B	CR2232	1C	2B	R2210	4E	3D	R2271	4F	3E
C2217	2C	3B	CR2233	1C	3B	R2211	4E	3D	R2272	7K	1G
C2218	8H	2F	CR2234	2C	3B	R2212	4D	2E	R2273	6J	1G
C2219	6J	1E	CR2235	4L	4H	R2215	4E	3D	R2274	6G	2E
C2221	2M	3F	CR2236	6J	1G	R2216	4F	3E	R2275	5E	1D
C2222	2M	4G	CR2237	4G	3E	R2218	3E	2D	R2276	6J	1G
C2223	3M	3F				R2219	3D	1C			
C2224	3M	4G	DS2201	8M	2K	R2220	3E	1C	RT2201	1A	1B
C2225	5M	5F				R2221	2E	1C			
C2226	5M	4H	F2201	2A	2A	R2222	2E	1C	S2201	1C	4B
C2227	5M	4G				R2223	3D	1C			
C2228	5M	4H	J2208	7M	2K	R2224	6F	1D	T2203	2H	5C
C2229	4M	4F	J2225	6M	5H	R2225	6F	1D	T2204	2K	2H
C2230	4M	4H	J2726	6M	4K	R2226	2A	2B	T2205	6K	1H
C2232	3M	4J				R2227	1B	4A	T2206	1C	5E
C2233	4M	4J	L2201	2M	3G	R2228	2B	2B			
C2234	5L	5G	L2202	3M	5G	R2229	1C	4C	U2201	5F	3E
C2236	6M	5G	L2203	5M	5H	R2230	1C	4C	U2230	7L	3K
C2238	6E	2D	L2204	4M	5H	R2231	7M	1J			
C2239	4E	2D	L2205	4M	5G	R2232	6J	1F	VR2201	5F	1D
C2243	2E	1C	L2206	6K	1J	R2233	6G	1E	VR2202	3E	1C
C2244	7M	1J	L2207	1B	4B	R2236	6G	2F	VR2203	4H	4E
C2245	7L	2J	L2208	2B	3B	R2237	6E	1D	VR2204	2A	1A
C2248	6J	2G				R2238	6H	1E	VR2205	5G	1E
C2249	4G	4D	P2204	1M	4F	R2239	5H	1E	VR2206	3D	2C
						R2240	6E	2D	VR2207	8J	2F
CR2201	4H	4E	Q2201	4H	4E	R2241	5H	1E			
CR2202	2G	2C	Q2202	3G	3D	R2242	7J	1G	W28	2A	2C
CR2204	6J	1F	Q2203	4G	3E	R2243	7K	1G	W29	1A	2C
CR2205	6J	1F	Q2204	3E	1D	R2245	4F	3E	W31	3E	3D
CR2206	2L	4G	Q2206	6F	1D	R2246	6E	2D	W32	3F	4D
CR2207	2L	4G	Q2208	6E	2D	R2247	5D	3E	W2201	7J	1F
CR2208	6L	3H	Q2209	7J	1F	R2248	3E	3D			
OTHER PARTS											
B25	6N	CHASSIS	FL2201	2A	CHASSIS	P25	6N	CHASSIS	S2202	3E	CHASSIS

A B C D E F G H J K L M N

1
2
3
4
5
6
7
8

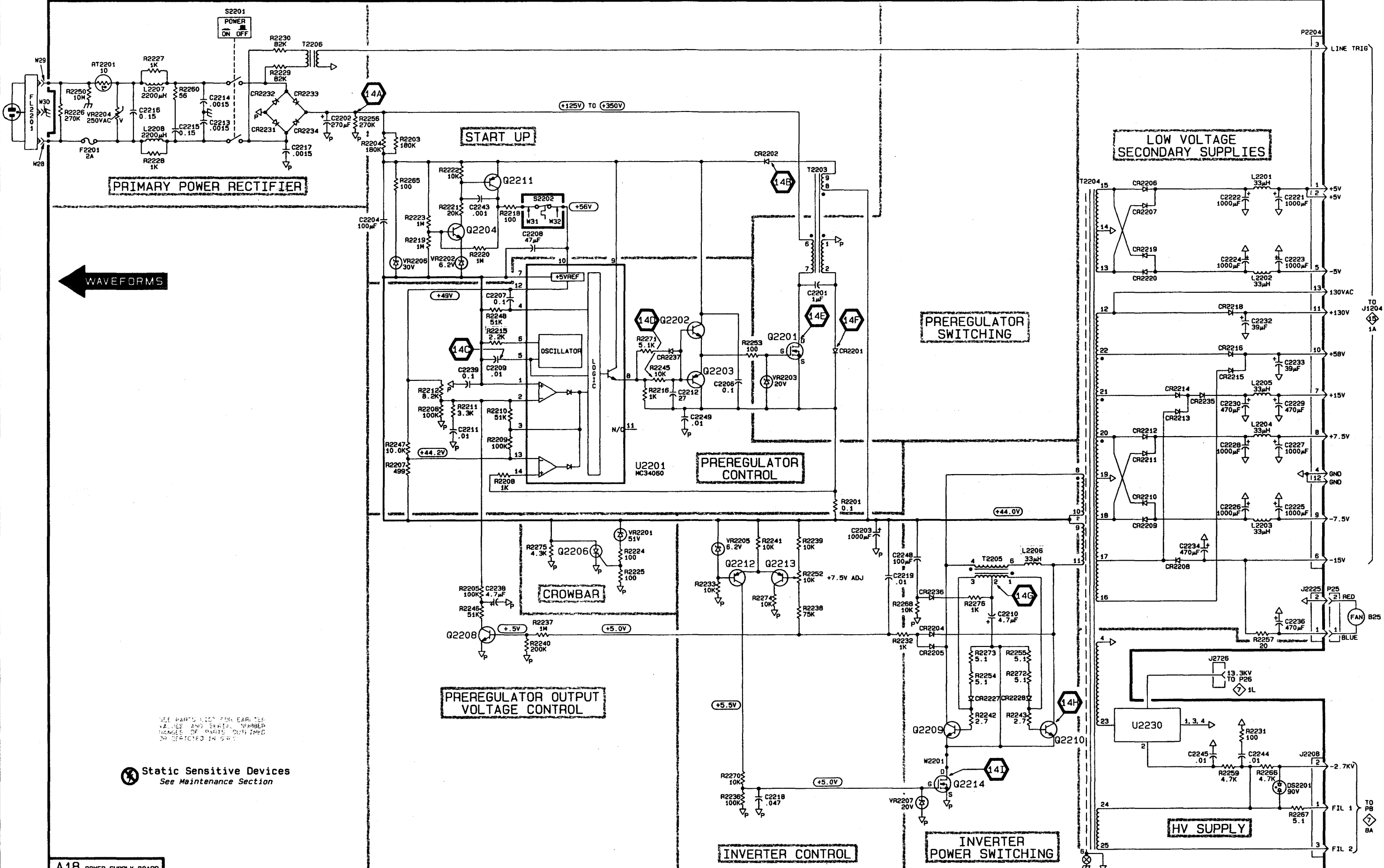

← WAVEFORMS

SEE PART LIST FOR EARLIER
VALUES AND SERIAL NUMBER
RANGES OF PARTS OBTAINED
OR SPECIFIED IN GRY.

⊗ Static Sensitive Devices
See Maintenance Section

A18 POWER SUPPLY BOARD

2247A

5367-14
REV MAR 1990

POWER SUPPLY

14

MAIN BOARD POWER DISTRIBUTION DIAGRAM 15

ASSEMBLY A8											
CIRCUIT NUMBER	SCHEM LOCATION	BOARD LOCATION	CIRCUIT NUMBER	SCHEM LOCATION	BOARD LOCATION	CIRCUIT NUMBER	SCHEM LOCATION	BOARD LOCATION	CIRCUIT NUMBER	SCHEM LOCATION	BOARD LOCATION
W900	5M	1E									
<i>Partial A8 also shown on diagram 7.</i>											
ASSEMBLY A10											
C135	7D	2B	C610	2H	2L	R374	5D	10E	U600	2G	2M
C136	8E	2B	C613	1H	1N	R390	1L	8F	U601	2H	1N
C140	8D	2C	C701	3J	10J	R392	8F	7C	U602	1E	3K
C155	7E	2B	C702	3K	9J	R480	2B	4F	U603	2G	2K
C156	8E	1B	C703	3K	10K	R481	2D	1J	U604	2H	2L
C171	5A	2B	C704	3L	9K	R504	1M	9C	U606	3F	3M
C172	1A	3C	C705	4A	9G	R701	3J	8J	U701	3K	10J
C180	8D	3D	C708	3J	9J	R709	2K	9J	U702	3K	9K
C181	7A	6D	C801	4A	8K	R723	5H	8J	U801	5H	7H
C205	3J	10H	C806	5H	8H	R733	3K	10K	U802	6H	8H
C206	3J	10H	C815	6H	7H	R734	4B	9H	U901A	5K	9A
C214	7B	4E	C816	7H	8H	R837	7H	9K	U901B	5L	9A
C215	7B	5D	C818	4B	8J	R915	5L	9A	U901	5J	9A
C216	2B	5G	C821	5H	7J	R916	5L	9A	U930	5J	8B
C217	1B	5G	C822	6E	8J	R1026	8F	7M	U931	3M	9B
C219	7B	5D	C901	5K	9B	R1027	6F	8L	U932	5K	8A
C224	7B	3D	C902	5K	8A	R1101*	8H	3J	U1001	7F	7L
C225	7B	3D	C903	5M	8A	R1102*	8G	4J	U1101	7H	4G
C229	7B	4D	C904	5M	9B	R1108*	7J	4G	U1102	7H	4G
C234	7C	2D	C1005	7F	7M	R1158	1F	4L	U1103	2F	5K
C235	7C	2D	C1006	6G	8L	R1159	2G	5J	U1104	2C	4H
C239	7C	2D	C1101	8H	3H	R1160	6K	5J	U1106	2G	5L
C244	7D	1D	C1102	8G	4G	R2783	4D	7N			
C245	7C	1D	C1104	2C	4H				W235	7E	5E
C249	7D	2D	C1108*	7J	4G	U112	7D	6C	W501	1H	1M
C265	5B	5F	C1158	1F	5L	U122	7D	4C	W606	1E	1K
C282	3B	4F	C1159	2G	5L	U171	5A	3B	W607	2E	5M
C283	6B	6G	C1160	6K	5K	U172	6A	3B	W900	5M	9B
C297	3C	5F	C2701	8H	7M	U173	1A	3C	W1104*	6J	4J
C298	3B	3F	C2702	8G	6L	U201	1B	5H	W1105*	8H	4J
C304	5D	7D	C2709	4E	7M	U202	1B	5G	W1200	1J	6F
C309	2J	7H				U203	3J	10G	W1201	3M	9C
C316	5C	8E	J1204	1A	5J	U210	7B	5E	W1202	2J	9H
C317	1L	8E				U220	7B	4E	W1203	1G	1J
C318	8J	9E	L101	5A	2C	U230	7C	3E	W1204	1J	7G
C320	1J	8G	L102	8D	2C	U240	7C	2E	W1205	2G	2J
C322	2M	9D	L201	6A	6E	U260	5B	5F	W1209	1E	4J
C337	5D	9E	L216	2B	4H	U301	1L	9D	W1210	3G	2J
C338	8A	8G	L217	1B	5H	U302	5E	8C	W1216	3M	8C
C339	8B	9G	L445	1B	3J	U303	5E	9C	W1217	3G	6H
C351	5F	8C	L475	1D	1J	U304	5F	8D	W1218	3G	5H
C442	3G	2H				U307	5E	7D	W1221	3E	1J
C445	1B	3F	P2302	8M	10D	U308	5E	7D	W1222	8B	6D
C475	1D	1F	P2502	1N	1L	U309	5F	7C	W1223	3L	6D
C480	2D	1J				U310	5E	10D	W1231	6F	8K
C481	2C	3F	R182	8D	6D	U311	5E	10D	W1237	8F	6L
C482	2D	2F	R208	3J	10H	U315	1J	8F	W1247	5C	6D
C501	3E	4M	R226	7B	6E	U316	2J	7H	W1248	5H	6H
C502	3E	4N	R245	7C	3D	U421	2B	3F	W1249	5H	5H
C503	3E	4N	R282	3B	3F	U431	2D	2F	W1250	5H	8K
C505	2M	9C	R283	6B	6G	U441	1D	1H	W1251	8A	6H
C604	3F	3M	R297	3C	6F	U442	3G	2H	W1252	8A	5H
C605	1H	2M	R298	3B	3F	U501	3E	5M	W1255	5B	6F
C606	1E	3L	R312	5D	7D	U502	3E	4N	W1277	4D	8K
C609	2H	2J	R339	8J	9E	U503	3E	5N	W2302	8M	10D
			R345	5C	8E	U506	2M	10C	W2502	1M	1L

Partial A10 also shown on diagrams 1, 2, 3, 4, 5, 6 and 7.

***See Parts List for serial number ranges.**

PROCESSOR BOARD POWER DISTRIBUTION DIAGRAM 16

ASSEMBLY A12											
CIRCUIT NUMBER	SCHEM LOCATION	BOARD LOCATION	CIRCUIT NUMBER	SCHEM LOCATION	BOARD LOCATION	CIRCUIT NUMBER	SCHEM LOCATION	BOARD LOCATION	CIRCUIT NUMBER	SCHEM LOCATION	BOARD LOCATION
J2105	3L	1B									
<i>Partial A14 also shown on diagram 10.</i>											
ASSEMBLY A14											
C2001	1M	2B	P2501	1L	1B	U2001 U2002	1L 1L	2B 4B	W2501	1L	1B
<i>Partial A14 also shown on diagram 10.</i>											
ASSEMBLY A16											
C1908	7D	2G	C2502	2C	4G	U2300	1E	5B	U2412	6G	5D
C1915	7D	1J	C2503	2C	4F	U2301	1E	5B	U2413	7G	5C
C2304	3B	8A	C2504	2C	5G	U2302	1H	6B	U2414	6H	8D
C2311	1C	5B	C2505	2C	5K	U2303	6G	6A	U2415	7H	6C
C2312	1C	5B	C2506	2C	5H	U2304	6C	7B	U2416	7C	7C
C2313	1C	6B	C2507	2C	4G	U2305	7C	7B	U2417	1F	1A
C2314	6B	8A	C2508	2C	4G	U2306	6E	7C	U2501	1C	6G
C2315	7B	7C	C2509	2C	6F	U2308	6F	7G	U2502	1G	6K
C2316	1J	7C	C2510	2C	6J	U2309	7F	6G	U2503	1F	4H
C2317	6G	7C	C2511	2C	4H	U2313	1E	6E	U2506	2F	5K
C2319	1C	5F	C2530	2C	6H	U2314	6C	6B	U2512	2E	4F
C2321	1C	6F	C2531	2C	6H	U2400	1G	3C	U2513	2E	4J
C2401	1C	3B	C2532	2C	7H	U2401	2E	5E	U2514	2E	5H
C2402	1C	4B	C2541	1B	6K	U2402	2E	5E	U2515	2E	4H
C2403	1C	1D				U2403	2E	1C	U2517	1F	5F
C2404	1C	5E	J2302	3B	8B	U2404	1F	4B	U2518	1F	4K
C2405	1C	2A	J2501	1L	8J	U2405	1F	3B	U2519	1D	6J
C2406	1C	4A	J2502	1B	2K	U2406	1D	4C	U2523	2E	7H
C2407	2C	4D	J2601	5L	2A	U2407	1F	5E	U2524	2E	6J
C2408	2C	5D				U2408	1D	5C	U2525	2E	7J
C2409	2C	3D	P2105	3L	8G	U2409	1F	2B			
C2410	2C	2B				U2410	2E	2B	W2105	4L	8G
C2415	6H	7D	R2309	6G	7C	U2411	2E	4B			
C2501	2C	4K	R2412	6H	7D						
<i>Partial A16 also shown on diagrams 8, 9, 10, 11 and 12.</i>											

A B C D E F G H J K L M N

1
2
3
4
5
6
7
8

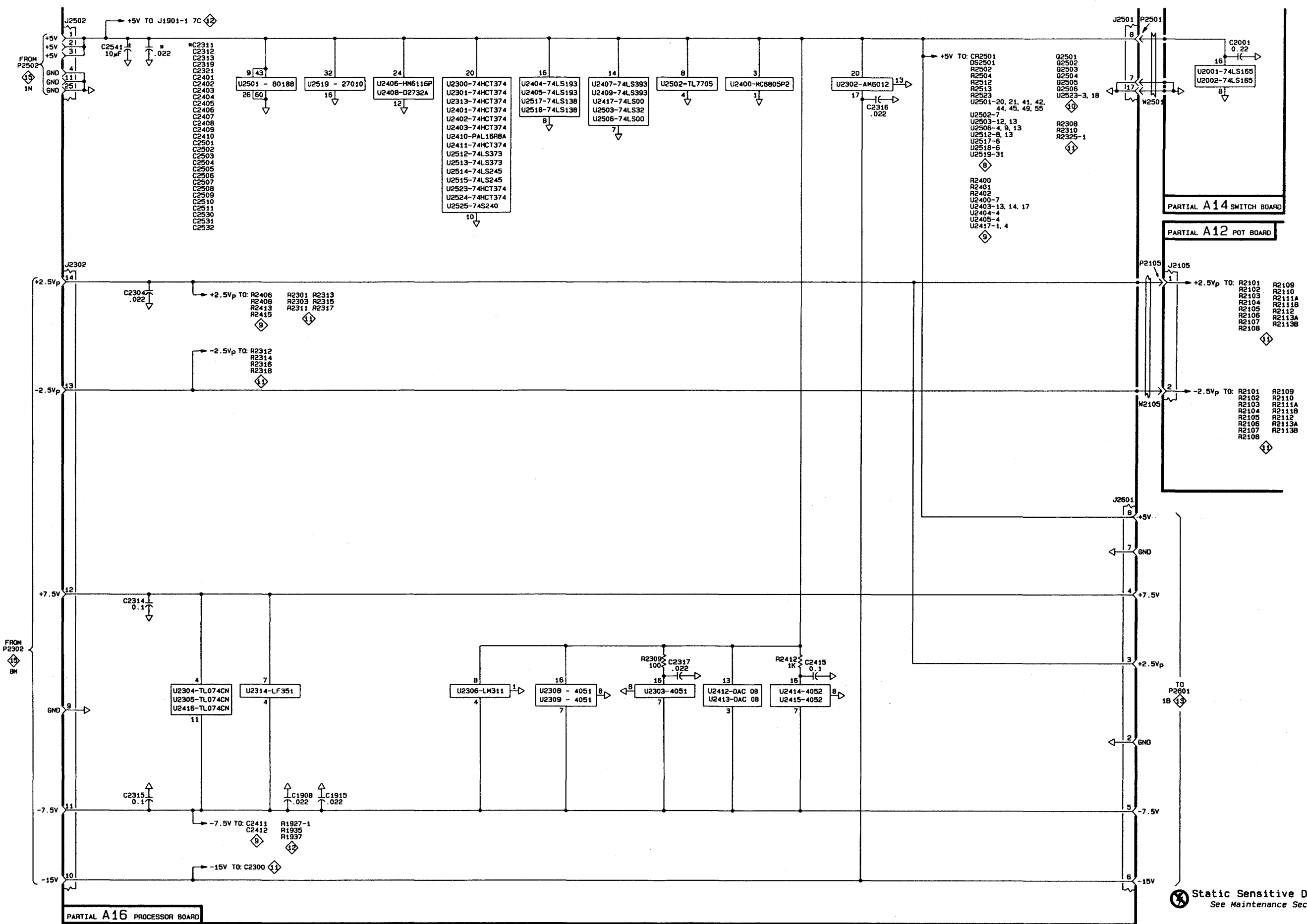

Static Sensitive Devices
See Maintenance Section

2247A

6367-16

PROCESSOR BOARD POWER DISTRIBUTION

16

A25 - CH 2 SIGNAL OUT BOARD
FIG. 9-12A

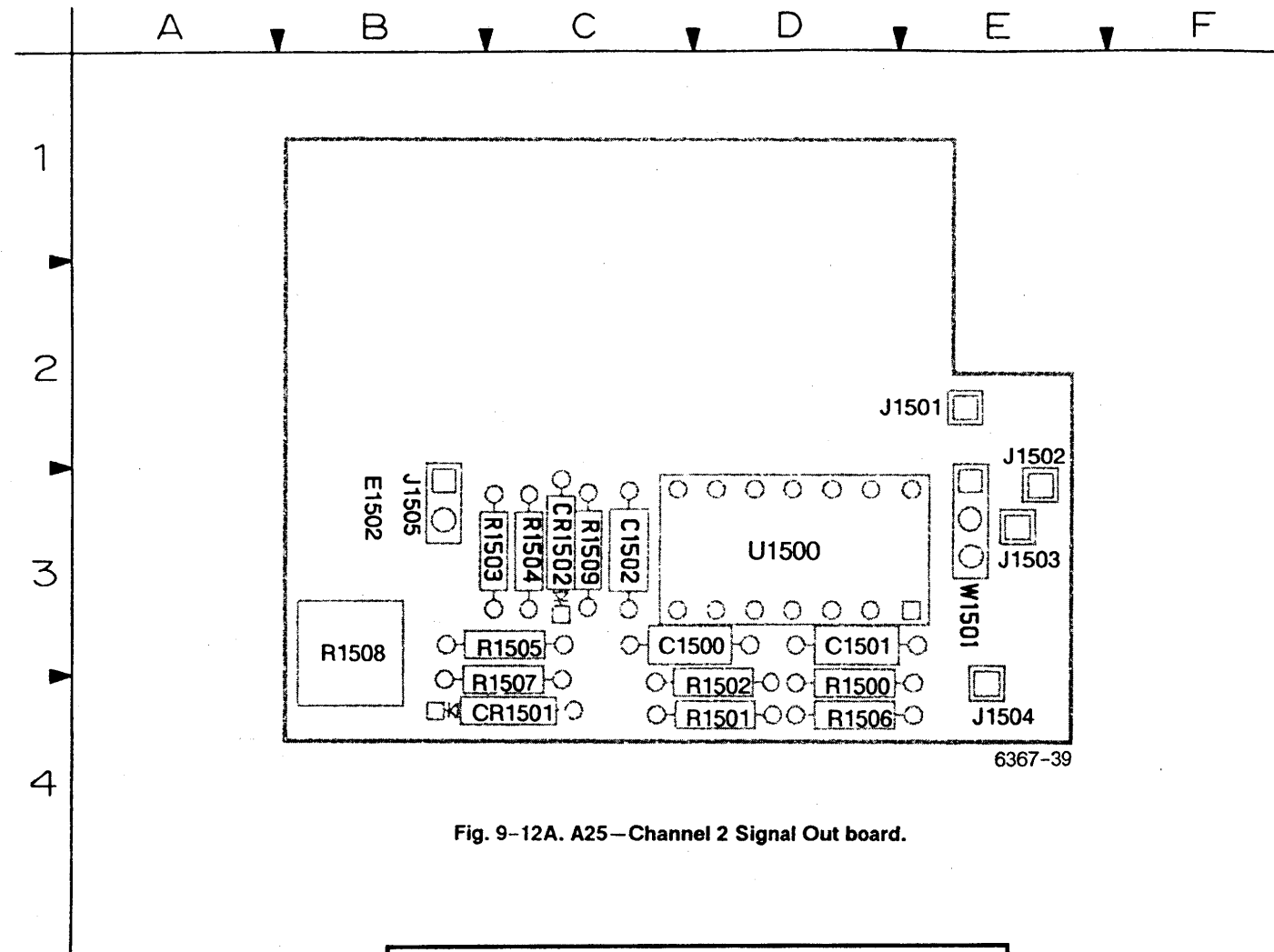
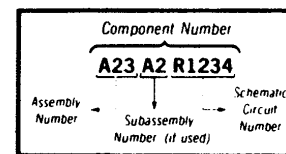

Fig. 9-12A. A25—Channel 2 Signal Out board.

A25—CH 2 SIGNAL OUT BOARD (OPTION 15)					
CIRCUIT NUMBER	SCHEM NUMBER	CIRCUIT NUMBER	SCHEM NUMBER	CIRCUIT NUMBER	SCHEM NUMBER
C1500	18	J1503	18	R1505	18
C1501	18	J1504	18	R1506	18
C1502	18	J1505	18	R1507	18
				R1508	18
CR1500	18	R1500	18	R1509	18
CR1501	18	R1501	18	U1500	18
		R1502	18		
J1501	18	R1503	18		
J1502	18	R1504	18		

 Static Sensitive Devices
See Maintenance Section

COMPONENT NUMBER EXAMPLE



Chassis mounted components have no Assembly Number prefix—see end of Replaceable Electrical Parts List

CH 2 SIGNAL OUT BOARD (OPTION 15) DIAGRAM 18

ASSEMBLY A25											
CIRCUIT NUMBER	SCHEM LOCATION	BOARD LOCATION	CIRCUIT NUMBER	SCHEM LOCATION	BOARD LOCATION	CIRCUIT NUMBER	SCHEM LOCATION	BOARD LOCATION	CIRCUIT NUMBER	SCHEM LOCATION	BOARD LOCATION
C1500	3B	3D	J1502	3E	2E	R1502	3B	4D	R1509	2C	3C
C1501	3D	3D	J1503	3E	3E	R1503	1B	3C	U1500A	2A	3D
C1502	3D	3C	J1504	4E	3E	R1504	2B	3C	U1500B	2B	3D
CR1500	2D	3C	J1505	2E	3B	R1505	2D	3C	U1500C	2B	3D
CR1501	2C	4C	R1500	3B	4D	R1506	3A	4D	U1500D	1D	3D
J1501	2E	2E	R1501	3B	4D	R1507	2A	4C	U1500E	1C	3D
						R1508	1B	3B			
CHASSIS MOUNTED PARTS											
E1502*	2E	CHASSIS	J1506	2F	CHASSIS	W1502	2E	CHASSIS			

*See Parts List for serial number ranges.

A B C D E F

1
2
3
4

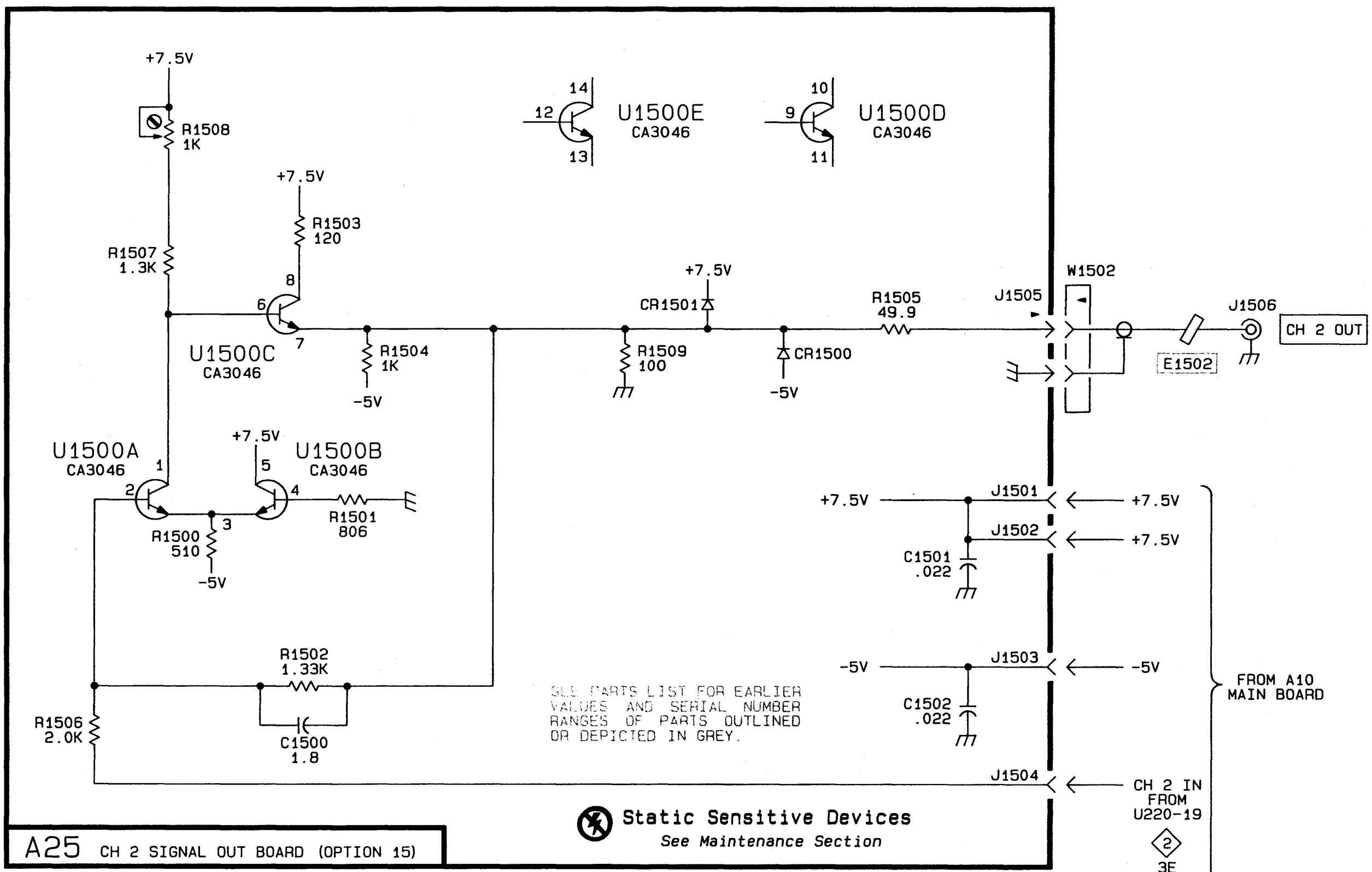

A25 CH 2 SIGNAL OUT BOARD (OPTION 15)

2247A

6367-40
ADD MAR 1990

CH 2 SIGNAL OUT OPTION 18

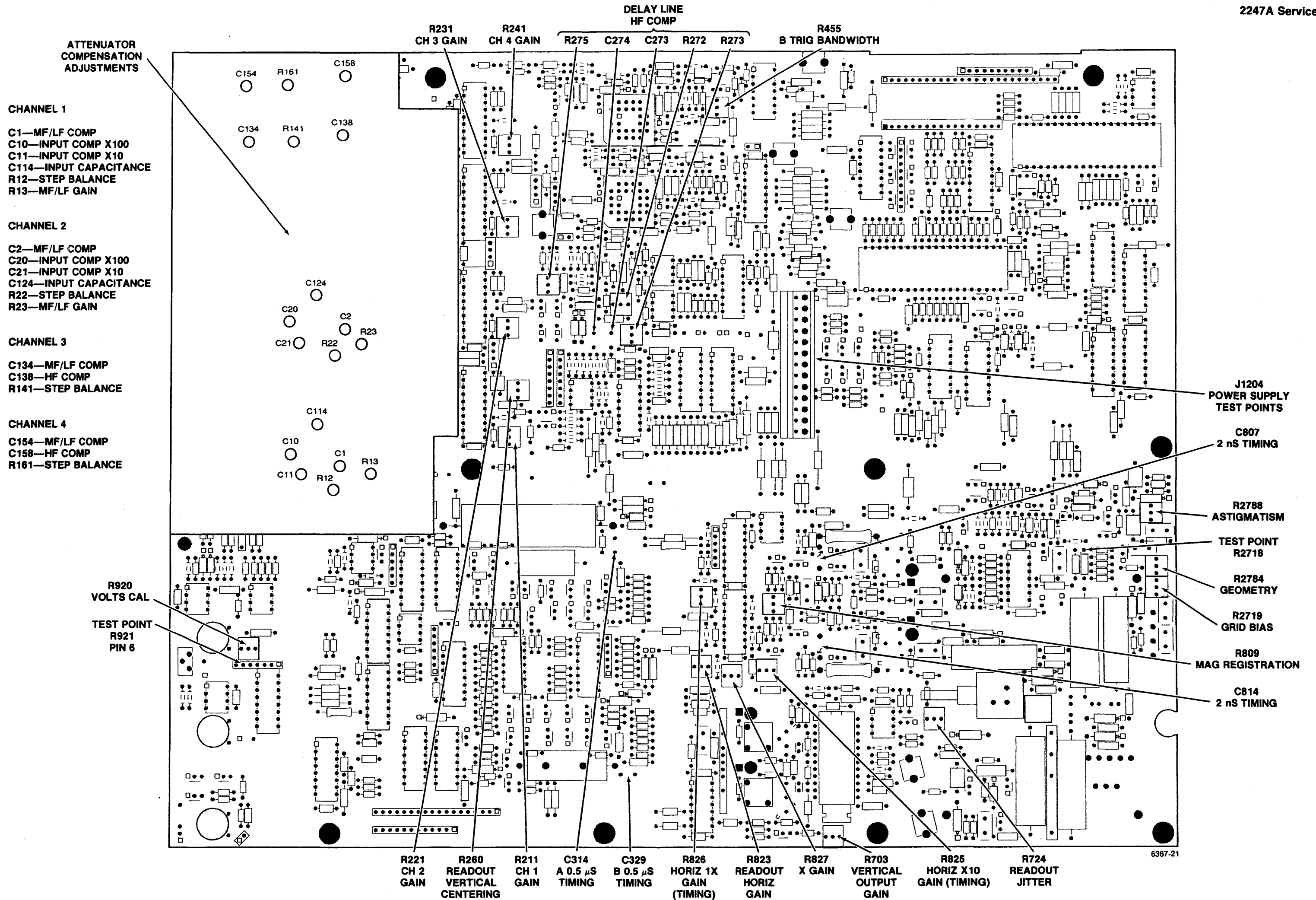

Figure 9-13. Main board adjustment locations.

REPLACEABLE MECHANICAL PARTS

Replacement parts are available from or through your local Tektronix, Inc. Field Office or representative.

When ordering parts, include the following information in your order: part number, instrument type or number, serial number, and modification number if applicable.

If a part you have ordered has been replaced with a new or improved part, your local Tektronix, Inc. Field Office or representative will contact you concerning any change in part number.

Change information, if any, is located at the rear of this manual.

ITEM NAME

In the parts list, an item name is separated from the description by a colon(:). Because of space limitations, an item name may sometimes appear as incomplete. For further item name identification, the U.S. Federal Cataloging Handbook H6-1 can be utilized where possible.

FIGURE AND INDEX NUMBERS

Items in this section are referenced by figure and index numbers to the illustrations.

INDENTATION SYSTEM

This mechanical parts list is indented to indicate item relationships. Following is an example of the indentations system used in the description column.

1 2 3 4 5 *Name & Description*

Assembly and/or component

Attaching parts for assembly and/or component

END ATTACHING PARTS

Detail part of assembly and/or component

Attaching parts for detail part

END ATTACHING PARTS

Parts of detail part

Attaching parts for parts or detail part

END ATTACHING PARTS

Attaching parts always appear in the same indentation as the item it mounts, while the detail parts are indented to the right. Indented items are part of, and included with, the next higher indentation.

Attaching parts must be purchased separately, unless otherwise specified.

ABBREVIATIONS

Abbreviations conform to American National Standard Y1.1.

CROSS INDEX - MFR. CODE NUMBER TO MANUFACTURER

Mfr. Code	Manufacturer	Address	City, State, Zip Code
06915	RICHCO PLASTIC CO	5825 N TRIPP AVE	CHICAGO IL 60646-6013
12327	FREEMAN CORP	9301 ALLEN DR	CLEVELAND OH 44125-4632
24931	SPECIALTY CONNECTOR CO INC	2100 EARLYWOOD DR PO BOX 547	FRANKLIN IN 46131
71400	BUSSMANN DIV OF COOPER INDUSTRIES INC	114 OLD STATE RD PO BOX 14460	ST LOUIS MO 63178
77900	ILLINOIS TOOL WORKS SHAKEPROOF DIV	ST CHARLES RD	ELGIN IL 60120
78189	ILLINOIS TOOL WORKS INC SHAKEPROOF DIV	ST CHARLES ROAD	ELGIN IL 60120
80009	TEKTRONIX INC	14150 SW KARL BRAUN DR PO BOX 500	BEAVERTON OR 97077-0001
83385	MICRODOT MFG INC GREER-CENTRAL DIV	3221 W BIG BEAVER RD	TROY MI 48098
93907	TEXTRON INC CAMCAR DIV	600 18TH AVE	ROCKFORD IL 61108-5181
TK0435	LEWIS SCREW CO	4300 S RACINE AVE	CHICAGO IL 60609-3320
TK0858	STAUFFER SUPPLY CO (DIST)	810 SE SHERMAN	PORTLAND OR 97214
TK1319	MORELLIS Q & D PLASTICS	1812 16-TH AVE	FOREST GROVE OR 97116
TK2165	TRIQUEST CORP	3000 LEWIS AND CLARK HWY	VANCOUVER WA 98661-2999
TK2278	COMTEK MANUFACTURING OF OREGON (METALS)	PO BOX 4200	BEAVERTON OR 97076-4200

Fig. & Index No.	Tektronix Part No.	Serial/Assembly No.		Qty	12345 Name & Description	Mfr.	
		Effective	Discnt			Code	Mfr. Part No.
1-1	334-6734-00			1	MARKER, IDENT:MKD 2247A, HANDLE	80009	334-6734-00
-2	337-2395-00			2	SHIELD, ELEC:HANDLE	80009	337-2395-00
					ATTACHING PARTS		
-3	213-0138-00			4	SCREW, TPG, TF:4-24 X 0.188, TYPE B, PNH, STL	TK0435	ORDER BY DESCR
					END ATTACHING PARTS		
-4	437-0390-00			1	CABINET ASSY:390-1057-00 W/FEET & HANDLE	80009	437-0390-00
-5	390-1057-01			1	.CABINET, SCOPE:EMI VERSION, ALUMINUM	80009	390-1057-01
-6	367-0289-00			1	.HANDLE, CARRYING:13.855, SST	80009	367-0289-00
					ATTACHING PARTS		
-7	212-0144-00			2	.SCREW, TPG, TF:8-16 X 0.562 L, PLASTITE, SPCL H	93907	225-38131-012
					.D		
					END ATTACHING PARTS		
-8	348-0659-00			2	.FOOT, CABINET:BLACK POLYURETHANE	TK2165	ORDER BY DESCR
-9	200-3660-00			1	COVER, AUTO CAL:POLYCARBONATE	80009	200-3660-00
-10	200-3728-00			1	COVER, REAR:W/LABELS	80009	200-3728-00
					ATTACHING PARTS		
-11	211-0691-00			4	SCREW, MACHINE:6-32 X 0.625, PNH, STL	TK0858	ORDER BY DESCR
					END ATTACHING PARTS		
-12	334-7316-00			1	MARKER, IDENT:MARKED TEK SAFTY CONTROLLED	80009	334-7316-00
	334-5258-00			1	MARKER, IDENT:MKD X-RAY WARNING, GERMAN	TK1694	ORDER BY DESCR
-13	334-6707-00			1	MARKER, IDENT:MKD CAUTION	80009	334-6707-00
-14	348-0764-04			1	SHLD GSKT, ELEK:0.125 X 0.188, WIRE MESH, 2	64411	28062000
					LAYERS, 37.0 L		

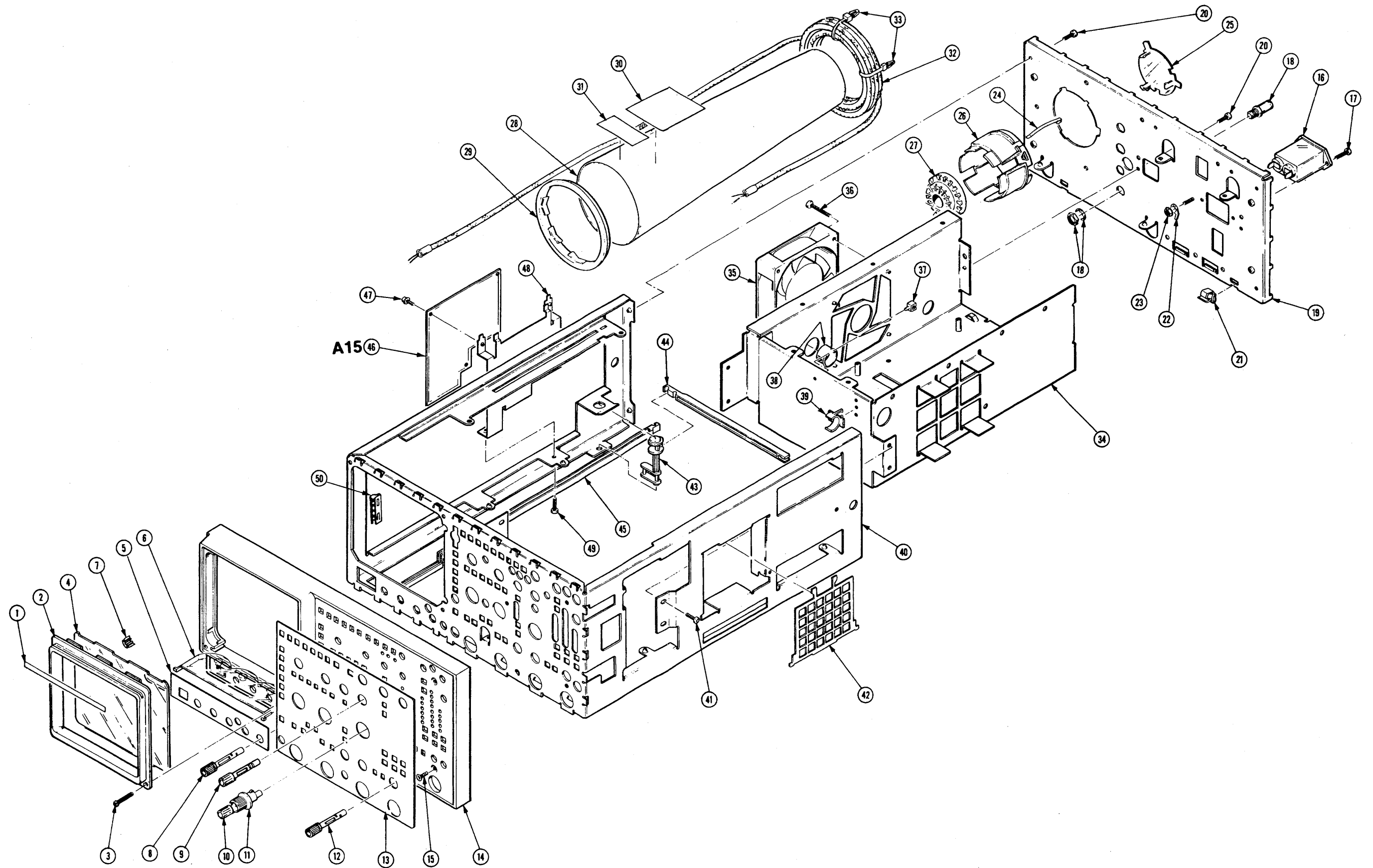

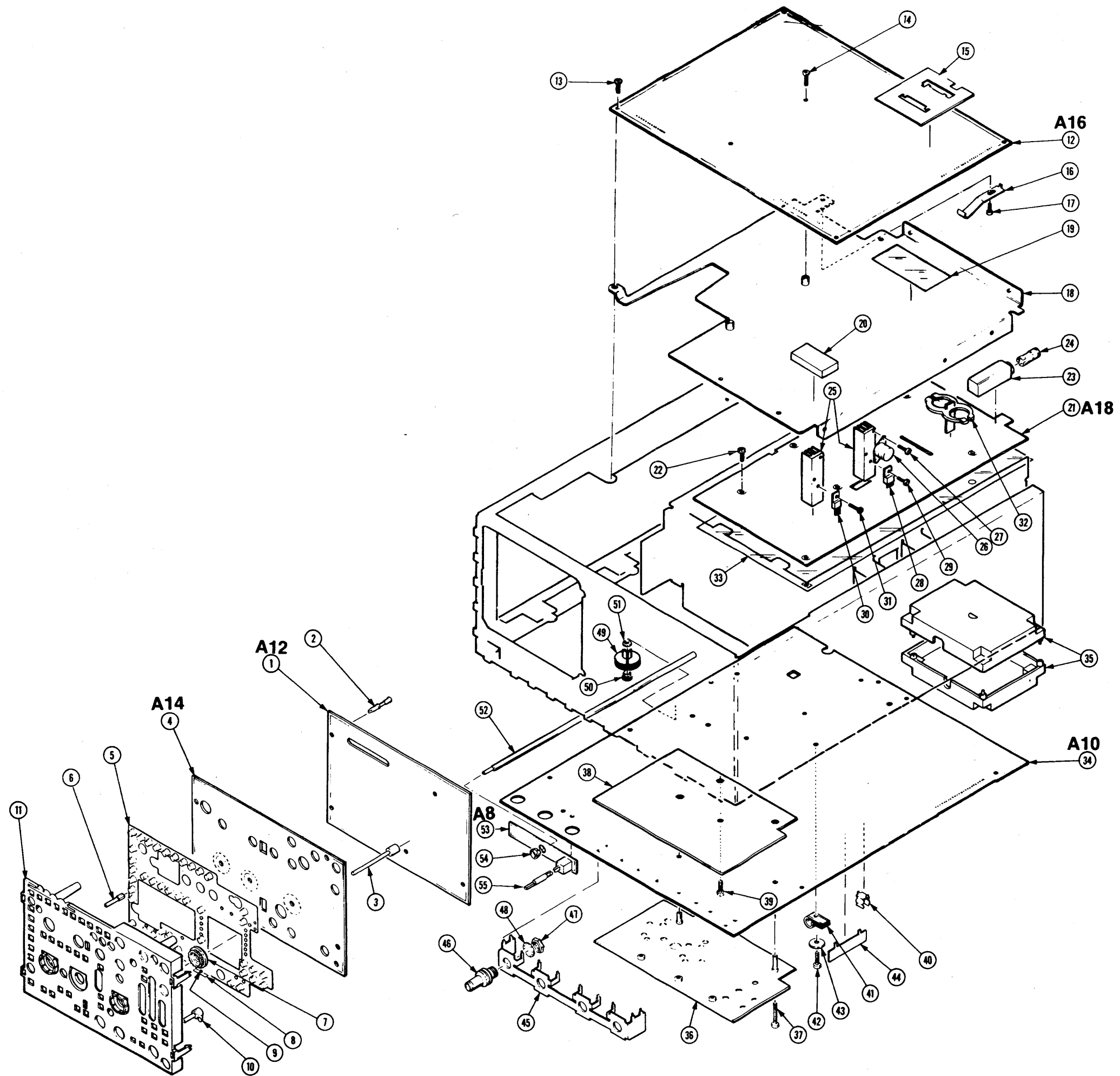

FIG.4 ACCESSORIES

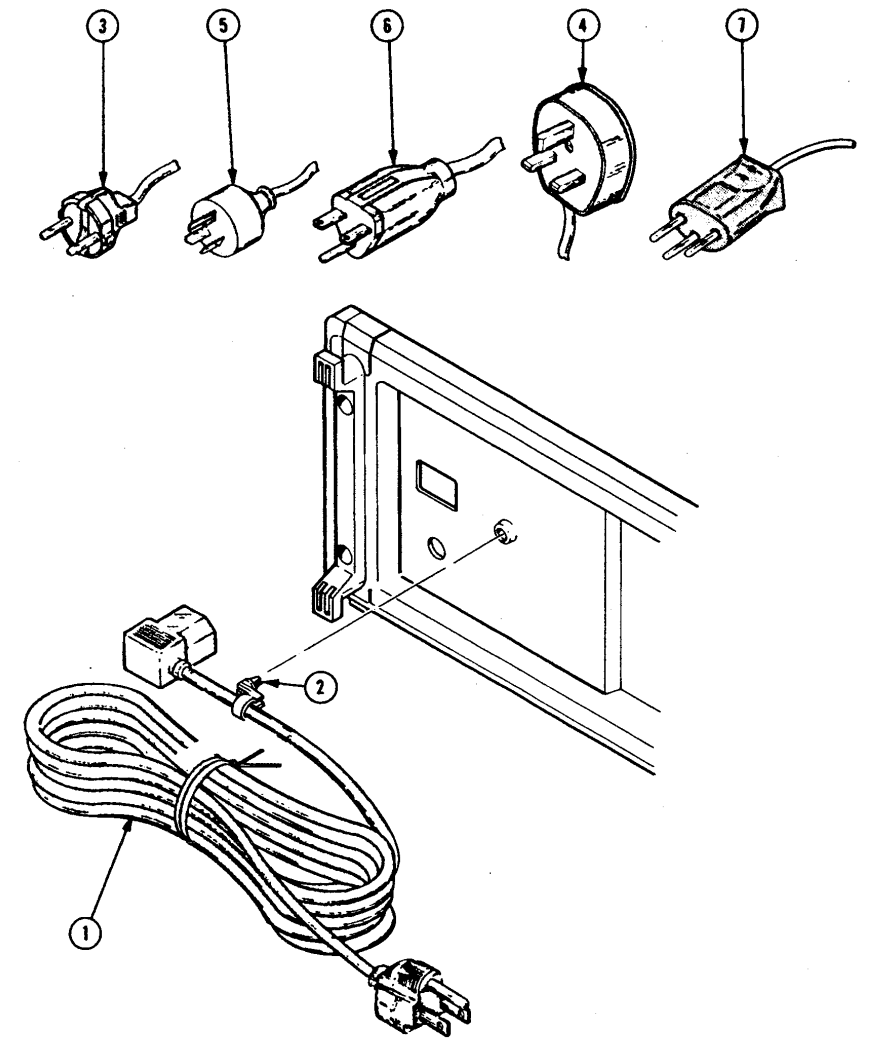

Fig. & Index No.	Tektronix Part No.	Serial/Assembly No.		Qty	12345 Name & Description	Mfr. Code	Mfr. Part No.	
		Effective	Discont					
2-1	334-6733-00			1	MARKER, IDENT:MKD 2247A	80009	334-6733-00	
-2	426-1765-02			1	FRAME,CRT:POLYCARBONATE,GRAY ATTACHING PARTS	TK2165	ORDER BY DESCR	
-3	211-0690-01			2	SCREW,MACHINE:6-32 X 0.875 PNH,SST END ATTACHING PARTS	86113	ORDER BY DESCR	
-4	337-2775-00			1	SHLD,IMPLOSION:FILTER,BLUE 2211/2213/2215	80009	337-2775-00	
-5	333-3290-00			1	PANEL,FRONT:	80009	333-3290-00	
-6	351-0752-00			1	GUIDE,LIGHT:ACRYLIC GRATICULE	80009	351-0752-00	
-7	348-0660-00			4	CUSHION,CRT:POLYURETHANE	80009	348-0660-00	
-8	366-2089-00			5	KNOB:GRAY,PUSH ON,0.185 ID X 0.392 OD X 0.4 95 H	80009	366-2089-00	
-9	366-2093-00			2	KNOB:DOVE GRAY,0.235 ID X 0.36 OD X 0.495H W/SHAFT PUSH	80009	366-2093-00	
-10	366-1510-00			3	KNOB:DOVE GRAY,VAR,0.127 ID X 0.392 OD X 0. 466 H	80009	366-1510-00	
-11	366-2090-00			3	KNOB:GRAY,VAR,0.2 ID X 0.546 OD X 0.69 H	80009	366-2090-00	
-12	366-2089-00			8	KNOB:GRAY,PUSH ON,0.185 ID X 0.392 OD X 0.4 95 H	80009	366-2089-00	
-13	333-3382-00			1	PANEL,FRONT:	80009	333-3382-00	
-14	386-3339-00			1	SUBPANEL,FRONT: ATTACHING PARTS	80009	386-3339-00	
-15	213-0882-00			2	SCREW,TPG,TR:6-32 X 0.437 TAPTITE,PNH,STL END ATTACHING PARTS	83385	ORDER BY DESCR	
-16	-----			1	FILTER,RFI: (SEE FL2201 REPL) ATTACHING PARTS			
-17	213-0882-00			2	SCREW,TPG,TR:6-32 X 0.437 TAPTITE,PNH,STL END ATTACHING PARTS	83385	ORDER BY DESCR	
-18	-----			1	CONN,RCPT,ELEC:BNC (SEE J16 REPL)			
-19	441-1791-00			1	CHASSIS,REAR: ATTACHING PARTS	TK2278	ORDER BY DESCR	
-20	213-0882-00			10	SCREW,TPG,TR:6-32 X 0.437 TAPTITE,PNH,STL END ATTACHING PARTS	83385	ORDER BY DESCR	
-21	343-1240-00			2	CLAMP,CABLE:0.25 ID,NYLON	TK1808	220-340802-00	
-22	441-1791-01	B020565		1	CHASSIS,REAR:EMI VERSION	TK2278	ORDER BY DESCR	
-23	210-0457-00			1	NUT,PL,ASSEM WA:6-32 X 0.312,STL CD PL	78189	511-061800-00	
	210-0006-00			1	WASHER,LOCK:#6 INTL,0.018 THK,STL END ATTACHING PARTS	77900	1206-00-00-0541C	
-24	214-1061-06			1	SPRING,GROUND:CRT SHIELD	80009	214-1061-06	
-25	200-2519-00			1	CAP,CRT SOCKET:NATURAL LEXAN	80009	200-2519-00	
-26	426-1766-00			1	MOUNT,RESILIENT:CRT,REAR	80009	426-1766-00	
-27	-----			1	WIRE SET,ELEC:SOCKET ASSY CRT (SEE A10W9)			
-28	337-2774-00			1	SHIELD,ELEC:CRCT,STEEL	23740	C-2059	
-29	386-4443-00			1	SUPPORT,SHIELD:CRT,FRONT,PLASTIC	80009	386-4443-00	
-30	334-1951-00			1	MARKER,IDENT:MKD WARNING,CRT VOLTAGES	22670	ORDER BY DESCR	
-31	334-1379-00			1	MARKER,IDENT:MKD HI VACUUM	07416	ORDER BY DESCR	
-32	-----			1	DELAY LINE,ELEC: (SEE DL21 REPL)			
-33	-----			1	LEAD,ELECTRICAL: (SEE W30 REPL) ATTACHING PARTS			
-34	441-1720-00			1	CHAS,PWR SUPPLY:GPSB	TK2278	ORDER BY DESCR	
-35	-----			1	FAN,TUBEAXIAL: (SEE B25 REPL) ATTACHING PARTS			
-36	213-0991-00			4	SCREW,TPG,TC:6-32 X 1.25 L,TYPE T,PNH,STL END ATTACHING PARTS	TK0858	ORDER BY DESCR	
-37	343-1305-00			1	CLP,WIRE SADDLE:0.437 ID,NYLON	06915	WS-1N	
-38	348-0532-00			2	GROMMET,PLASTIC:BLACK,ROUND,0.625 ID	28520	SB-750-10	
-39	344-0347-00			1	CLIP,ELECTRICAL:ANODE,0.72 OD,NYLON	TK2165	ORDER BY DESCR	
-40	441-1719-03			1	CHASSIS,MAIN:ALUMINUM ATTACHING PARTS	80009	441-1719-03	
-41	213-0882-00			6	SCREW,TPG,TR:6-32 X 0.437 TAPTITE,PNH,STL END ATTACHING PARTS	83385	ORDER BY DESCR	
-42	378-0295-00			1	GRILLE,AIR DUCT:ALUMINUM	TK2278	ORDER BY DESCR	
-43	214-3835-00			1	ARM,PIVOT:POWER SWITCH	80009	214-3835-00	
-44	384-1697-00			1	EXTENSION SHAFT:6.25 L X 0.285 OD,NYLON	80009	384-1697-00	
-45	384-1696-01			1	EXTENSION SHAFT:13.341 L X 0.285 OD,PC	TK1908	ORDER BY DESCR	
-46	-----			1	CIRCUIT BD ASSY:DAC SUBSYS (SAEE A15 REPL) ATTACHING PARTS			
-47	213-0881-00			3	SCREW,TPG,TR:6-32 X 0.25 TYPE TT,FILH,STL END ATTACHING PARTS	83385	ORDER BY DESCR	

Replaceable Mechanical Parts - 2247A Service

Fig. & Index No.	Tektronix Part No.	Serial/Assembly No. Effective Dscont	Qty	12345 Name & Description	Mfr. Code	Mfr. Part No.
2-48	407-3671-00		1	BRACKET,CKT BD:ALUMINUM ATTACHING PARTS	TK2278	ORDER BY DESCR
-49	213-0882-00		1	SCREW,TPG,TR:6-32 X 0.437 TAPTITE,PNH,STL END ATTACHING PARTS	83385	ORDER BY DESCR
-50	344-0367-01		2	CLIP,GROUND:CU-BE	80009	344-0367-01

Fig. & Index No.	Tektronix Part No.	Serial/Assembly No.		Qty	12345 Name & Description	Mfr.	
		Effective	Dscont			Code	Mfr. Part No.
3-1	-----			1	CIRCUIT BD ASSY:POTENTIOMETER (SEE A12) ATTACHING PARTS		
-2	214-3826-00 348-0904-00			7 7	LATCH,PLUNGER:BLACK GROMMET,FSTNR:0.187 DIA,BLACK END ATTACHING PARTS	80009 83014	214-3826-00 HN3G-32-1
-3	376-0130-00			3	COUPLER,SHAFT:2.260 L X 0.132 ID, POLYCARBONATE	80009	376-0130-00
-4	-----			1	CIRCUIT BD ASSY:SWITCH (SEE A14 REPL)		
-5	260-2271-00			1	SWITCH,PUSH:42 BUTTON,2 POLE	80009	260-2271-00
-6	366-2088-00			24	PUSH BUTTON:GRAY,0.172 SQ X 0.3 H	80009	366-2088-00
-7	105-0984-01			3	ACTR SWITCH AS:W/CONTACT	80009	105-0984-01
-8	214-1126-01			3	SPRING,FLAT:0.7 X 0.125,CU BE GRN CLR	80009	214-1126-01
-9	214-0274-00			3	BALL,BEARING:0.125 DIA,SST,GRADE 100	52676	ORDER BY DESCR
-10	366-2091-00			17	PUSH BUTTON:CLEAR,0.312 DIA X 0.3 H	80009	366-2091-00
-11	380-0767-00			1	HOUSING,SWITCH:POLYCARBONATE	80009	380-0767-00
-12	-----			1	CIRCUIT BD ASSY:PROCESSOR (SEE A16 REPL) ATTACHING PARTS		
-13	213-0882-00			12	SCREW,TPG,TR:6-32 X 0.437 TAPTITE,PNH,STL	83385	ORDER BY DESCR
-14	211-0691-00			2	SCREW,MACHINE:6-32 X 0.625,PNH,STL END ATTACHING PARTS	TK0858	ORDER BY DESCR
-15	214-4142-00			1	HT SK,MICROCKT:ALUMINUM	80009	214-4142-00
-16	131-1428-00			1	CONTACT,ELEC:GROUNDING,CU BE CD PL ATTACHING PARTS	80009	131-1428-00
-17	213-0882-00			1	SCREW,TPG,TR:6-32 X 0.437 TAPTITE,PNH,STL END ATTACHING PARTS	83385	ORDER BY DESCR
-18	337-3290-01			1	SHIELD,ELEC:TOP,W/CAUTION LABEL	80009	337-3290-01
-19	334-4251-00			1	MARKER,IDENT:MKD CAUTION	07416	ORDER BY DESCR
-20	361-1427-00			2	SPACER,CABLE:SILICONE	80009	361-1427-00
-21	-----			1	CIRCUIT BD ASSY:LVPS (SEE A18 REPL) ATTACHING PARTS		
-22	213-0882-00			6	SCREW,TPG,TR:6-32 X 0.437 TAPTITE,PNH,STL END ATTACHING PARTS	83385	ORDER BY DESCR
	214-3796-00			2	CIRCUIT BD ASSY INCLUDES: .HEAT SINK,XSTR:ALUMINUM,TO-220 (USE W/A18Q2209 & A18Q2210)	30161	5968B
-23	204-0906-00			1	.BODY,FUSEHOLDER:3AG & 5 X 20MM FUSES	S3629	TYPEFAU031.3573
-24	200-2264-00			1	.CAP,FUSEHOLDER:3AG FUSES	S3629	FEK 031 1666
-25	214-3821-00			2	.HEAT SINK,XSTR:PWR SPLY,GOLD W/CHROMATE PL	80009	214-3821-00
-26	-----			1	.SWITCH,THRMSTC: (SEE A18S2202 REPL) ATTACHING PARTS		
-27	213-0882-00			2	.SCREW,TPG,TR:6-32 X 0.437 TAPTITE,PNH,STL END ATTACHING PARTS	83385	ORDER BY DESCR
-28	-----			1	.TRANSISTOR: (SEE A18Q2201 REPL) ATTACHING PARTS		
-29	213-0882-00			1	.SCREW,TPG,TR:6-32 X 0.437 TAPTITE,PNH,STL END ATTACHING PARTS	83385	ORDER BY DESCR
-30	-----			1	.TRANSISTOR: (SEE A18Q2214 REPL) ATTACHING PARTS		
-31	213-0882-00			1	.SCREW,TPG,TR:6-32 X 0.437 TAPTITE,PNH,STL END ATTACHING PARTS	83385	ORDER BY DESCR
-32	344-0410-00 344-0410-02	B010100 B010731	B010730	1 1	.CLIP,COIL SPRT:1 X 1.46,POLYCARBONATE .CLIP,COIL SPRT:1.0 X 1.46,POLYCARBONATE	TK1319 TK1908	ORDER BY DESCR ORDER BY DESCR
-33	342-0781-00			1	INSUL,PWR SPLY:POLYCARBONATE	80009	342-0781-00
-34	-----			1	CIRCUIT BD ASSY:MAIN (SEE A10 REPL)		
-35	337-3342-02			2	.SHIELD,ELEC:HIGH VOLTAGE,2246	80009	337-3342-02
-36	337-3358-01			1	.SHIELD,ATTEN:FRONT,MAIN BD ATTACHING PARTS	80009	337-3358-01
-37	211-0690-01			2	.SCREW,MACHINE:6-32 X 0.875 PNH,SST END ATTACHING PARTS	86113	ORDER BY DESCR
-38	337-3279-00			1	.SHIELD,ATTEN:ALUMINUM ATTACHING PARTS	TK1938	ORDER BY DESCR
-39	213-0882-00			10	.SCREW,TPG,TR:6-32 X 0.437 TAPTITE,PNH,STL END ATTACHING PARTS	83385	ORDER BY DESCR
-40	344-0286-00			6	.CLIP,ELECTRICAL:FUSE,SPR BRS	75915	102074
-41	343-0003-00			1	.CLAMP,LOOP:0.25 ID,PLASTIC ATTACHING PARTS	06915	E4 CLEAR ROUND
-42	213-0882-00			1	.SCREW,TPG,TR:6-32 X 0.437 TAPTITE,PNH,STL	83385	ORDER BY DESCR

Replaceable Mechanical Parts - 2247A Service

Fig. & Index No.	Tektronix Part No.	Serial/Assembly No. Effective Dscort	Qty	12345 Name & Description	Mfr. Code	Mfr. Part No.
3-43	210-0949-00		1	.WASHER,FLAT:0.141 ID X 0.5 OD X 0.062,BRS END ATTACHING PARTS	12327	ORDER BY DESCR
-44	337-0896-00		2	.PLATE,ELEC SHLD:B SWEEP CKT BD	TK2278	ORDER BY DESCR
-45	407-3416-00		1	.BRACKET,ATTEN:BRASS	80009	407-3416-00
-46	-----		1	.CONN,RCPT,ELEC:BNC,MALE .(SEE A10J11,J12,J13,J14 REPL) ATTACHING PARTS		
-47	220-0497-00		4	.NUT,PLAIN,HEX:0.5-28 X 0.562 HEX,BRS CD PL	80009	220-0497-00
-48	210-1039-00		4	.WASHER,LOCK:0.521 ID,INT,0.025 THK,SST END ATTACHING PARTS	24931	ORDER BY DESCR
-49	214-3136-00		2	.HEAT SINK,XSTR:TO-5,ALUMINUM	80009	214-3136-00
-50	358-0715-00		2	.BUSHING,SNAP:0.25 ID X 0.234 THK,NYLON, 0.3 .75 OD	28520	2810
-51	342-0324-00		2	.INSULATOR,DISK:TRANSISTOR,NYLON	80009	342-0324-00
-52	384-1702-00		1	.EXTENSION SHAFT:9.97 L X 0.25,POLYIMIDE	80009	384-1702-00
-53	-----		1	.CIRCUIT BD ASSY:CRT CONTROL (SEE A8 REPL)		
-54	358-0715-00		1	.BUSHING,SNAP:0.25 ID X 0.234 THK,NYLON, 0.3 .75 OD	28520	2810
-55	384-1713-00		4	.EXTENSION SHAFT:0.918 L X 0.218 OD,PLASTIC	80009	384-1713-00

Fig. & Index No.	Tektronix Part No.	Serial/Assembly No. Effective	Discont	Qty	12345	Name & Description	Mfr. Code	Mfr. Part No.
4-								
STANDARD ACCESSORIES								
	-----			1		ACCESSORY PKG:TWO P6109 OPT 01 PROBES		
	070-6373-00			1		MANUAL, TECH:OPERATORS, 2247A	80009	070-6373-00
	070-6688-00			1		CARD, INFO:REFERENCE, 2247A	80009	070-6688-00
	159-0023-00			1		FUSE, CARTRIDGE:3AG, 2A, 250V, SLOW BLOW	71400	MDX2
-1	161-0230-01			1		CABLE ASSY, PWR, :3, 18 AWG, 92.0 L	80009	161-0230-01
-2	343-1213-00			1		CLAMP, PWR CORD:POLYIMIDE	80009	343-1213-00
-3	161-0104-06			1		CABLE ASSY, PWR, :3 X 0.75MM SQ, 220V, 98.0 L (OPTION A1 - EUROPEAN)	S3109	ORDER BY DESCR
-4	161-0104-07			1		CABLE ASSY, PWR, :3 X 0.75MM SQ, 240V, 98.0 L (OPTION A2 - UNITED KINGDOM)	80009	161-0104-07
-5	161-0104-05			1		CABLE ASSY, PWR, :3, 18 AWG, 240V, 98.0 L (OPTION A3 - AUSTRALIAN)	S3109	ORDER BY DESCR
-6	161-0104-08			1		CABLE ASSY, PWR, :3, 18 AWG, 240V, 98.0 L (OPTION A4 - NORTH AMERICAN)	70903	ORDER BY DESCR
-7	161-0167-00			1		CABLE ASSY, PWR, :3.0 X 0.75, 6A, 240V, 2.5M L (OPTION A5 - SWISSW)	80009	161-0167-00
OPTIONAL ACCESSORIES								
	016-0857-00			1		ACCESSORY POUCH:W/PLATE	TK0174	ORDER BY DESCR
	020-1515-00			1		COMPONENT KIT:2246, POUCH & COVER	80009	020-1515-00
	070-6367-00			1		MANUAL, TECH:SERVICE, 2247A	80009	070-6367-00
	200-3232-00			1		COVER, FRONT:	80009	200-3232-00

*This Document is a complete Scan from the original
Tektronix manual*

*For enquiries about our complete
High quality line of technical Manuals in PDF*

mailto : Qservice@otenet.gr

**SEE
OTHER
SIDE**

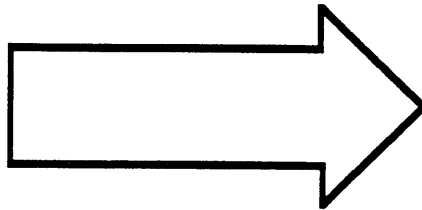

Manual Insert Status

DATE	CHANGE REFERENCE	STATUS
MAR 89	C1/0389	Effective
APR 89	M68887 (REV)	Effective
OCT 89	C3/1089	Effective
NOV 89	C4/1189	Effective
MAR 90	M68805	Effective
MAR 90	M71374	Effective
MAR 90	M71945	Effective
MAR 90	M71784	Effective
MAR 90	M68361	Effective
MAY 90	C2/0589 (REV)	Effective
JUN 90	M72115	Effective
NOV 90	C5/1190	Effective
DEC 90	M72008 (with Z)	Effective
APR 91	M70911	Effective
APR 91	M72728	Effective
MAY 91	M71502	Effective
MAY 91	M71065	Effective
MAY 91	C6/0591	Effective
MAY 91	M73905	Effective
MAY 91	M73903	Effective
MAY 91	M74238	Effective
MAY 91	M74062	Effective
JUN 91	C7/0691	Effective
JUN 91	M72472 (REV)	Effective
SEP 91	C8/0991	Effective
SEP 91	C9/0991	Effective
DEC 91	M76396	Effective
OCT 92	C10/1092	Effective
DEC 92	C11/1292	Effective
FEB 93	M78004	Effective
JUN 93	M77730	Effective

*This Document is a complete Scan from the original
Tektronix manual*

*For enquiries about our complete
High quality line of technical Manuals in PDF*

mailto : Qservice@otenet.gr

**SEE
OTHER
SIDE**

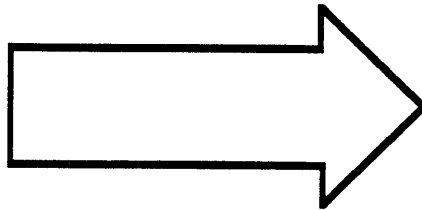

DESCRIPTION

Product Group 46

EFFECTIVE ALL SERIAL NUMBERS

TEXT CHANGES

Page 5-11 Horizontal Step 3. Readout Horizontal Gain (R823) and MAG Registration (R809)

Replace Step 3 entirely with the following procedure:

3. Readout Horizontal Gain (R823) and MAG Registration (R809)

- a. Set time mark generator for 0.5 ms time marks.
- b. Position the middle time marker to the center vertical graticule line using the Horizontal POSITION control.
- c. Set X10 MAG to Off.
- d. ADJUST—MAG REG (R809) to position the middle time marker to the center vertical graticule line.
- e. Set X10 MAG to On.
- f. CHECK—for no horizontal shift in the time marker.
- g. Repeat parts b through f until no shift is noted.
- h. Set:
 - i. Select Time CURSORS. Press the TIME MEASUREMENT button and select ← SEC → from the menu.
 - j. Rotate the ← OR DELAY control to align the cursor to the second graticule line.
 - k. Rotate the → control so that the reading is 400.0 μs.
 - l. ADJUST—both the ← OR DELAY control and R823 so that the cursors are aligned exactly on the second and tenth graticule line.
 - m. Set A INTEN to 10 o'clock.

X10 MAG	Off
SEC/DIV	50 μs
A INTEN	CCW (off)

*This Document is a complete Scan from the original
Tektronix manual*

*For enquiries about our complete
High quality line of technical Manuals in PDF*

mailto : Qservice@otenet.gr

**SEE
OTHER
SIDE**

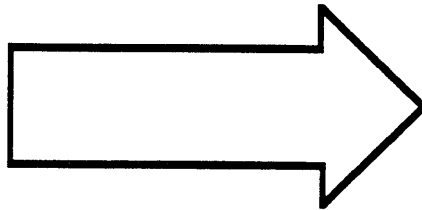

DESCRIPTION

Product Group 46

EFFECTIVE SERIAL NUMBER: B010600

TEXT CHANGES

Page 1-6, 1-7 **A AND B TRIGGER**

Replace the Characteristics and Performance Requirements for the A AND B TRIGGER specifications with the specifications contained in this insert.

CHARACTERISTICS

PERFORMANCE REQUIREMENTS

A TRIGGER

Sensitivity – CH 1 through CH 4;
AUTO LEVEL, AUTO, NORM, and
SGL SEQ

Trigger sensitivity is defined as the minimum peak-to-peak sine-wave trigger signal amplitude required to show the test signal with horizontal jitter of less than 3.0% of one period (p-p viewed over two seconds), with Trigger LEVEL control set at midlevel, but not at control extremes.

COUPLING

DC

0.35 division from dc to 25 MHz, increasing to 1.0 division at 150 MHz (100 MHz in AUTO LEVEL).

NOISE REJECT

1.4 division from dc to 25 MHz; increasing to 2.2 divisions at 100 MHz.
0.5 division or less will not trigger.

HF REJECT

0.35 division from dc to 50 kHz; attenuates signals above upper -3 dB cutoff frequency of 70 kHz.

LF REJECT

0.35 division from 100 kHz to 25 MHz, increasing to 1.0 division at 150 MHz (100 MHz in AUTO LEVEL); attenuates signals below the lower -3 dB cutoff frequency of 50 kHz.

AC

0.35 division from 50 Hz to 25 MHz, increasing to 1.0 division at 150 MHz; (100 MHz in AUTO LEVEL); attenuates signals below the lower -3 dB cutoff frequency of 20 Hz.

TV LINE, TV FIELD

0.5 division of composite sync will achieve a stable display.

HOLDOFF Control Range

Increases A Sweep holdoff time by at least a factor of 10.^a

MANUAL CHANGE INFORMATION

Product: 2247A SERVICE Date: 4-27-89 Change Reference: M68887(REV)

DESCRIPTION

Product Group 46

B TRIGGER

Sensitivity—CH 1 through CH 4; AUTO LEVEL, and NORM	Trigger sensitivity is defined as the minimum peak-to-peak sine-wave trigger signal amplitude required to show the test signal with horizontal jitter of less than 3.0% of one period (p-p viewed over two seconds), with Trigger LEVEL control set at midlevel, but not at control extremes.
COUPLING	
DC	0.35 division from dc to 10 MHz; increasing to 1.0 division at 150 MHz (100 MHz in AUTO LEVEL).
NOISE REJECT	1.4 division from dc to 10 MHz; increasing to 2.2 divisions at 100 MHz. 0.5 division or less will not trigger.
HF REJECT	0.35 division from dc to 50 kHz; attenuates signals above upper -3 dB cutoff frequency of 70 kHz.
LF REJECT	0.35 division from 100 kHz to 10 MHz; increasing to 1.0 division at 150 MHz (100 MHz in AUTO LEVEL); attenuates signals below the lower -3 dB cutoff frequency of 50 kHz.
AC	0.35 division from 50 Hz to 10 MHz; increasing to 1.0 division at 150 MHz (100 MHz in AUTO LEVEL); attenuates signals below the lower -3 dB cutoff frequency of 20 Hz.
TV LINE	0.5 division of composite sync will achieve a stable display.

A AND B TRIGGER

Channel Isolation (attenuation of deselected channel)	
CH 1 or CH 2 to Any Other Channel	20 dB or more at 100 MHz. ^a
CH 3 or CH 4 to Any Other Channel	30 dB or more at 100 MHz. ^a
Free Run Enable Frequency	
AUTO and AUTO LEVEL	The sweep will free run if trigger source frequency is less than 10 Hz. ^a In AUTO LEVEL, if the trigger-source frequency is ≤ 25 Hz, the range of the Trigger LEVEL control may be reduced.
LEVEL Control Range	
AUTO, NORM, and SGL SEQ	± 20 divisions referred to the appropriate vertical input. This range is sufficient to allow triggering at any point on a displayed waveform for all modes except ADD. In ADD, the combined range of the two position controls exceeds the trigger level range, making it possible (though unlikely) to pull a signal on screen for display but fail to trigger on it due to insufficient trigger level range.
AUTO LEVEL	Does not exceed the peak-to-peak amplitude of the trigger signal that was present when the AUTO LEVEL limits were set. ^a
TRIGGER LEVEL READOUT Accuracy	$\pm (0.3\% \text{ of reading} + 10\% \text{ of one vertical division}).^a$

^a Performance Requirement not checked in manual.

MANUAL CHANGE INFORMATION

Product: 2247A SERVICE Date: 4-27-89 Change Reference: M68887(REV)

DESCRIPTION

Product Group 46

REPLACEABLE ELECTRICAL PARTS LIST CHANGES

ADD:

A10C496	281-0864-00	CAP,FXD,CER DI: 430PF,5%,100V
A10C490	281-0864-00	CAP,FXD,CER DI: 430PF,5%,100V
A10C417	281-0915-00	CAP,FXD,CER DI: 1.8PF,+/- .25PF,200V

CHANGE TO:

A10R487	313-1027-00	RES,FXD,FILM: 2.7 OHM,5%,0.2W
A10U421	234-0239-31	QUICK CHIP: TRIGGER CIRCUIT, W/AU LEAD FRAME
A10U431	234-0239-31	QUICK CHIP: TRIGGER CIRCUIT, W/AU LEAD FRAME
A10X421	136-1065-00	SKT,PL-IN ELEK: MICROCKT,28 PIN LOW PROFILE
A10X431	136-1065-00	SKT,PL-IN ELEK: MICROCKT,28 PIN LOW PROFILE

DIAGRAM CHANGES

DIAGRAM A & B TRIGGER SYSTEM

Add capacitor C496 (430 pF) to U431 between pins 10 and 13. Location is 8C.

Add capacitor C490 (430 pF) to U431 from pin 14 to circuit board ground. Location is 7C.

Add capacitor C417 (1.8 pF) in parallel with R417 (location 6M).

Change the value of resistor R487 (location 8L) to 2.7 Ω .

*This Document is a complete Scan from the original
Tektronix manual*

*For enquiries about our complete
High quality line of technical Manuals in PDF*

mailto : Qservice@otenet.gr

**SEE
OTHER
SIDE**

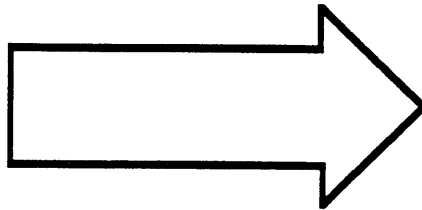

Date: 10-23-89

Change Reference: C3/1089

Product: 2247A SERVICE

Manual Part Number: 070-6367-00

DESCRIPTION

Product Group 46

EFFECTIVE ALL SERIAL NUMBERS

TEXT CHANGES

Page 1-5 HORIZONTAL DEFLECTION SYSTEM

Replace the Characteristics and Performance Requirement for "Sweep Linearity" with the following:

<p>Sweep Linearity 0.5 s/div to 5 ns/div 2 ns/div</p>	<p>± 5% ± 15%</p> <p>Sweep Linearity applies over the center eight divisions. Excludes the first 1/4 division or 25 ns from the start of the magnified sweep and anything beyond the 100th magnified division.</p>
---	--

*This Document is a complete Scan from the original
Tektronix manual*

*For enquiries about our complete
High quality line of technical Manuals in PDF*

mailto : Qservice@otenet.gr

**SEE
OTHER
SIDE**

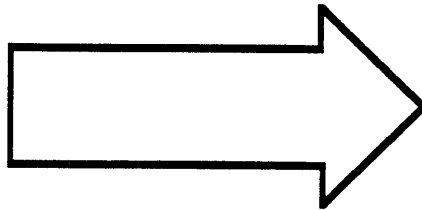

Date: 11-08-89

Change Reference: C4/1189

Product: 2247A SERVICE

Manual Part Number: 070-6367-00

DESCRIPTION

Product Group 46

EFFECTIVE ALL SERIAL NUMBERS

TEXT CHANGES

Page 1-5 VERTICAL DEFLECTION SYSTEM

Change:

Delay Match (CH 1 or CH 2 to
CH 3 or CH 4)

≤ 400 ps difference.

Page 4-10

Step 14. CH 1 to CH 4 Signal Delay Match

d. CHECK— that the leading edges of the two waveforms have ≤ 0.2 horizontal divisions separation at the center graticule line excluding trace width.

*This Document is a complete Scan from the original
Tektronix manual*

*For enquiries about our complete
High quality line of technical Manuals in PDF*

mailto : Qservice@otenet.gr

**SEE
OTHER
SIDE**

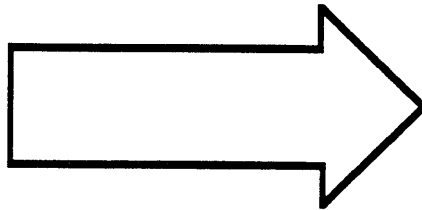

Date: 03-13-90 Change Reference: M68805

Product: 2247A SERVICE Manual Part Number: 070-6367-00

DESCRIPTION

Product Group 46

EFFECTIVE SERIAL NUMBERS: B020100

REPLACEABLE ELECTRICAL PARTS LIST CHANGE

A16 Processor board CHANGE:

A16U2519 160-6502-00 MICROCKT, DGTL: NMOS, EPROM, PRGM

REPLACEABLE MECHANICAL PARTS LIST CHANGE

FIG. 2 CHASSIS CHANGE:

Item			
	2-13	333-3747-00	PANEL, FRONT

*This Document is a complete Scan from the original
Tektronix manual*

*For enquiries about our complete
High quality line of technical Manuals in PDF*

mailto : Qservice@otenet.gr

**SEE
OTHER
SIDE**

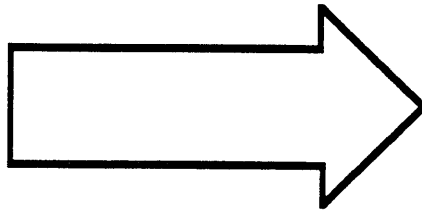

*This Document is a complete Scan from the original
Tektronix manual*

*For enquiries about our complete
High quality line of technical Manuals in PDF*

mailto : Qservice@otenet.gr

**SEE
OTHER
SIDE**

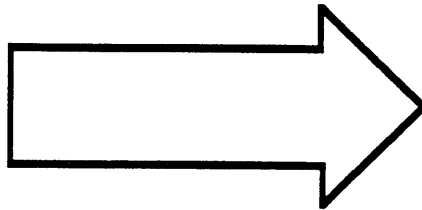

Date: 03-16-90 Change Reference: M71945

Product: 2247A SERVICE Manual Part Number: 070-6367-00

DESCRIPTION

Product Group 46

EFFECTIVE SERIAL NUMBERS: B022183

REPLACEABLE ELECTRICAL PARTS LIST CHANGE

A16 Processor board CHANGE:

A16U2519 160-6502-03 MICROCKT, DGTL: NMOS, EPROM, PRGM

*This Document is a complete Scan from the original
Tektronix manual*

*For enquiries about our complete
High quality line of technical Manuals in PDF*

mailto : Qservice@otenet.gr

**SEE
OTHER
SIDE**

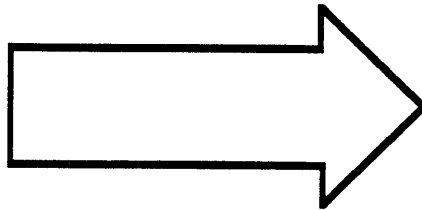

DESCRIPTION

Product Group 46

EFFECTIVE SERIAL NUMBERS: B022205

REPLACEABLE ELECTRICAL PARTS LIST CHANGE

A10 Main board

Change:

A10R932 322-3237-00 RES,FXD, FILM: 2.87K OHM,1%,0.2W,TC=T0.
A10R460 313-1681-00 RES,FXD, FILM: 680 OHM,5%, 0.2W.

Add:

A10R941 311-2229-00 RES,VAR, NONWW:TRMR,250OHM,20%
0.5W LINEAR

Delete:

A10W906 131-0566-00 BUS,CONNECTOR:DUMMY RES, 0.094 OD
X0.223L W/WIRELEADS.

DIAGRAM CHANGES

DIAGRAM 3 A & B TRIGGER SYSTEM

Change R460 to 680 ohm grid location 6K.

DIAGRAM 7 Z-AXIS, CRT. PROBE ADJ, & CONTROL MUX

The following list of changes to schematic 7 are illustrated with the partial schematic below.

Change value of R932 to 2.87K grid location 1H.

Add R941 250 ohm trimmer grid location 1H.

Remove W906 grid location 1H.

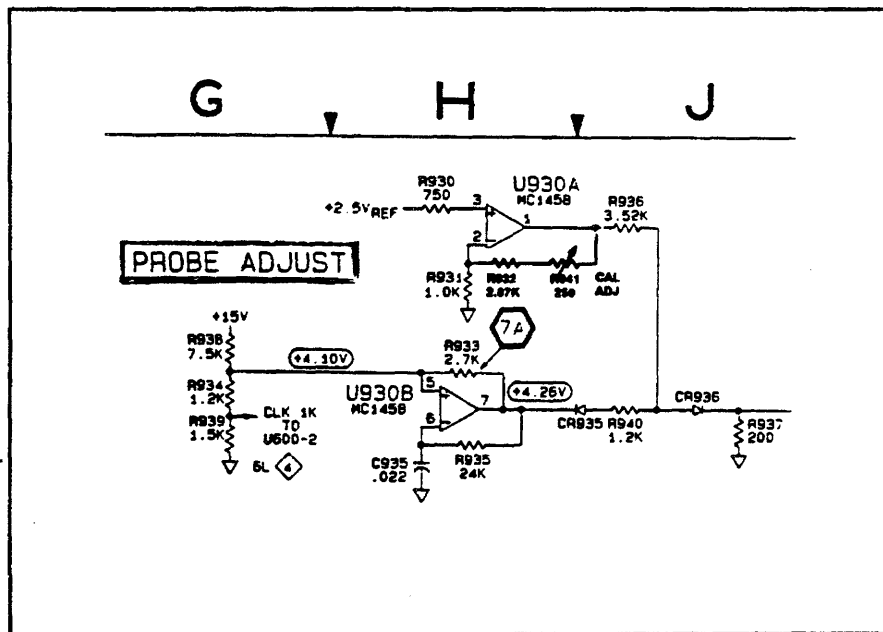

*This Document is a complete Scan from the original
Tektronix manual*

*For enquiries about our complete
High quality line of technical Manuals in PDF*

mailto : Qservice@otenet.gr

**SEE
OTHER
SIDE**

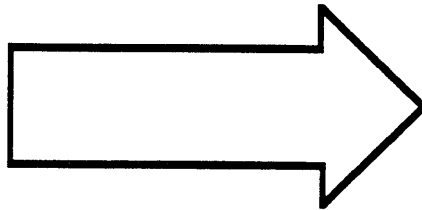

Date: 3-18-90 Change Reference: M68361

Product: 2247A SERVICE MANUAL Manual Part Number: 070-6367-00

DESCRIPTION

Product Group 46

EFFECTIVE SERIAL NUMBER: B020618

REPLACEABLE ELECTRICAL PARTS LIST CHANGES

CHASSIS PARTS

CHANGE TO:

B25 119-3564-00

FAN,TUBE,AXIAL: 12VDC,2.6W,3200 RPM,36 CFM

*This Document is a complete Scan from the original
Tektronix manual*

*For enquiries about our complete
High quality line of technical Manuals in PDF*

mailto : Qservice@otenet.gr

**SEE
OTHER
SIDE**

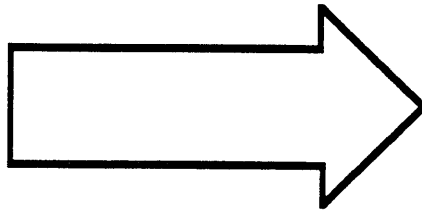

Date: 5-18-90

Change Reference: C2/0589 (Rev)

Product: 2247A SERVICE

Manual Part Number: 070-6367-00

DESCRIPTION

Product Group 46

EFFECTIVE SERIAL NUMBER: B010600

OPTION 15

THIS INSERT CONTAINS ALL INFORMATION REGARDING OPTION 15 (CH 2 SIGNAL OUT AND A GATE OUT). THE ATTACHED PAGES (1 – 6) CONTAIN THE FOLLOWING INFORMATION:

**DESCRIPTION
SPECIFICATIONS
PERFORMANCE VERIFICATION CHECK
ADJUSTMENT PROCEDURE
REPLACEABLE PARTS LISTS
CH 2 SIGNAL OUT BOARD
SCHEMATIC DIAGRAMS**

*This Document is a complete Scan from the original
Tektronix manual*

*For enquiries about our complete
High quality line of technical Manuals in PDF*

mailto : Qservice@otenet.gr

**SEE
OTHER
SIDE**

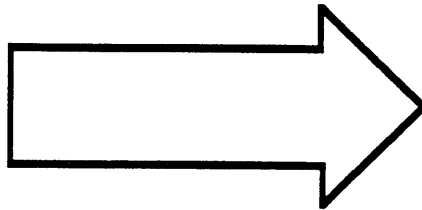

OPTION 15

DESCRIPTION

Option 15 adds two additional outputs to the rear panel of the instrument, CH 2 Signal Out and A GATE Out.

This document contains the Description, Specification, Performance Check, Adjustment Procedure, and Replaceable Parts information for Option 15. The schematic illustration of each circuit is also included with this document.

CH2 Signal Output

The CH 2 SIGNAL OUT Connector located on the rear-panel provides an output signal that is a normalized

representation of the Channel 2 input signal. The output amplitude into a 1 M Ω load is approximately 20 mV per division of input signal. Into a 50- Ω load, the output amplitude is approximately 10 mV per division of input signal.

A GATE Output

The A GATE OUT Connector located on the rear-panel provides a TTL and CMOS Compatible, positive-going gate signal that is HI during the A Sweep and LO when the A Sweep is not running.

SPECIFICATIONS

Electrical Characteristics

CHARACTERISTICS	PERFORMANCE REQUIREMENTS
CH 2 SIGNAL OUT	
Temperature Range	-10 to 55° C.
Dynamic Range	± 7 divisions.
Deflection Factor	
Into 50 Ω	10mV/div $\pm 10\%$.
Into 1 M Ω	20mV/div $\pm 10\%$.
3dB Bandwidth	DC to 25 MHz.
DC Offset (Adjusted)	< 0.5 div (measured at 2 mV/div).
A GATE OUTPUT	
Output Voltage	3.5 V to 5.25 V positive-going pulse starting at 0 V to 0.7 V.
Output Drive	Will supply 4 mA during HI state, will sink 20 mA during LO state. ^a

^a Performance Requirement not checked in manual.

PERFORMANCE VERIFICATION CHECK

Equipment Required	
Leveled Sine-Wave Generator Calibration Generator Test Oscilloscope	50-Ω BNC Precision Coaxial Cable 50-Ω BNC Coaxial Cable 50-Ω BNC Termination

1. CH 2 Signal Output

a. Set:

VERTICAL MODE	CH 1 and CH 2 (CH 3 and CH 4 Off)
BW LIMIT	Off
VOLTS/DIV	2 mV
Input Coupling	
CH 1 and CH 2	GND
A and B SEC/DIV	1ms
TRIGGER MODE	AUTO LVL
SOURCE	VERT
COUPLING	NOISE REJ

b. Push the CH 2 VERTICAL MODE button so that light is off.

c. Connect the CH 2 signal from the rear-panel CH 2 SIGNAL OUT connector to the CH 1 OR X input connector via a 50-Ω BNC cable.

d. Align the CH 1 trace to the center graticule line.

e. Set CH 1 Input Coupling to DC.

f. CHECK—Displayed trace is within 0.5 division of the ground reference set above (neglect trace width).

g. Connect a 1 kHz, 10 mV standard-amplitude signal from the Calibration Generator to the CH 2 Input Connector via a 50-Ω BNC cable.

h. Set CH 2 Input Coupling to DC.

i. Set CH 1 VOLTS/DIV to 20 mV.

j. CHECK—Display amplitude is 4.5 to 5.5 divisions (neglect trace width).

k. Connect a 50-Ω terminator to the CH 1 Input.

l. Set CH 1 VOLTS/DIV to 10 mV.

m. CHECK—Display amplitude is 4.5 to 5.5 divisions (neglect trace width).

n. Set CH 2 VOLTS/DIV to .1 V.

o. Connect a 50 kHz signal from the Leveled Sine-Wave Generator to the CH 2 input connector via a precision 50-Ω BNC cable and a 50-Ω Termination.

p. Adjust the generator output level to produce a 6-division CH 1 display.

q. Increase the generator frequency to 25 MHz.

r. CHECK—Display amplitude is 4.24 divisions or greater.

s. Disconnect the test setup.

2. A GATE Output

a. Set:

SEC/DIV	0.1 ms
TRIGGER MODE	Auto
HOLDOFF	Minimum (CCW)

b. Connect a test oscilloscope to the A GATE OUT Connector from the rear-panel via a 50-Ω BNC cable.

c. CHECK—Test oscilloscope displays a signal with a high level between 2 V and 5.25 V and a low level between 0 V and 0.7 V.

d. CHECK—Duration of the high level is greater than or equal to 0.2 ms.

e. Set HOLDOFF Control to maximum (CW).

f. CHECK—Duration of the high level is greater than or equal to 2 ms.

g. Disconnect the test setup.

ADJUSTMENT PROCEDURE

1. CH 2 Signal Output

NOTE

The CH 1 and CH 2 STEP BALANCE Adjustment Procedures (located in the Service Manuals Adjustment Procedure Section) must be completed before continuing with this procedure.

- a. Set CH 2 Input Coupling to GND.
- b. Connect the CH 2 signal from the rear-panel CH 2 SIGNAL OUT Connector to the CH 1 OR X input Connector via a 50- Ω BNC cable.

- c. Set CH 1 VOLTS/DIV to 2 mV.
- d. Set CH 1 Input Coupling to GND and align the trace with the center graticule line.
- e. Set CH 1 Input Coupling to DC.
- f. Adjust R1508 until the displayed trace is aligned with the reference set above (neglect trace width).

2. A GATE Output

There are no adjustments for the A GATE Output.

MAINTENANCE

A10—Main Board Replacement

When replacing the A10—Main Board with a new board, two diodes will need to be removed from the old

Main Board and added to the new board. These diode are CR601 and CR602. Refer to the A10—Main Board figure in this manual for location of these two diodes.

REPLACEABLE ELECTRICAL PARTS LIST

Component No.	Tektronix Part No.	Name & Description
A25	671-1153-00	CIRCUIT BD ASSY: CH 2 OUT OPT
A25C1500	281-0915-00	CAP,FXD,CER DI: 1.8PF,+/-0.25PF,200V
A25C1501	281-0909-00	CAP,FXD,CER DI: 0.022UF,20%,50V,TUBULAR,MI
A25C1502	281-0909-00	CAP,FXD,CER DI: 0.022UF,20%,50V,TUBULAR,MI
A25CR1500	152-0141-02	SEMICON DVC,DI: SW,SI,30V,150MA,30V,DO-35
A25CR1501	152-0141-02	SEMICON DVC,DI: SW,SI,30V,150MA,30V,DO-35
A25E1502	276-0635-00	CORE,EM: TOROID,FERRITE 0.5 OD X 0.281 ID X 0.2
A25J1501	131-0590-00	TERMINAL, PIN: 0.71 L X .025 SQ PH BRZ,GLD PL
A25J1503	131-0590-00	TERMINAL, PIN: 0.71 L X .025 SQ PH BRZ,GLD PL
A25J1504	131-0590-00	TERMINAL, PIN: 0.71 L X .025 SQ PH BRZ,GLD PL
A25J1505	136-0252-00	SOCKET,PIN TERM: U/W 0.019 DIA PINS
A25J1506	131-0955-00	CONN,RCPT,ELEC: BNC,FEMALE
A25R1500	313-1511-00	RES,FXD,FILM: 510 OHM,5%,0.2W
A25R1501	322-3184-00	RES,FXD,FILM: 806 OHM,1%,0.2W
A25R1502	322-3205-00	RES,FXD,FILM: 1.33K OHM,1%,0.2W
A25R1503	313-1121-00	RES,FXD,FILM: 120 OHM,5%,0.2W
A25R1504	313-1102-00	RES,FXD,FILM: 1K OHM,5%,0.2W
A25R1505	322-3068-00	RES,FXD,FILM: 49.9 OHM,1%,0.2W
A25R1507	322-3222-00	RES,FXD,FILM: 2K OHM,1%,0.2W
A25R1507	313-1132-00	RES,FXD,FILM: 1.3K OHM,5%,0.2W
A25R1508	311-2258-00	RES,VAR,NONWW: TRMR,1K OHM,20%,0.5
A25R1509	313-1101-00	RES,FXD,FILM: 100 OHM,5%,0.2W
A25U1500	156-0048-00	MICROCKT,LINEAR: 5 XSTR ARRAY,CA3046,14 DIR,MI
A25W1502	174-1649-00	CABLE ASSY,RF: 50 OHM COAX,16.0 L,W/HARMONICA,9-3
A10CR601	152-0141-02	SEMICON DVC,DI: SW,SI,30V,150MA,30V
A10CR602	152-0141-02	SEMICON DVC,DI: SW,SI,30V,150MA,30V
CHASSIS PARTS		
W1503	174-1841-00	LEAD,ELECTRICAL: 22 AWG,6.0 L,9-N,W/STRAIN RELIEF
J1507	131-0955-00	CONN,RCPT,ELEC: BNC,FEMALE

REPLACEABLE MECHANICAL PARTS LIST

Tektronix Part No.	Qty	Name & Description
361-1535-00	1	SPACER,SLEEVE: 0.45 L X 0.313 OD,AL
211-0690-01	1	SCREW,MACHINE: 6-32 X 0.875,PNH,SST,TORX
210-0255-00	2	TERMINAL,LUG: 0.391 ID,LOCKING,BRS CD PL
334-7486-00	1	MARKER,IDENT: MARKED Z AXIS A GATE OUT CH 2 OUT

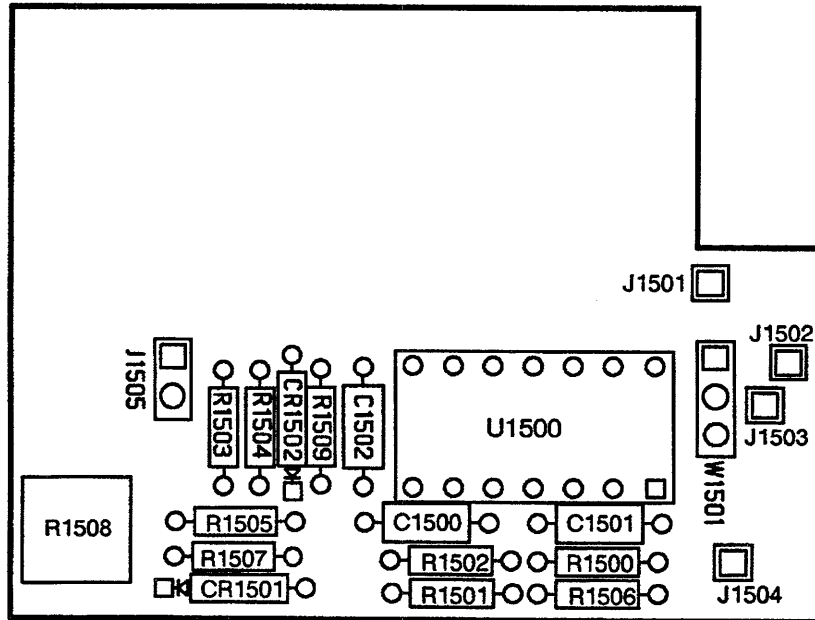

A25 CH 2 Signal Out Board.

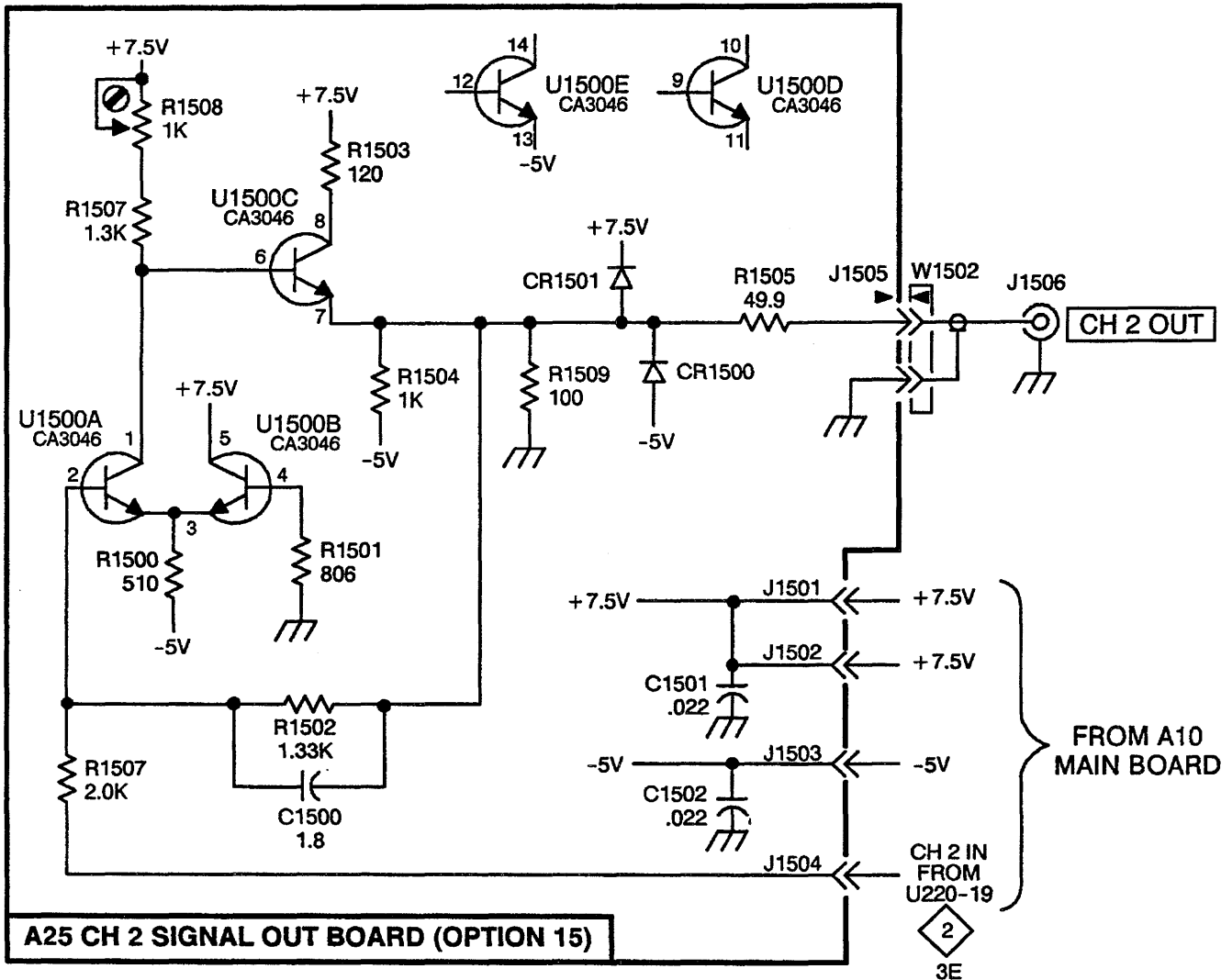

CH 2 Signal Out Diagram.

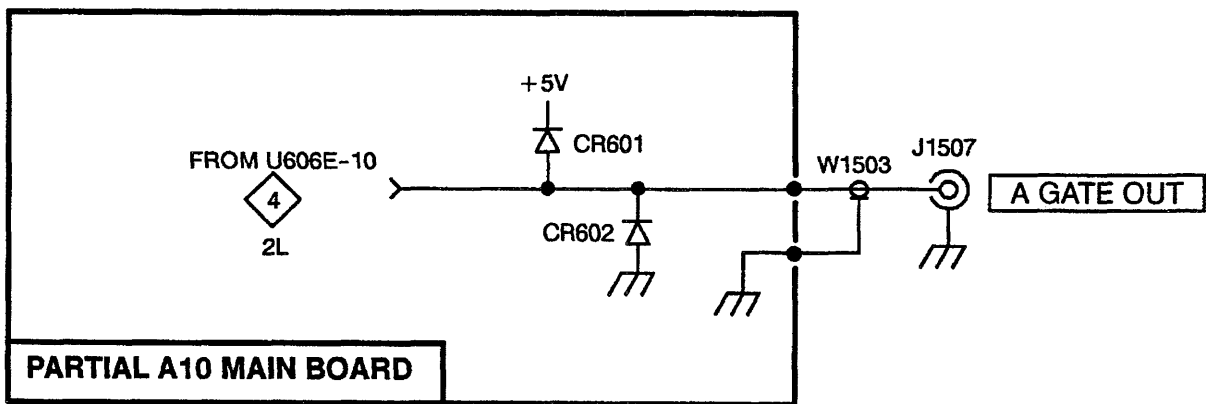

A Gate Out Diagram.

Date: 6-13-90

Change Reference: M72115

Product: 2247A SERVICE

Manual Part Number: 070-6367-00

DESCRIPTION

Product Group 46

EFFECTIVE SERIAL NUMBER: B022292

REPLACEABLE ELECTRICAL PARTS LIST CHANGES

A10 Main board

CHANGE TO:

A10C216	281-0775-01	CAP,FXD,CER DI: 0.1 UF,20%,50V
A10C217	281-0775-01	CAP,FXD,CER DI: 0.1 UF,20%,50V

DIAGRAM



**MAIN BOARD POWER
DISTRIBUTION**

Change the value of capacitor C216 to 0.1 UF (grid location B1).
Change the value of capacitor C217 to 0.1 UF (grid location B1).

*This Document is a complete Scan from the original
Tektronix manual*

*For enquiries about our complete
High quality line of technical Manuals in PDF*

mailto : Qservice@otenet.gr

**SEE
OTHER
SIDE**

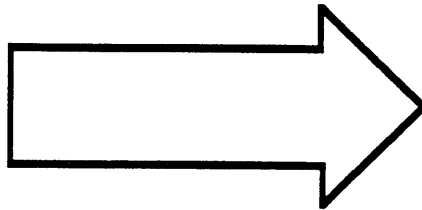

Date: 11-26-90Change Reference: C5/1190Product: 2247A SERVICEManual Part Number: 070-6367-00**DESCRIPTION**

Product Group 46

EFFECTIVE ALL SERIAL NUMBERS**Page 4-16 Step 4. 150 MHz Trigger Sensitivity**

Replace parts o through s of Step 4 with parts o through u shown below.

- | | |
|--|--|
| o. CHECK—that the display is stably triggered with NOISE REJ Trigger CPLG. | s. CHECK—that the display is not triggered in HF REJ Trigger CPLG. |
| p. Set leveled sine-wave generator output for a 0.5 division display amplitude at 100 MHz. | t. Set: |
| q. CHECK—that the display is not triggered in NOISE REJ Trigger CPLG. | TRIGGER CPLG DC |
| r. Set leveled sine-wave generator output for a 1.0 division display amplitude at 100 MHz. | Horizontal MODE B |
| | A/B SELECT B Trigger |
| | u. Repeat parts n through u for the B Trigger. |

*This Document is a complete Scan from the original
Tektronix manual*

*For enquiries about our complete
High quality line of technical Manuals in PDF*

mailto : Qservice@otenet.gr

**SEE
OTHER
SIDE**

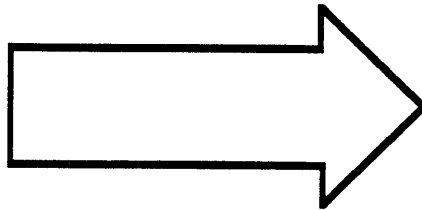

DESCRIPTION

Product Group 46

EFFECTIVE SERIAL NUMBER: B029000

REPLACEABLE ELECTRICAL PARTS LIST CHANGES

CHANGE TO:

A10	671-0422-03	CIRCUIT BD ASSY: MAIN
A10C275	281-0776-00	CAP,FXD,CER DI: 120PF,5%,100V
A10C496	283-0196-00	CAP,FXD,CER DI: 270PF,10%,50V
A10C425	283-0196-00	CAP,FXD,CER DI: 270PF,10%,50V
A10C485	283-0196-00	CAP,FXD,CER DI: 270PF,10%,50V
A10C705	285-1460-00	CAP,FXD,MTLZD: 0.1UF,20%,250V
A10C801	285-1460-00	CAP,FXD,MTLZD: 0.1UF,20%,250V
A10C802	285-1460-00	CAP,FXD,MTLZD: 0.1UF,20%,250V
A10C804	285-1460-00	CAP,FXD,MTLZD: 0.1UF,20%,250V
A10C809	285-1460-00	CAP,FXD,MTLZD: 0.1UF,20%,250V
A10C818	285-1460-00	CAP,FXD,MTLZD: 0.1UF,20%,250V
A10C1101	290-0183-00	CAP,FXD,ELCTLT: 1UF,10%,35V
A10C2708	285-1460-00	CAP,FXD,MTLZD: 0.1UF,20%,250V
A10C2709	285-1460-00	CAP,FXD,MTLZD: 0.1UF,20%,250V
A10C2710	285-1460-00	CAP,FXD,MTLZD: 0.1UF,20%,250V
A10C2717	285-1460-00	CAP,FXD,MTLZD: 0.1UF,20%,250V
A10C2783	285-1460-00	CAP,FXD,MTLZD: 0.1UF,20%,250V
A10C2785	285-1460-00	CAP,FXD,MTLZD: 0.1UF,20%,250V
A10CR201	152-1107-00	DIODE,SIG: SCHTKY,40V,350MA,12PF
A10CR202	152-1107-00	DIODE,SIG: SCHTKY,40V,350MA,12PF
A10R131	315-0620-00	RES,FXD,FILM: 62 OHM,5%,0.25W
A10R151	315-0620-00	RES,FXD,FILM: 62 OHM,5%,0.25W
A10R211	311-2232-00	RES,VAR,NONWW: TRMR,2K OHM,20%,0.5W
A10R221	311-2232-00	RES,VAR,NONWW: TRMR,2K OHM,20%,0.5W
A10R231	311-2232-00	RES,VAR,NONWW: TRMR,2K OHM,20%,0.5W
A10R241	311-2232-00	RES,VAR,NONWW: TRMR,2K OHM,20%,0.5W
A10R261	313-1473-00	RES,FXD,FILM: 47K OHM,5%,0.2W
A10R460	313-1681-00	RES,FXD,FILM: 680 OHM,5%,0.2W
A10R638	313-1104-00	RES,FXD,FILM: 100K OHM,5%,0.2W
A10R725	313-1751-00	RES,FXD,FILM: 750 OHM,5%,0.2W
A10R820	322-0402-00	RES,FXD,FILM: 150K OHM,1%,0.25W
A10R821	322-0402-00	RES,FXD,FILM: 150K OHM,1%,0.25W
A10U173	156-3944-00	MICROCKT,DGTL: CMOS, 8 BIT SHIFT REG LATCH,74HCT4094
A10U309	156-0158-00	MICROCKT,LINEAR: BIPOLAR,DUAL OPNL AMP,MC1458
A10U801	156-0158-00	MICROCKT,LINEAR: BIPOLAR,DUAL OPNL AMP,MC1458
A10U930	156-0158-00	MICROCKT,LINEAR: BIPOLAR,DUAL OPNL AMP,MC1458

MANUAL CHANGE INFORMATION

Product: 2247A SERVICE Date: 12-6-90 Change Reference: M72008

DESCRIPTION

Product Group 46

REPLACEABLE ELECTRICAL PARTS LIST CHANGES (cont)

REMOVE:

A10R250	307-0792-01	RES,NTWK,FXD,FI: (7) 82 OHM,2%,0.15W
A10R251	307-0792-01	RES,NTWK,FXD,FI: (7) 82 OHM,2%,0.15W
A10W202	131-0566-00	BUS,CONDUCTOR: DUMMY RES,0.094 OD X 0.225 L
A10W235	131-0566-00	BUS,CONDUCTOR: DUMMY RES,0.094 OD X 0.225 L
A10W612	131-0566-00	BUS,CONDUCTOR: DUMMY RES,0.094 OD X 0.225 L
A10W820	131-0566-00	BUS,CONDUCTOR: DUMMY RES,0.094 OD X 0.225 L
A10W821	131-0566-00	BUS,CONDUCTOR: DUMMY RES,0.094 OD X 0.225 L

ADD:

A10C488	283-0196-00	CAP,FXD,CER DI: 270PF,10%,50V
A10C490	283-0196-00	CAP,FXD,CER DI: 270PF,10%,50V
A10C636	281-0909-00	CAP,FXD,CER DI: 0.022UF,20%,50V
A10C1250	283-0853-00	CAP,FXD,CER DI: 2.2PF,200V
A10C1251	283-0853-00	CAP,FXD,CER DI: 2.2PF,200V
A10CR612	152-0141-02	SEMICON DVC,DI: SW,SI,30V,150MA,30V,DO-35
A10R216	313-1103-00	RES,FXD,FILM: 10K OHM,5%,0.2W
A10R217	313-1472-00	RES,FXD,FILM: 4.7K OHM,5%,0.2W
A10R249	313-1027-00	RES,FXD,FILM: 2.7 OHM,5%,0.2W
A10R925	313-1472-00	RES,FXD,FILM: 4.7K OHM,5%,0.2W
A10R1210	313-1101-00	RES,FXD,FILM: 100 OHM,5%,0.2W
A10R1211	313-1101-00	RES,FXD,FILM: 100 OHM,5%,0.2W
A10R1220	313-1101-00	RES,FXD,FILM: 100 OHM,5%,0.2W
A10R1221	313-1101-00	RES,FXD,FILM: 100 OHM,5%,0.2W
A10R1230	313-1101-00	RES,FXD,FILM: 100 OHM,5%,0.2W
A10R1231	313-1101-00	RES,FXD,FILM: 100 OHM,5%,0.2W
A10R1240	313-1101-00	RES,FXD,FILM: 100 OHM,5%,0.2W
A10R1241	313-1101-00	RES,FXD,FILM: 100 OHM,5%,0.2W
A10R1250	322-3059-00	RES,FXD,FILM: 40.2 OHM,1%,0.2W
A10R1251	322-3059-00	RES,FXD,FILM: 40.2 OHM,1%,0.2W
A10R1260	313-1102-00	RES,FXD,FILM: 1K OHM,5%,0.2W
A10R1284	313-1820-00	RES,FXD,FILM: 82 OHM,5%,0.2W
A10R1285	313-1820-00	RES,FXD,FILM: 82 OHM,5%,0.2W
A10W204	131-0566-00	BUS,CONDUCTOR: DUMMY RES,0.094 OD X 0.225 L

DIAGRAM CHANGES

DIAGRAM  VERTICAL INPUTS

Change the value of resistor R131 (location 7A) to 62 Ω .

Change the value of resistor R151 (location 8A) to 62 Ω .

MANUAL CHANGE INFORMATION

Product: 2247A SERVICE

Date: 12-6-90

Change Reference: M72008

DESCRIPTION

Product Group 46

DIAGRAM CHANGES (cont)

DIAGRAM 2 VERTICAL PREAMPS & SWITCHING

This schematic has been replaced. See pullout page 13 of this insert. Following is a list of changes regarding Diagram 2.

Change the value of C275 to 120 pF.

Change the value of R211 to 2K Ω .

Change the value of R221 to 2K Ω .

Change the value of R231 to 2K Ω .

Change the value of R241 to 2K Ω .

Change the value of R261 to 47K Ω .

Change the value of R725 to 750 Ω .

Replace Resistor networks R250 and R251 with resistors:

[R1210, R1211, R1220, R1221, R1230, R1231, R1240, R1241 (100 Ω each)],

[R1250, R1251 (40.2 Ω each)],

[R1284, R1285(82 Ω each)]

Replace wire jumper W202 with resistor R206 (2.80K Ω).

Add capacitors C1250 and C1251 (2.2 pF each).

Add resistors R216 (10K Ω), R217 (4.7K Ω), and R249 (2.7 Ω).

Add wire jumper W204.

Connections to U201 and U202 have been changed.

DIAGRAM 3 A AND B TRIGGER SYSTEM

(See Insert Change Reference C6/0389 for the latest version of diagram 3.)

Change the value of resistor R460 (location 6K) to 680 Ω .

Add capacitor C488 (270 pF) from U431A pin 13 to circuit board ground. (See partial schematic below.)

Add capacitor C490 (430 pF) from U431A pin 14 to circuit board ground. (See partial schematic below.)

Add capacitor C496 (270 pF) from U431A pin 10 to circuit board ground. (See partial schematic below.)

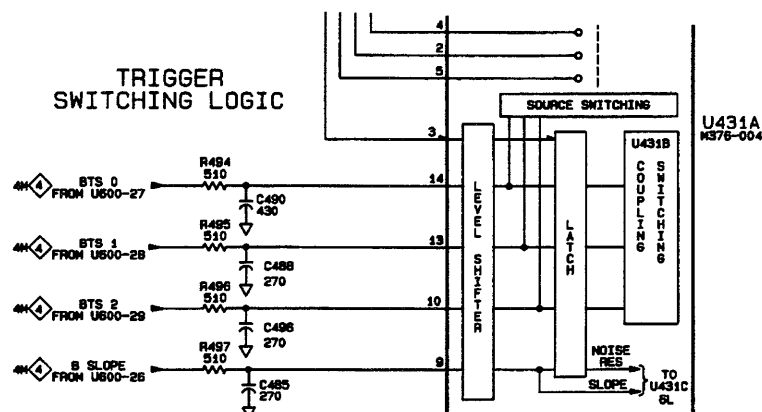

MANUAL CHANGE INFORMATION

Product: 2247A SERVICE Date: 12-6-90 Change Reference: M72008

DESCRIPTION

Product Group 46

DIAGRAM CHANGES (cont)

DIAGRAM 4 TRIGGER SELECT

Change the value of resistor R638 (location 8J) to 100K Ω .

Replace wire jumper W612 (location 8H) with diode CR612. (See partial schematic below.)

Add capacitor C636 (0.022 μ F) from R636 (location 8H) to circuit board ground. (See partial schematic below.)

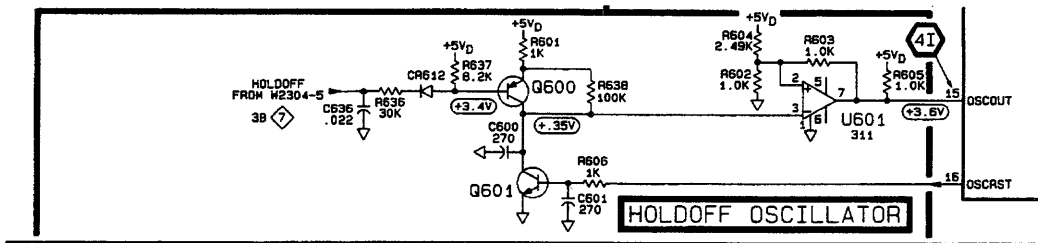
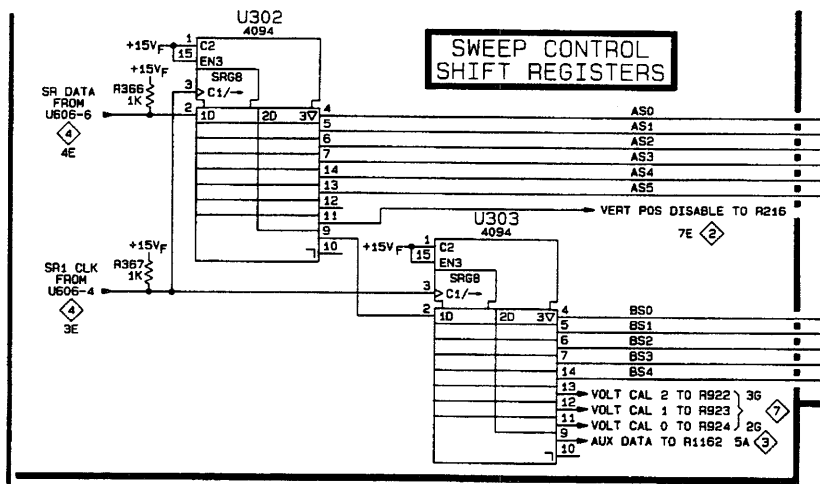

DIAGRAM 5 A AND B SWEEP & DELAY COMPARATORS

At grid location 2B, pin 11 of U302 is connected to resistor R216 Diagram 2. (See partial schematic below.)



MANUAL CHANGE INFORMATION

Product: 2247A SERVICE Date: 12-6-90 Change Reference: M72008

DESCRIPTION

Product Group 46

DIAGRAM CHANGES (cont)

DIAGRAM  HORIZONTAL OUTPUT AMPLIFIER

Remove jumpers W820 and W821 (location 5C). These are now circuit board runs.

DIAGRAM  Z-AXIS, CRT, PROBE ADJ,
& CONTROL MUX

This schematic has been replaced. See pullout page 15 of this insert. Following is a list of changes regarding Diagram 7.

Reconnect pin 4 of P2302.
Add resistor R925 (4.7K Ω).
Change the circuit connection of R2718.

DIAGRAM  MAIN BOARD POWER

Replace wire jumper W235 (location 7E) with resistor R1260 (1K Ω).

MANUAL CHANGE INFORMATION

Product: 2247A SERVICE

Date: 12-6-90

Change Reference: M72008

DESCRIPTION

Product Group 46

A10 - MAIN BOARD

ASSEMBLY A10

CIRCUIT NUMBER	SCHEM NUMBER	BOARD LOCATION	CIRCUIT NUMBER	SCHEM NUMBER	BOARD LOCATION	CIRCUIT NUMBER	SCHEM NUMBER	BOARD LOCATION	CIRCUIT NUMBER	SCHEM NUMBER	BOARD LOCATION
AT117	1	8B	C225	15	3D	C455	3	1G	C870	6	8J
AT127	1	4B	C228	2	10G	C462	3	1G	C880	6	8J
			C229	15	4D	C463	3	1F	C901	15	9B
C1	1	6C	C232	2	2E	C474	3	1F	C902	15	8A
C2	1	4C	C233	2	2E	C475	15	1F	C903	15	9A
C10	1	6B	C234	15	3D	C476	3	1E	C904	15	9B
C11	1	6B	C235	15	2D	C477	3	1F	C910	7	10B
C20	1	4B	C236	2	10G	C478	3	1E	C935	7	7B
C21	1	5B	C239	15	3D	C480	15	1J	C1001	7	7L
C101	1	6A	C242	2	1E	C481	15	3F	C1002	7	8M
C102	1	4A	C243	2	1E	C482	15	2F	C1003	7	8M
C103	1	3A	C244	15	2D	C483	3	2F	C1004	7	7L
C104	1	1A	C245	15	2D	C484	3	3G	C1005	15	7M
C105	1	6B	C248	2	11G	C485	3	2G	C1006	15	8L
C106	1	6A	C249	15	2D	C487	3	3F	C1101	15	3H
C107	1	5B	C258	2	4G	C488	3	2G	C1102	15	3G
C108	1	4A	C265	15	5F	C489	3	3G	C1103	3	4J
C111	1	10C	C268	2	9G	C491	2	2F	C1104	15	4H
C112	1	6A	C271	2	4F	C492	2	2F	C1105	3	5K
C113	1	5A	C272	2	4F	C493	2	2E	C1106	3	4G
C114	1	5C	C273	2	4F	C494	2	2F	C1107	3	4G
C121	1	10C	C274	2	4F	C496	3	2G	C1108	15	4G
C122	1	5A	C275	2	4F	C501	15	4M	C1110	3	3G
C123	1	4A	C282	15	4F	C502	15	4N	C1111	3	4H
C124	1	4C	C283	15	6F	C503	15	4N	C1114	3	4J
C125	1	1C	C287	15	6F	C505	15	9C	C1130	3	4G
C126	1	1D	C298	15	3F	C600	4	3N	C1143	3	4H
C131	1	10C	C301	5	8F	C601	4	3N	C1154	3	4G
C132	1	2A	C302	5	9F	C602	4	4L	C1155	3	4G
C133	1	2B	C303	5	8C	C603	4	3L	C1158	15	5L
C134	1	2B	C304	15	7D	C604	15	3M	C1159	15	5L
C135	15	2B	C305	5	9D	C605	15	2M	C1160	15	5K
C136	15	2B	C306	5	7C	C606	15	3L	C1250	2	5F
C137	1	2C	C307A	5	7E	C607	4	3L	C1251	2	5F
C138	1	2C	C307B	5	7E	C608	4	3M	C2701	15	7M
C139	2	2C	C307C	5	10F	C609	15	2J	C2702	15	6L
C140	15	2C	C308	5	7E	C610	15	2L	C2703	7	7M
C151	1	10C	C309	15	7H	C611	4	4K	C2704	7	7M
C152	1	2A	C310	5	7E	C612	4	3K	C2705	7	7N
C153	1	1B	C311	5	7F	C613	15	1N	C2706	7	6N
C154	1	1B	C312	5	9E	C614	4	5M	C2707	7	7M
C155	15	2B	C313	5	9E	C636	4	6N	C2708	7	7N
C156	15	1B	C314	5	7F	C666	4	4M	C2709	15	7M
C157	1	1C	C315	5	7G	C701	15	10J	C2710	7	7N
C158	1	1C	C316	15	8E	C702	15	9J	C2711	7	8M
C159	2	1C	C317	15	8E	C703	15	10K	C2712	7	8N
C171	15	2B	C318	15	9E	C704	15	9K	C2713	7	6N
C172	15	3C	C319	8	7F	C705	15	9H	C2715	7	10L
C173	1	3B	C320	15	8F	C706	2	10J	C2716	7	10L
C180	15	3D	C321	5	10F	C707	2	9J	C2717	7	11L
C181	15	6D	C322	15	9D	C708	15	9J	C2719	7	10M
C190	1	2C	C326	5	10E	C711	2	10J	C2720	7	8L
C191	1	1C	C329	5	10F	C712	2	10J	C2721	7	8K
C201	2	4G	C330	5	10G	C801	15	8K	C2723	7	7L
C202	2	4H	C337	15	10E	C802	6	7J	C2724	7	10M
C203	2	4H	C338	15	8G	C803	6	7K	C2759	7	7M
C204	2	5H	C339	15	9G	C804	6	8K	C2783	7	8N
C205	15	11H	C351	15	8C	C805	6	9H	C2784	7	6N
C206	15	10H	C421	3	3G	C806	15	8H	C2785	7	8N
C210	2	6E	C422	3	3G	C807	6	7J			
C211	2	5E	C423	3	3G	C808	6	9G	CR131	1	2B
C212	2	5E	C424	3	3G	C809	6	8K	CR151	1	1B
C213	2	5E	C425	3	2G	C811	2	7J	CR171	1	3B
C214	15	5E	C426	3	3H	C814	6	8J	CR201	2	5C
C215	15	5D	C432	3	2G	C815	15	7H	CR202	2	5C
C216	15	5G	C442	15	2H	C816	15	8H	CR260	2	4F
C217	15	5G	C444	3	2F	C817	6	6G	CR261	2	4F
C218	2	10G	C445	15	3F	C818	15	8J	CR301	5	7C
C219	15	5D	C447	3	2F	C819	6	7J	CR432	3	2G
C220	2	5D	C451	3	2G	C820	6	8J	CR462	3	1G
C221	2	4E	C452	3	2G	C821	15	8J	CR603	4	4M
C222	2	4E	C453	3	2G	C822	15	8J	CR612	4	6N
C223	2	4E	C454	3	2G	C860	6	7J	CR801	6	5M
C224	15	3D									

MANUAL CHANGE INFORMATION

 Product: 2247A SERVICE

 Date: 12-6-90

 Change Reference: M72008

DESCRIPTION

 Product Group **46**

A10 - MAIN BOARD (cont)

ASSEMBLY A10

CIRCUIT NUMBER	SCHEM NUMBER	BOARD LOCATION	CIRCUIT NUMBER	SCHEM NUMBER	BOARD LOCATION	CIRCUIT NUMBER	SCHEM NUMBER	BOARD LOCATION	CIRCUIT NUMBER	SCHEM NUMBER	BOARD LOCATION
CR802	6	4M	P8	7	10N	Q802	6	7K	R155	1	1B
CR803	6	8J	P9	7	8N	Q803	6	7J	R156	1	1C
CR807	6	8J	P9	7	9N	Q804	6	7J	R157	1	1C
CR935	7	7A	P17	6	7K	Q805	6	8K	R158	2	1C
CR936	7	7A	P18	6	8K	Q806	6	8K	R159	1	1C
CR1001	7	5L	P19	2	10H	Q807	6	8J	R160	2	1C
CR1002	7	5L	P20	2	9H	Q809	6	8H	R161	1	1B
CR1003	7	8L	P2302	15	10D	Q810	6	7H	R162	1	1B
CR1004	7	7L	P2302	7	10D	Q811	6	7J	R171	1	3B
CR1005	7	3L	P2304	7	11D	Q812	6	8J	R175	1	3B
CR2701	7	9M	P2502	15	1L	Q905	7	10A	R176	1	3C
CR2702	7	9M	P2502	4	1L	Q907	7	10A	R177	1	3C
CR2703	7	8N			2B	Q908	7	10A	R178	1	3C
CR2704	7	6N	Q131A	1	2B	Q1001	7	4L	R179	1	3C
CR2705	7	8M	Q131B	1	2B	Q1002	7	4L	R180	1	2B
CR2707	7	7L	Q151A	1	1B	Q1003	7	4L	R181	1	1B
CR2713	7	10L	Q151B	1	1B	Q1004	7	4L	R182	15	6D
CR2714	7	11L	Q171	1	2B	Q1005	7	7L	R201	2	5G
CR2715	7	9L	Q250	2	4E	Q1101	3	5J	R202	2	5G
CR2716	7	9M	Q251	2	4F	Q1102	3	5J	R203	2	5G
CR2717	7	9M	Q252	2	4E	Q1103	3	5J	R204	2	5G
CR2718	7	8L	Q253	2	4F	Q1104	3	5J	R205	2	6H
			Q284	2	6E	Q1105	3	5J	R206	2	5G
DL21	2	3F	Q285	2	5E	Q1106	3	5J	R207	2	9G
DL21	2	10K	Q301	5	7C	Q2701	7	7N	R208	15	11H
DL22	3	2H	Q302	5	6E	Q2702	7	7M	R209	2	1M
DL22	3	3K	Q303	5	8F	Q2703	7	7N	R210	2	6E
			Q304	5	8F	Q2704	7	6N	R211	2	6E
DS901	7	8B	Q305	5	7E	Q2705	7	7M	R212	2	2L
DS902	7	9B	Q306	5	7E	Q2706	7	7M	R213	2	2M
DS903	7	11B	Q307	5	8D	Q2707	7	6M	R214	2	6H
DS2701	7	9N	Q308	5	8F	Q2708	7	6L	R215	2	6N
DS2702	7	9M	Q309	5	8F	Q2709	7	6L	R216	2	8G
DS2703	7	9M	Q310A	5	8E	Q2711	7	10L	R217	2	7G
DS2704	7	9M	Q310B	5	8E	Q2712	7	10L	R218	2	5E
			Q311	5	8F	Q2713	7	11L	R219	2	5C
			Q312	5	8E	Q2715	7	6M	R220	2	4E
J11	1	6A	Q313	5	9F				R221	2	4E
J12	1	5A	Q315	5	9E	R12	1	6C	R222	2	2L
J13	1	3A	Q316	5	9F	R13	1	6C	R223	2	2M
J14	1	1A	Q317	5	9F	R22	1	5C	R224	2	6H
J15	7	7A	Q318	5	10E	R23	1	4C	R225	2	8C
J927	7	11B	Q320	5	9E	R101	1	7A	R226	15	6E
J1204	15	5J	Q321	5	9F	R102	1	7A	R227	2	8C
			Q322	5	9F	R103	1	7A	R228	2	4E
K100	1	6A	Q323A	5	9E	R104	1	7A	R229	2	5D
K101	1	5A	Q323B	5	9E	R105	1	7A	R230	2	3E
K102	1	5B	Q325	5	10E	R106	1	7B	R231	2	3E
K103	1	7B	Q326	5	8F	R107	1	7B	R232	2	1L
K104	1	5D	Q328	5	8E	R108	1	7B	R233	2	2M
K105	1	6D	Q329	5	9E	R111	1	6A	R234	2	6H
K107	1	4A	Q330	5	8F	R113	1	5A	R235	2	3E
K108	1	4A	Q331	5	9F	R114	1	5A	R236	2	2D
K109	1	4B	Q332	5	9F	R115	2	5D	R240	2	2E
K110	1	5B	Q333	5	8F	R121	1	5A	R241	2	2E
K111	1	4D	Q440	3	2H	R123	1	4A	R242	2	1L
K112	1	4D	Q444	3	3F	R124	1	3A	R243	2	2M
L101	15	2C	Q470	3	1H	R125	2	4D	R244	2	6H
L102	15	2C	Q474	3	2F	R131	1	2A	R245	15	3D
L130	1	2C	Q480	3	1F	R132	1	2A	R248	2	2E
L140	1	1C	Q600	4	3N	R133	1	2A	R249	2	5G
L201	15	6E	Q601	4	3N	R134	1	2A	R254	2	5F
L216	15	4H	Q602	4	2K	R135	1	2B	R255	2	5F
L217	15	5H	Q603	4	2K	R136	1	2C	R256	2	6F
L473	3	3H	Q604	4	3K	R137	1	2C	R260	2	5E
L474	3	2G	Q605	4	3K	R138	2	2C	R261	2	5E
L445	15	3J	Q606	4	2K	R139	1	2C	R262	2	5F
L462	3	1G	Q607	4	2K	R140	2	2C	R263	2	5F
L475	15	1J	Q608	4	2L	R141	1	2B	R264	2	5F
L701	2	9J	Q701	2	9J	R142	1	2B	R265	2	5F
L702	2	10J	Q702	2	10J	R151	1	2A	R266	2	4F
L703	2	9H	Q703	2	9K	R152	1	2A	R267	2	4F
L704	2	10H	Q704	2	11H	R153	1	1A	R268	2	5F
			Q801	6	7K	R154	1	2A	R269	2	5F

MANUAL CHANGE INFORMATION

Product: 2247A SERVICE

Date: 12-6-90

Change Reference: M72008

DESCRIPTION

Product Group 46

A10 - MAIN BOARD (cont)

ASSEMBLY A10

CIRCUIT NUMBER	SCHEM NUMBER	BOARD LOCATION	CIRCUIT NUMBER	SCHEM NUMBER	BOARD LOCATION	CIRCUIT NUMBER	SCHEM NUMBER	BOARD LOCATION	CIRCUIT NUMBER	SCHEM NUMBER	BOARD LOCATION
R270	2	4F	R348	5	8H	R448	3	2F	R628	4	2K
R271	2	4F	R349	5	7H	R449	3	3F	R630	4	2N
R272	2	4F	R350	5	7H	R450	3	1H	R631	4	3L
R273	2	4G	R352	5	7H	R451	3	1G	R636	4	6N
R274	2	3E	R353	5	9D	R452	3	1G	R637	4	3N
R275	2	4F	R354	5	9E	R453	3	2G	R638	4	3N
R276	2	4F	R355	5	9E	R454	3	2G	R639	4	3L
R277	2	4F	R356	5	9F	R455	3	2H	R640	4	3L
R278	2	3F	R357	5	8F	R456	3	1G	R641	4	4M
R279	2	3F	R358	6	9D	R460	3	1G	R642	4	4M
R280	2	3F	R359	5	8F	R461	3	1G	R643	4	3M
R281	2	3F	R360	5	9F	R462	3	1G	R644	4	3M
R282	15	4F	R361	5	8G	R463	3	1F	R645	4	3M
R283	15	6G	R362	5	8F	R470	3	1G	R646	4	3M
R284	2	6F	R363	5	9F	R471	3	1H	R647	4	1J
R285	2	6E	R364	5	9G	R472	3	1H	R648	4	3K
R286	2	5G	R365	5	10E	R473	3	1H	R649	4	3K
R287	2	5F	R366	5	8C	R474	3	1H	R650	4	3M
R288	2	6F	R367	5	9C	R475	3	1F	R651	4	4M
R289	2	5F	R369	6	8D	R476	3	1F	R652	4	4M
R290	2	6F	R370	5	9G	R477	3	1F	R653	4	3K
R291	2	5F	R371	5	9G	R478	3	1F	R654	4	3L
R292	2	5F	R372	5	9G	R479	3	1F	R655	4	3L
R293	2	5F	R373	5	10G	R480	15	4F	R656	4	4K
R294	2	5G	R374	15	10E	R481	15	1J	R657	4	4K
R295	2	5G	R375	5	10E	R483	3	3F	R658	4	4K
R296	2	6F	R376	5	10E	R484	3	1E	R659	4	4M
R297	15	6F	R377	5	8H	R485	3	1E	R662	4	2L
R298	15	3F	R378	5	6J	R486	3	1E	R663	4	3K
R301	5	9E	R379	5	7G	R487	3	1E	R664	4	3K
R302	5	7E	R380	5	6J	R490	3	3J	R665	4	4M
R303	5	8F	R381	5	10F	R491	3	3J	R666	4	4K
R304	5	8F	R382	5	7G	R492	3	3J	R669	4	3L
R305	5	8G	R383	5	9G	R493	3	2J	R670	4	4K
R306	5	7C	R384	5	8D	R494	3	2J	R671	4	3M
R307	5	7C	R385	5	9F	R495	3	2J	R672	4	3M
R308	5	7C	R386	5	9F	R496	3	2J	R673	4	4M
R309	5	9C	R387	5	8F	R497	3	2J	R674	4	4M
R310	5	7C	R388	5	8F	R498	3	3J	R701	15	9J
R311	5	8C	R390	15	8F	R501	4	1L	R702	2	9J
R312	15	7D	R392	15	7C	R502	4	5N	R703	2	11J
R313	5	7D	R393	5	10F	R503	7	10C	R706	2	9K
R314	5	7C	R394	5	10F	R504	15	9C	R707	2	10K
R315	5	10E	R395	5	8E	R505	7	9C	R708	2	10H
R316	5	7F	R396	5	10E	R506	7	9C	R709	15	9J
R317	5	8E	R401	3	3F	R507	7	9C	R710	2	10K
R318	5	8E	R402	3	3F	R508	7	10C	R711	2	10J
R319	5	8F	R403	3	3J	R510	7	10C	R712	2	10J
R320	5	8E	R410	3	3G	R512	7	10C	R715	2	10K
R321	5	8D	R411	3	3G	R601	4	3N	R716	2	10K
R322	5	7H	R412	3	3G	R602	4	2N	R717	2	9K
R323	5	7G	R413	3	3G	R603	4	1N	R718	2	9K
R325	5	7D	R414	3	3H	R604	4	1N	R719	2	10H
R326	5	7D	R415	3	2G	R605	4	1N	R720	2	10H
R327	5	9F	R416	3	2G	R606	4	3N	R721	2	9K
R328	5	8E	R417	3	2H	R609	4	2K	R722	2	9K
R329	5	9E	R420	3	3H	R610	4	2K	R723	15	9J
R330	5	9E	R421	3	3G	R611	4	3K	R724	2	9K
R331	5	8E	R422	3	3G	R612	4	3M	R725	2	9K
R332	5	7G	R423	3	3G	R613	4	2K	R726	2	11J
R333	5	8G	R424	3	3G	R614	4	3L	R727	2	10K
R334	5	8G	R425	3	3G	R615	4	4L	R728	2	10H
R335	5	9F	R426	3	3H	R616	4	3K	R729	2	10H
R336	5	9F	R430	3	2G	R617	4	3K	R730	2	9K
R337	5	8E	R431	3	2F	R618	4	3M	R731	2	9H
R338	5	9E	R432	3	2G	R619	4	3M	R732	2	10H
R339	15	9E	R440	3	2G	R620	4	4M	R733	15	10K
R340	5	7G	R441	3	3H	R621	4	4L	R734	15	10H
R341	5	9F	R442	3	3H	R622	4	3K	R801	6	8K
R342	5	9E	R443	3	2H	R623	4	3K	R802	6	7K
R343	5	9F	R444	3	3H	R624	4	2L	R803	6	8K
R344	5	8E	R445	3	2F	R625	4	2L	R804	6	8K
R345	15	8E	R446	3	3F	R626	4	4L	R805	6	8J
R346	5	8E	R447	3	2F	R627	4	3L	R806	6	7J

MANUAL CHANGE INFORMATION

Product: 2247A SERVICE

Date: 12-6-90

Change Reference: M72008

DESCRIPTION

Product Group 46

A10 - MAIN BOARD (cont)

ASSEMBLY A10

CIRCUIT NUMBER	SCHEM NUMBER	BOARD LOCATION	CIRCUIT NUMBER	SCHEM NUMBER	BOARD LOCATION	CIRCUIT NUMBER	SCHEM NUMBER	BOARD LOCATION	CIRCUIT NUMBER	SCHEM NUMBER	BOARD LOCATION
R807	6	9G	R1010	7	7L	R2711	7	7N	U280	2	5F
R808	6	7H	R1020	7	7L	R2712	7	7M	U301	5	9D
R809	6	8H	R1021	7	7L	R2713	7	7M	U301	6	9D
R810	6	8H	R1022	7	7L	R2714	7	7M	U302	5	8C
R811	6	7J	R1023	7	7L	R2715	7	7M	U302	15	8C
R812	6	8H	R1024	7	7L	R2716	7	7M	U303	5	9C
R813	6	8J	R1025	7	8L	R2717	7	7M	U303	15	9C
R814	6	8J	R1026	15	8M	R2718	7	7M	U304	5	8D
R820	6	8J	R1027	15	8L	R2719	7	8N	U304	15	8D
R821	6	7J	R1028	7	4L	R2720	7	8N	U307	5	7D
R822	6	7K	R1103	3	4G	R2721	7	9N	U307	15	7D
R823	6	8G	R1104	3	4G	R2722	7	6L	U308	5	7D
R825	6	8H	R1105	3	6K	R2723	7	9M	U308	15	7D
R826	6	8G	R1106	3	6K	R2724	7	9M	U309	5	7C
R827	6	9H	R1108	15	4G	R2726	7	6L	U309	15	7C
R828	6	7J	R1110	3	4K	R2727	7	7L	U310	5	10D
R829	6	7K	R1111	3	5K	R2728	7	6L	U310	15	10D
R830	6	8K	R1112	3	4K	R2729	7	7L	U311	5	10D
R831	6	8J	R1113	3	5K	R2733	7	9K	U311	15	10D
R836	6	9H	R1114	3	5K	R2734	7	10L	U313	5	8E
R837	15	9K	R1115	3	4J	R2735	7	10K	U315	5	8F
R854	6	8H	R1116	3	4J	R2736	7	10L	U315	15	8F
R855	6	7H	R1117	3	3J	R2737	7	10K	U316	5	7H
R856	6	8H	R1118	3	4J	R2738	7	11L	U316	15	7H
R857	6	8H	R1120	3	5K	R2739	7	11L	U421	3	3F
R860	6	8H	R1121	3	5K	R2740	7	11L	U421	15	3F
R861	6	8J	R1122	3	5K	R2741	7	8M	U431	3	2F
R862	6	7J	R1123	3	5K	R2742	7	8L	U431	15	2F
R863	6	7J	R1124	3	5K	R2743	7	8L	U441	3	1H
R871	6	8J	R1125	3	5J	R2745	7	7N	U441	15	1H
R872	6	8J	R1126	3	5J	R2750	7	8M	U442	3	3H
R873	6	8J	R1127	3	4J	R2751	7	9M	U442	15	3H
R891	6	8K	R1128	3	5J	R2758	7	9L	U501	4	5M
R892	6	8K	R1131	3	4G	R2760	7	10M	U501	15	5M
R893	6	8J	R1132	3	4G	R2765	7	7M	U502	4	4N
R894	6	8J	R1133	3	4H	R2763	15	7N	U502	15	4N
R896	6	8J	R1134	3	4H	R2764	7	7N	U503	4	5N
R897	6	8K	R1135	3	4H	R2765	7	8N	U503	15	5N
R898	6	7K	R1136	3	4H	R2766	7	6N	U506	7	10C
R906	7	10B	R1142	3	4H	R2767	7	6N	U506	15	10C
R907	7	10A	R1143	3	4H	R2768	7	7N	U600	4	2M
R908	7	10A	R1144	3	4H	R2769	7	8N	U600	15	2M
R909	7	8B	R1145	3	4H	R2795	7	7L	U601	4	1N
R910	7	10B	R1150	3	3G	R2796	7	6M	U601	15	1N
R911	7	8A	R1154	3	4G				U602	4	4K
R915	15	9A	R1155	3	4G				U602	15	4K
RL 16	15	9A	R1158	15	4L	U112	1	6C	U603	4	2K
R920	7	8B	R1159	15	5J	U112	15	6C	U603	15	2K
R921	7	8B	R1160	15	5J	U122	1	4C	U604	4	2L
R922	7	9C	R1162	3	6K	U122	15	4C	U604	15	2L
R923	7	9C	R1163	3	5K	U171	1	3B	U606	4	3M
R924	7	9C	R1170	3	4J	U171	15	3B	U606	15	3M
R925	7	9B	R1210	2	5E	U172	1	3B	U701	2	10J
R930	7	8B	R1211	2	5E	U172	15	3B	U701	15	10J
R931	7	7A	R1220	2	4E	U173	1	3C	U702	2	9K
R932	7	7B	R1221	2	4E	U173	15	3C	U702	15	9K
R933	7	7B	R1230	2	3E	U174	1	3A	U801	2	7H
R934	7	7B	R1231	2	3E	U175	1	3C	U801	2	7H
R935	7	7B	R1240	2	2E	U201	2	5H	U801	15	7H
R936	7	7A	R1241	2	2E	U201	15	5H	U802	6	8H
R937	7	7A	R1250	2	5F	U202	2	5G	U802	15	8H
R938	7	7B	R1251	2	5F	U202	15	5G	U901	15	9A
R939	7	7B	R1260	15	5D	U203	2	10G	U930	7	8B
R940	7	7A	R1284	2	5E	U203	15	10G	U930	15	8B
R941	7	8A	R1285	2	5E	U210	2	5E	U931	7	9B
R1001	7	4L	R2701	7	6L	U210	15	5E	U931	15	9B
R1002	7	5M	R2702	7	6L	U220	2	4E	U932	15	8A
R1003	7	4M	R2703	7	7M	U220	15	4E	U1001	7	7L
R1004	7	4L	R2704	7	7L	U230	2	3E	U1001	15	7L
R1005	7	8L	R2705	7	7L	U230	15	3E	U1101	3	4G
R1006	7	7L	R2706	7	7M	U240	2	2E	U1101	7	4G
R1007	7	8L	R2708	7	7M	U240	15	2E	U1101	15	4G
R1008	7	8L	R2709	7	7M	U260	2	5F	U1101	3	4G
R1009	7	7L	R2710	7	6M	U260	15	5F	U1102	3	4G

MANUAL CHANGE INFORMATION

Product: 2247A SERVICE Date: 12-6-90 Change Reference: M72008

DESCRIPTION

Product Group 46

A10—MAIN BOARD (cont)

ASSEMBLY A10

CIRCUIT NUMBER	SCHEM NUMBER	BOARD LOCATION	CIRCUIT NUMBER	SCHEM NUMBER	BOARD LOCATION	CIRCUIT NUMBER	SCHEM NUMBER	BOARD LOCATION	CIRCUIT NUMBER	SCHEM NUMBER	BOARD LOCATION
U1102	15	4G	W100	1	5C	W505	4	3N	W1203	15	1J
U1103	3	5K	W101	1	5C	W506	4	3N	W1204	15	7G
U1103	15	5K	W102	1	3B	W507	4	5N	W1205	15	2J
U1104	3	4H	W103	15	3C	W510	4	6M	W1209	15	4J
U1104	15	4H	W200	2	6G	W603	4	4M	W1210	15	2J
U1106	3	5L	W201	2	6G	W604	4	4L	W1216	15	9C
U1106	15	5L	W203	2	6H	W605	4	6L	W1217	15	6H
			W204	2	6H	W606	15	2K	W1218	15	6H
VR301	5	7F	W205	2	6G	W607	15	5M	W1221	15	2J
VR302	5	6F	W206	2	6G	W610	4	3N	W1222	15	6D
VR303	5	9G	W207	2	6G	W611	4	3N	W1223	15	7D
VR304	5	9G	W208	2	6G	W802	5	8G	W1231	15	8K
VR308	5	9F	W209	2	6G	W805	6	6M	W1237	15	7K
VR309	5	7G	W210	2	10G	W806	6	7K	W1247	15	7D
VR310	5	9G	W223	2	5D	W807	6	6M	W1248	15	6H
VR311	5	8E	W231	2	2E	W808	6	7K	W1249	15	6H
VR312	5	10E	W232	2	2E	W810	6	6H	W1250	15	8K
VR801	6	8J	W304	5	8G	W811	6	5H	W1251	15	6H
VR2701	7	6M	W305	6	10E	W815	2	8G	W1252	15	6H
			W401	3	4H	W900	7	9B	W1255	15	6F
W9	7	8N	W406	3	3H	W1000	7	4L	W1277	15	8K
W9	7	10M	W413	3	3J	W1101	3	6K	W1288	7	6J
W11	1	6A	W414	3	3J	W1102	3	3J	W2302	7	10D
W12	1	5A	W415A	2	5E	W1103	3	6K	W2302	15	10D
W13	1	3A	W415B	2	3F	W1104	15	3J	W2304	7	11D
W14	1	2A	W416A	2	3E	W1105	15	4J	W2502	4	1L
W16	7	7K	W416B	2	3E	W1106	3	6L	W2502	15	1L
W17	6	7K	W501	15	1M	W1108	3	5L	W2701	7	6M
W18	6	8K	W502	4	3M	W1200	15	6F			
W19	2	10H	W503	4	3M	W1201	15	9C			
W20	2	9H	W504	4	3M	W1202	15	9H			
									Y800	4	3L

A B C D E F G H J K L M N

1
2
3
4
5
6
7
8
9
10

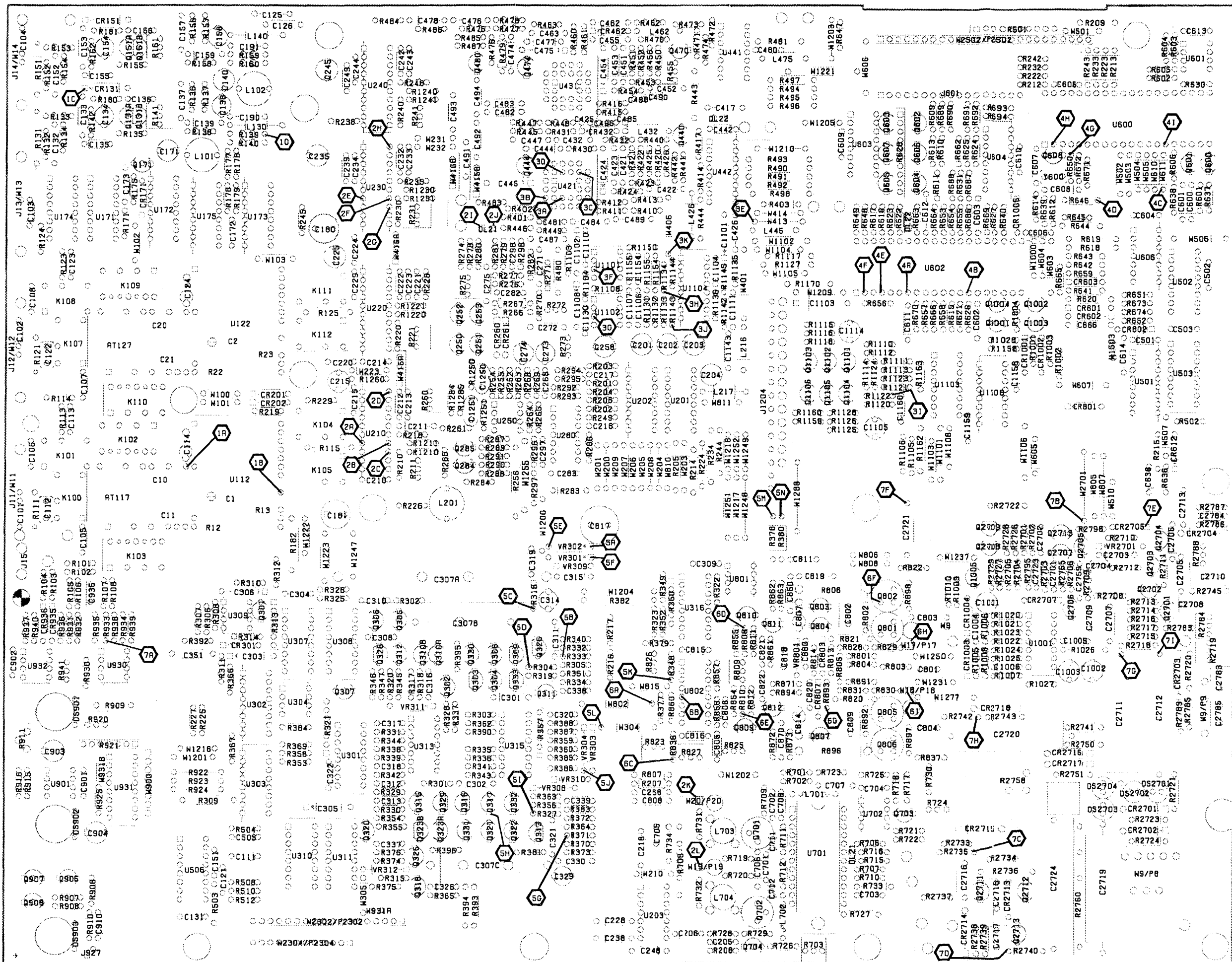

MANUAL CHANGE INFORMATION

Product: 2247A SERVICE Date: 12-6-90 Change Reference: M72008

DESCRIPTION

Product Group 46

VERTICAL PREAMPS & OUTPUT AMPLIFIER DIAGRAM 2

ASSEMBLY A10

CIRCUIT NUMBER	SCHEM LOCATION	BOARD LOCATION	CIRCUIT NUMBER	SCHEM LOCATION	BOARD LOCATION	CIRCUIT NUMBER	SCHEM LOCATION	BOARD LOCATION	CIRCUIT NUMBER	SCHEM LOCATION	BOARD LOCATION
C139	4C	2C	Q251	4G	4F	R254	3G	5F	R726	6K	11J
C159	5C	1C	Q252	3J	4E	R255	3G	5F	R727	5K	10K
C201	7C	4G	Q253	4J	4F	R256	2G	6F	R728	5K	10H
C202	7C	4H	Q284	6F	6E	R260	7G	5E	R729	5K	10H
C203	7C	4H	Q285	6F	5E	R261	7G	5E	R730	5K	9K
C204	8C	5H	Q701	3M	9J	R262	3F	5F	R731	3M	9H
C210	1C	6E	Q702	4M	10J	R263	4F	5F	R732	4M	10H
C211	2D	5E	Q703	2M	9K	R264	3F	5F	R1210	1E	5E
C212	1E	5E	Q704	6K	11H	R265	4F	5F	R1211	1E	5E
C213	2E	5E				R266	2G	4F	R1220	2E	4E
C218	6B	10G	R115	1D	5D	R267	2G	4F	R1221	2E	4E
C220	3C	5D	R125	2D	4D	R268	4J	5F	R1230	4E	3E
C221	3D	4E	R138	4C	2C	R269	2J	5F	R1231	4E	3E
C222	3E	4E	R140	4D	2C	R270	3J	4F	R1240	5E	2E
C223	3E	4E	R158	5C	1C	R271	4H	4F	R1241	5E	2E
C228	7B	10G	R160	5D	1C	R272	3H	4F	R1250	3H	5F
C232	4E	2E	R201	6E	5G	R273	3H	4G	R1251	4H	5F
C233	5E	2E	R202	7E	5G	R274	3J	3E	R1284	5F	5E
C238	7B	10G	R203	8E	5G	R275	3G	4F	R1285	5F	5E
C242	5E	1E	R204	8E	5G	R276	4G	4F			
C243	6E	1E	R205	7D	6H	R277	3G	4F	U201	8D	5H
C248	8B	11G	R206	7E	5G	R278	3J	3F	U202	7D	5G
C258	8C	4G	R207	7C	9G	R279	4J	3F	U203A	6B	10G
C268	7D	9G	R209	7C	1M	R280	3J	3F	U203B	7B	10G
C271	3H	4F	R210	1E	6E	R281	4J	3F	U203C	8B	10G
C272	3H	4F	R211	1E	6E	R284	6E	6F	U203D	8B	10G
C273	3H	4F	R212	2C	2L	R285	6G	6E	U210	1D	5E
C274	3H	4F	R213	2C	2M	R286	7F	5G	U220	2D	4E
C275	4G	4F	R214	2C	6H	R287	7F	5F	U230	3D	3E
C491	2E	2F	R215	7C	6N	R288	7G	6F	U240	5D	2E
C492	3E	2F	R216	7C	8G	R289	6G	5F	U260	2F	5F
C493	4E	2E	R217	7C	7G	R290	7F	6F	U280	8F	5F
C494	6E	2F	R218	2C	5E	R291	7F	5F	U701	2L	10J
C706	3L	10J	R219	1C	5C	R292	8E	5F	U702	1M	9K
C707	6L	9J	R220	2E	4E	R293	8F	5F	U801B	8B	7H
C711	3L	10J	R221	2E	4E	R294	8G	5G			
C712	4L	10J	R222	3C	2L	R295	8G	5G	W19	4M	10H
C811	8B	7J	R223	3C	2M	R296	7F	6F	W20	3M	9H
C1250	2H	5F	R224	3C	6H	R702	5K	9J	W200	3C	6G
C1251	4H	5F	R225	1C	8C	R703	5K	11J	W201	2C	6G
			R227	2C	8C	R706	3K	9K	W203	7D	6H
CR201	2C	5C	R228	3C	4E	R707	4K	10K	W204	7D	6H
CR202	1C	5C	R229	1C	5D	R708	3M	10H	W205	7B	6G
CR260	3J	4F	R230	4E	3E	R710	1L	10K	W206	6B	6G
CR261	4J	4F	R231	4E	3E	R711	3L	10J	W207	7B	6G
			R232	5C	1L	R712	4L	10J	W208	8B	6G
DL21	3K	3F	R233	5C	2M	R715	1L	10K	W209	8C	6G
			R234	4C	6H	R716	2L	10K	W210	8B	10G
L701	5L	9J	R235	5D	3E	R717	2M	9K	W223	3C	5D
L702	6L	10J	R238	5C	2D	R718	1M	9K	W231	4E	2E
L703	3M	9H	R240	5E	2E	R719	3M	10H	W232	4E	2E
L704	4M	10H	R241	5E	2E	R720	4M	10H	W415A	1E	5E
			R242	6C	1L	R721	1L	9K	W415B	1E	3F
P19	4N	10H	R243	6C	2M	R722	2L	9K	W416A	3E	3E
P20	3N	9H	R244	6C	6H	R724	4K	9K	W416B	3E	3E
			R248	6D	2E	R725	4K	9K	W815	8B	8G
Q250	3G	4E	R249	8E	5G						

Partial A10 also shown on diagrams 1, 3, 4, 5, 6, 7 and 15.

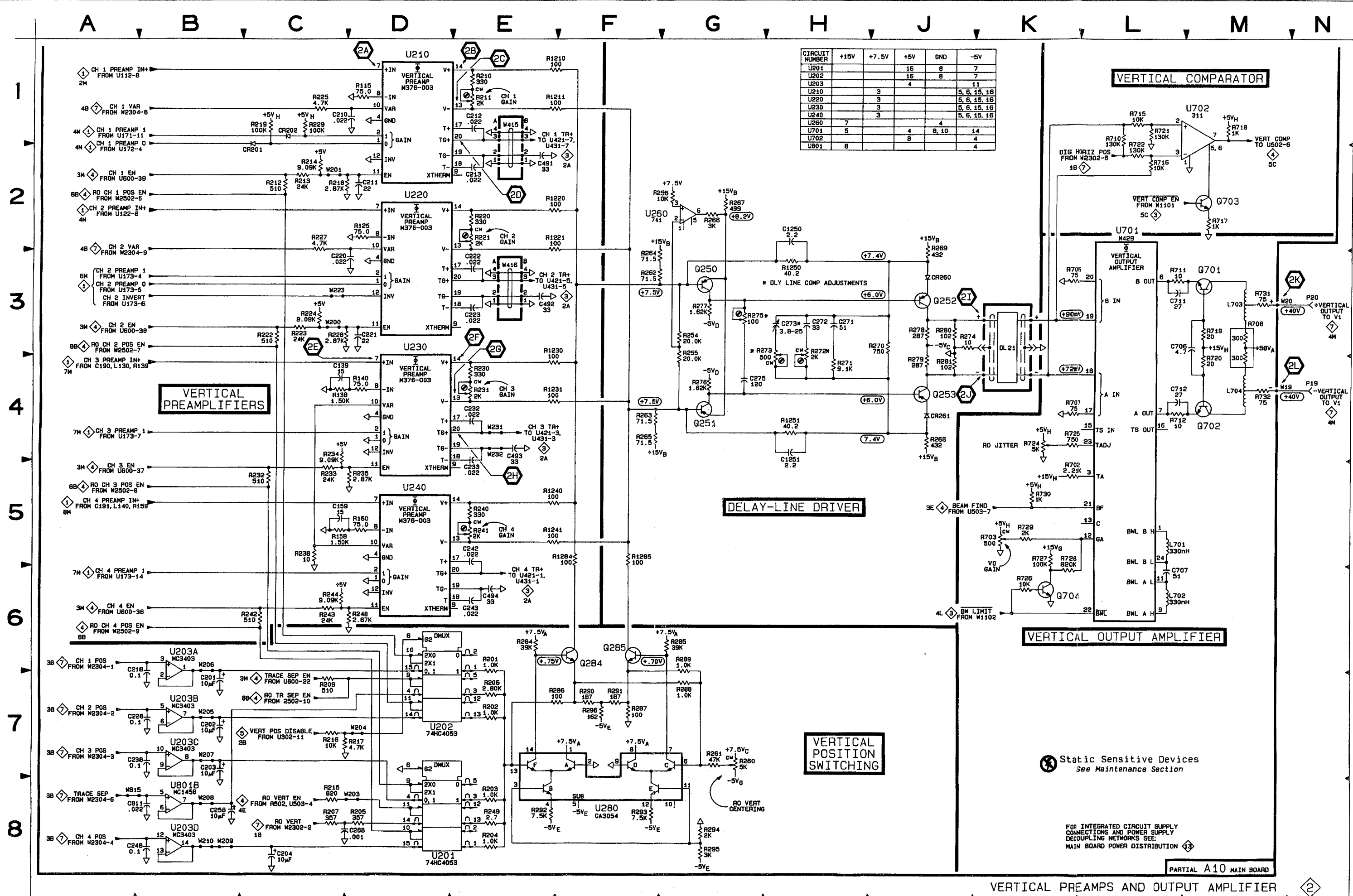

CIRCUIT NUMBER	+15V	+7.5V	+5V	GND	-5V
U201			16	8	7
U202			16	8	7
U203			4		11
U210		3			5, 6, 15, 16
U220		3			5, 6, 15, 16
U230		3			5, 6, 15, 16
U240		3			5, 6, 15, 16
U260	7			4	
U701	5		4	8, 10	14
U702			8		4
U801	8				

VERTICAL PREAMPLIFIERS

DELAY-LINE DRIVER

VERTICAL COMPARATOR

VERTICAL OUTPUT AMPLIFIER

VERTICAL POSITION SWITCHING

Static Sensitive Devices
See Maintenance Section

FOR INTEGRATED CIRCUIT SUPPLY
CONNECTIONS AND POWER SUPPLY
DECOUPLING NETWORKS SEE
MAIN BOARD POWER DISTRIBUTION

PARTIAL A10 MAIN BOARD

VERTICAL PREAMPS AND OUTPUT AMPLIFIER

MANUAL CHANGE INFORMATION

Product: 2247A SERVICE Date: 12-6-90 Change Reference: M72008

DESCRIPTION

Product Group 46

Z-AXIS, CRT, PROBE ADJUST and CONTROL MUX DIAGRAM 7

ASSEMBLY A8

CIRCUIT NUMBER	SCHEM LOCATION	BOARD LOCATION	CIRCUIT NUMBER	SCHEM LOCATION	BOARD LOCATION	CIRCUIT NUMBER	SCHEM LOCATION	BOARD LOCATION	CIRCUIT NUMBER	SCHEM LOCATION	BOARD LOCATION
R901	5A	1A	R902	6A	1C	R903	6A	1F	R905	4A	1H

Partial A10 also shown on diagram 15.

ASSEMBLY A10

C910	2L	10B	DS2701	8L	9N	R930	1H	8B	R2726	5E	6L
C935	2H	7B	DS2702	7L	9M	R931	1H	7A	R2727	5E	7L
C1001	5C	7L	DS2703	5K	9M	R932	1H	7B	R2728	5E	6L
C1002	6C	8M	DS2704	6K	9M	R933	1H	7B	R2729	6E	7L
C1003	6C	8M				R934	2G	7B	R2733	6F	9K
C1004	7C	7L	J15	2K	7A	R935	2H	7B	R2734	6F	10L
C2703	7G	7M	J927	2L	11B	R936	1J	7A	R2735	5G	10K
C2704	6G	7M				R937	2J	7A	R2736	5G	10L
C2705	7G	7N	P8	8A	10N	R938	1G	7B	R2737	5G	10K
C2706	7H	6N	P9	3M	8N	R939	2G	7B	R2738	5G	11L
C2707	7H	7M	P9	4M	9N	R940	2J	7A	R2739	4H	11L
C2708	6H	7N	P2302	1A	10D	R941	1H	8A	R2740	5J	11L
C2710	7J	7N	P2304	3A	10D	R1001	5C	4L	R2741	5J	8M
C2711	7K	8M				R1002	6C	5M	R2742	6J	8L
C2712	7K	8N	Q905	4E	10A	R1003	6C	4M	R2743	6H	8L
C2713	8K	6N	Q907	4E	10A	R1004	7C	4L	R2745	7J	7N
C2715	6G	10L	Q908	4F	10A	R1005	5C	8L	R2750	6J	8M
C2716	5H	10L	Q1001	5D	4L	R1006	6D	7L	R2751	6K	9M
C2717	5H	11L	Q1002	6D	4L	R1007	7D	8L	R2756	6L	9L
C2719	5J	10M	Q1003	6D	4L	R1008	7D	8L	R2760	6L	10M
C2720	6J	8L	Q1004	7D	4L	R1009	8C	7L	R2765	7F	7M
C2721	6J	6K	Q1005	8D	7L	R1010	8B	7L	R2784	3L	7N
C2723	6E	7L	Q2701	7H	7N	R1020	5B	7L	R2785	3L	8N
C2724	8K	10M	Q2702	7H	7M	R1021	5B	7L	R2786	4L	6N
C2759	7F	7M	Q2703	7H	7N	R1022	6B	7L	R2787	5L	6N
C2783	3L	8N	Q2704	8H	6N	R1023	6B	7L	R2788	5L	7N
C2784	5L	6N	Q2705	7G	7M	R1024	7B	7L	R2789	5L	8N
C2785	5L	8N	Q2706	8F	7M	R1025	7B	8L	R2795	7E	7L
			Q2707	7F	6M	R1028	5D	4L	R2796	6F	6M
			Q2708	5E	6L	R2701	7E	6L			
CR935	2J	7A	Q2709	5F	6L	R2702	7E	6L			
CR936	2J	7A	Q2711	5G	10L	R2703	6E	7M	U506	2E	10C
CR1001	5D	5L	Q2712	5H	10L	R2704	6E	7L	U930A	1H	8B
CR1002	7D	5L	Q2713	5H	11L	R2705	7F	7L	U930B	2H	8B
CR1003	8C	8L	Q2715	7F	6M	R2706	7F	7M	U931	3H	9B
CR1004	7C	7L				R2708	6G	7M	U1001B	6B	7L
CR1005	5D	3L				R2709	6G	7M	U1001C	6B	7L
CR2701	7K	9M	R503	2B	10C	R2710	8G	6M	U1001D	5B	7L
CR2702	8K	9M	R508	2B	10C	R2711	7G	7N	U1101A	7B	4G
CR2703	7K	8N	R510	2B	10C	R2712	7G	7M			
CR2704	7K	6N	R512	3B	10C	R2713	7G	7M	VR2701	7G	6M
CR2705	8G	6M	R906	4E	10B	R2714	7G	7M			
CR2707	7F	7L	R907	4E	10A	R2715	7G	7M			
CR2713	6H	10L	R908	4F	10A	R2716	6G	7M	W9	3M	8N
CR2714	5H	11L	R909	5D	8B	R2717	6H	7M	W9	8A	10M
CR2715	5J	9L	R910	2L	10B	R2718	7J	7M	W9	8M	10M
CR2716	5K	9M	R911	2L	8A	R2719	7J	7M	W16	8A	7K
CR2717	6K	9M	R920	3G	8B	R2720	7J	8N	W900	4A	9B
CR2718	5J	8L	R921	3G	8B	R2721	7K	8N	W1000	5D	4L
			R922	3H	9C	R2722	7K	9N	W1288	8J	6J
DS901	4E	8B	R923	3H	9C	R2723	7K	9M	W2302	3A	10D
DS902	4F	9B	R924	2H	9C	R2724	7K	9M	W2304	4A	11D
DS903	4F	11B	R925	3H	9B				W2701	7E	6M

Partial A10 also shown on diagrams 1, 2, 3, 4, 5, 6 and 15.

OTHER PARTS

J16	7A	CHASSIS	P26	1L	CHASSIS	P27	2L	CHASSIS	V1	1M	CHASSIS
-----	----	---------	-----	----	---------	-----	----	---------	----	----	---------

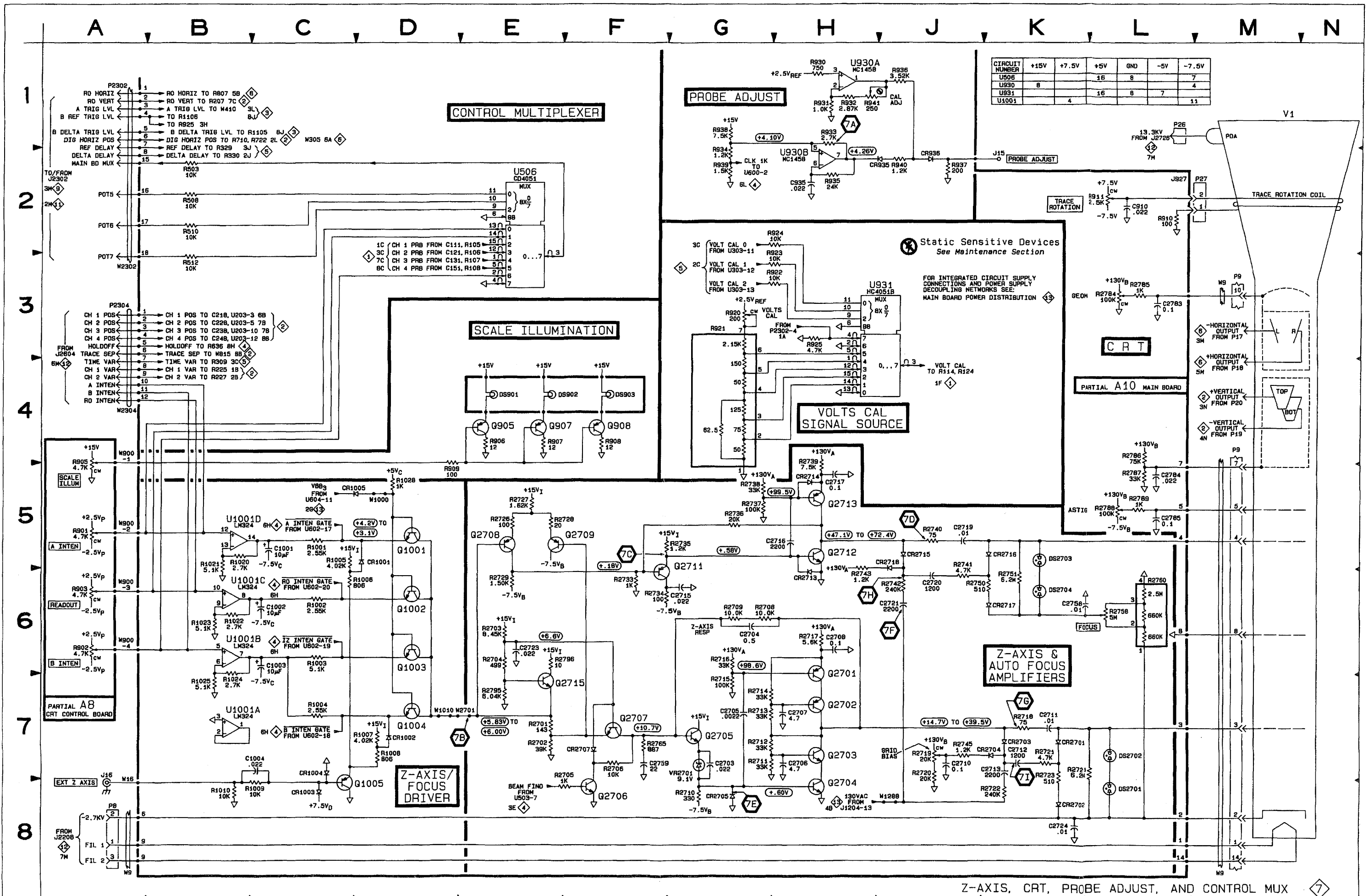

Z-AXIS, CRT, PROBE ADJUST, AND CONTROL MUX

Date: 4-9-91

Change Reference: M70911

Product: 2247A SERVICE

Manual Part Number: 070-6367-00

DESCRIPTION

Product Group 46

EFFECTIVE SERIAL NUMBER: B022499

REPLACEABLE ELECTRICAL PARTS LIST CHANGES

CHANGE TO:

A18RT2201 307-1551-00

RES, THERMAL, 20 OHM, 10%, NTC

DIAGRAM CHANGES

DIAGRAM  POWER SUPPLY

Change the value of resistor RT2201 (location 1A) to 20 Ω .

*This Document is a complete Scan from the original
Tektronix manual*

*For enquiries about our complete
High quality line of technical Manuals in PDF*

mailto : Qservice@otenet.gr

**SEE
OTHER
SIDE**

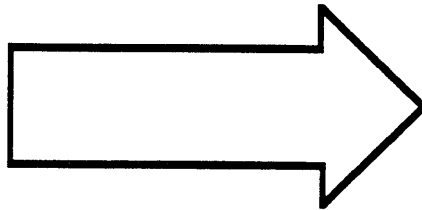

Date: 4-26-91 Change Reference: M72728

Product: 2247A SERVICE MANUAL Manual Part Number: 070-6367-00

DESCRIPTION

Product Group 46

EFFECTIVE SERIAL NUMBER: B022597

REPLACEABLE MECHANICAL PARTS LIST CHANGES

Fig &
Index

Fig & Index No.	Part No.	Qty	NAME & DESCRIPTION
-----------------	----------	-----	--------------------

CHANGE TO:

1-11	213-0942-00	1	SCR,TPG,TR: 6-32 X 0.750 TT, PNH,STL T15 TORX,W/WASHER
3-14	213-0942-00	1	SCR,TPG,TR: 6-32 X 0.750 TT, PNH,STL T15 TORX,W/WASHER
3-42	213-0942-00	1	SCR,TPG,TR: 6-32 X 0.750 TT, PNH,STL T15 TORX,W/WASHER

REMOVE:

3-43	210-0949-00	1	WASHER,FLAT:0.141 ID X 0.5 OD X 0.062,BRS
------	-------------	---	---

*This Document is a complete Scan from the original
Tektronix manual*

*For enquiries about our complete
High quality line of technical Manuals in PDF*

mailto : Qservice@otenet.gr

**SEE
OTHER
SIDE**

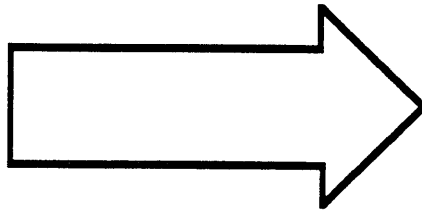

DESCRIPTION

Product Group 46

REPLACEABLE ELECTRICAL PARTS LIST CHANGES

CHANGE TO:

A16	671-0812-02	B022419	CIRCUIT BD ASSY:A16 PROCESSOR (WITHOUT U2519 FIRMWARE)
A16	672-0247-03	B022419	CIRCUIT BD ASSY:A16 PROCESSOR (WITH U2519 FIRMWARE)
A16J1902	131-0589-00	B022149	TERMINAL,PIN:PRESSFIT FIT/PCB;MALE,0.025 (QTY 2)
A16Y2501	119-2936-01	B022502	RESONATOR:16MHZ,CER

ADD:

A16R2545	313-1220-00	B022419	RES,FXD,FILM:22 OHM,5%,0.2W
A16R2565	313-1621-00	B022419	RES,FXD,FILM:620 OHM,5%,0.2W

DIAGRAM CHANGES

DIAGRAM 8 MEASUREMENT PROCESSOR

Add resistor R2545 (22 Ω) from the anode of CR2501 to +5V (grid location 4J).

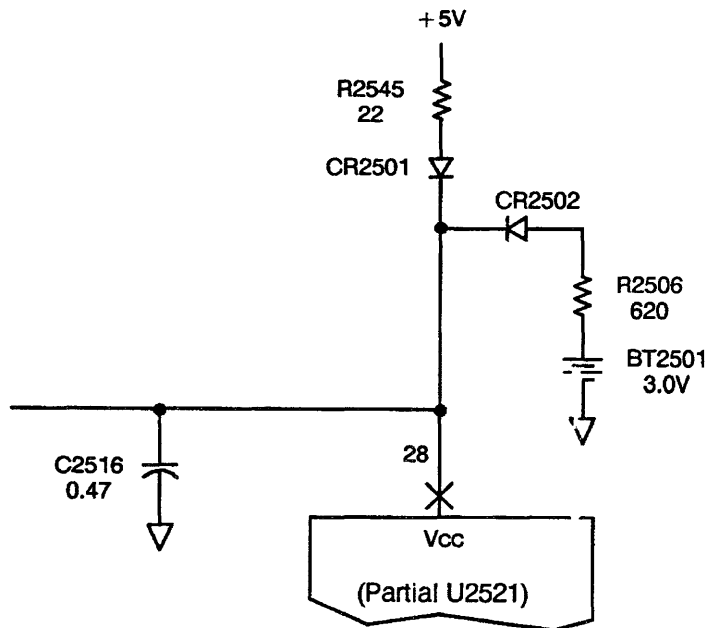

MANUAL CHANGE INFORMATION

Product: 2247A SERVICE

Date: 5-3-91

Change Reference: M71502

DESCRIPTION

Product Group 46

DIAGRAM CHANGES (cont.)

DIAGRAM MEASUREMENT PROCESSOR (cont.)

Add resistor R2565 (620 Ω) from U2501, pin 50, to ground (grid location 6C).

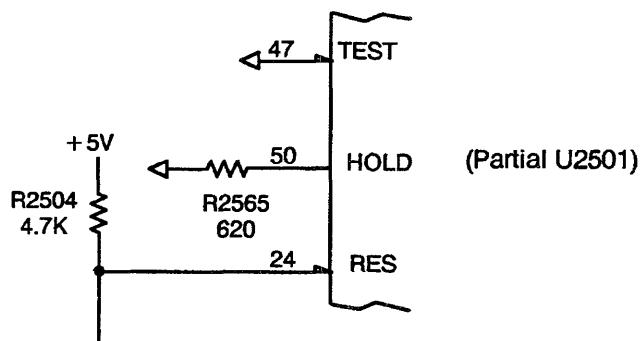

Date: 5-2-91 Change Reference: M71065

Product: 2247A SERVICE MANUAL Manual Part Number: 070-6367-00

DESCRIPTION

Product Group 46

REPLACEABLE ELECTRICAL PARTS LIST CHANGES

CHANGE TO:

A10AT117	307-2135-02	B021488	B022642	ATTENUATOR:1M OHM ATTENUATOR NETWORK
A10AT117	307-2135-03	B022643		ATTENUATOR:1M OHM ATTENUATOR NETWORK
A10AT127	307-2135-02	B021488	B022642	ATTENUATOR:1M OHM ATTENUATOR NETWORK
A10AT127	307-2135-03	B022643		ATTENUATOR:1M OHM ATTENUATOR NETWORK

EFFECTIVE SERIAL NUMBER: B022331

REPLACEABLE MECHANICAL PARTS LIST CHANGES

Fig &
Index

No.	Part No.	Qty	NAME & DESCRIPTION
-----	----------	-----	--------------------

CHANGE TO:

3-36	337-3358-02	1	SHIELD,ATTEN:FRONT,MAIN BD ATTACHING PARTS
------	-------------	---	---

*This Document is a complete Scan from the original
Tektronix manual*

*For enquiries about our complete
High quality line of technical Manuals in PDF*

mailto : Qservice@otenet.gr

**SEE
OTHER
SIDE**

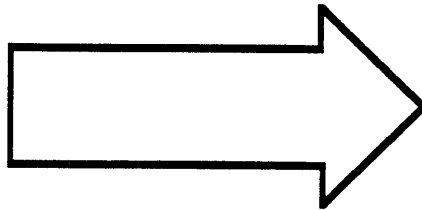

DESCRIPTION

Product Group 46

EFFECTIVE ALL SERIAL NUMBERS

TEXT CHANGES

Page 4-3 Table 4-1

Remove the entries for Digital Delay.

Page 4-28 COUNTER/TIMER

Remove the entry for Digital Delay from the list of equipment required.

Page 4-28 Step 2. Width

Replace the procedure in step 2 with the following:

a. Set:

VERTICAL MODE	CH 1
CH 1 VOLTS/DIV	.2V
A SEC/DIV	1 us
A/B SELECT	A
A SLOPE	
A TRIGGER MODE	AUTO LEVEL
A TRIGGER SOURCE	VERT
A TRIGGER CPLG	DC
TRIGGER LEVEL	12 o'clock

- b. Connect the sine wave generator (SG503) to the CH 1 Input connector via a 50 Ω BNC coaxial cable and a 50 Ω BNC termination.
- c. Set the sine wave generator Frequency to 1 MHz and the Amplitude Multiplier to X1.
- d. Adjust the sine wave generator for 5 divisions of signal.
- e. Position the signal to center screen using the CH 1 POSITION control.
- f. Set CH 1 VOLTS/DIV to 0.1V.
- g. Press the CURSOR VOLTS button. Select (TO AUTO TRACKING MENU). Check that TRACK TRIG LVL is underlined. (If it is not underlined, select TRACK TRIG LVL from the AUTO TRACKING menu.)
- h. Press the COUNTER/TIMER button. Select FREQ.
- i. Adjust the SG503 FREQUENCY VARIABLE for 0.999,000,0 MHz (999.000,00 kHz) to 1.001,000,0 MHz read-out on the CRT.
- j. Press the COUNTER/TIMER button. Select WIDTH.
- k. CHECK—the trigger tracking cursor falls in the vertical center of the waveform. If not, push the LAST MEASUREMENT button and check again.
- l. CHECK—for a readout between 479 and 521 ns.

*This Document is a complete Scan from the original
Tektronix manual*

*For enquiries about our complete
High quality line of technical Manuals in PDF*

mailto : Qservice@otenet.gr

**SEE
OTHER
SIDE**

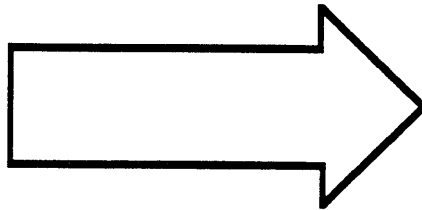

Date: 5-9-91

Change Reference: M73905

Product: 2247A SERVICE

Manual Part Number: 070-6367-00

DESCRIPTION

Product Group 46

EFFECTIVE SERIAL NUMBER: B029233

REPLACEABLE ELECTRICAL PARTS LIST CHANGES

CHANGE TO:

A10R461 322-3143-00

RES,FXD,FILM:301 OHM,1%,0.2W

DIAGRAM CHANGES

DIAGRAM  **A & B TRIGGER
SYSTEM**

Change the value of resistor R461 (location 6K) to 301 Ω .

*This Document is a complete Scan from the original
Tektronix manual*

*For enquiries about our complete
High quality line of technical Manuals in PDF*

mailto : Qservice@otenet.gr

**SEE
OTHER
SIDE**

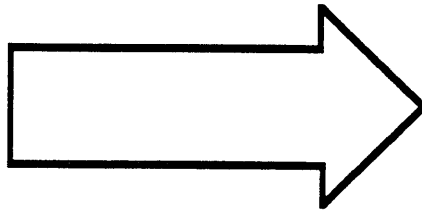

Date: 5-13-91

Change Reference: M73903

Product: 2247A SERVICE MANUAL

Manual Part Number: 070-6367-00

DESCRIPTION

Product Group 46

EFFECTIVE SERIAL NUMBER: B029233

REPLACEABLE ELECTRICAL PARTS LIST CHANGES

CHANGE TO:

A10R113 313-1750-00
A10R123 313-1750-00

RES, FXD FILM:75 OHM,5%,0.2W
RES, FXD FILM:75 OHM,5%,0.2W

DIAGRAM CHANGES

DIAGRAM  VERTICAL INPUTS

Change the value of resistor R113 (location 1G) to 75 Ω .

Change the value of resistor R123 (location 3G) to 75 Ω .

*This Document is a complete Scan from the original
Tektronix manual*

*For enquiries about our complete
High quality line of technical Manuals in PDF*

mailto : Qservice@otenet.gr

**SEE
OTHER
SIDE**

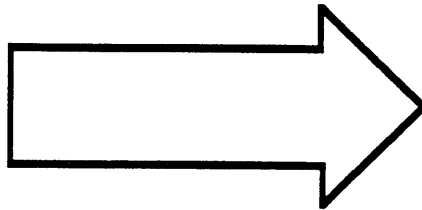

Date: 5-15-91 Change Reference: M74238

Product: 2247A SERVICE MANUAL Manual Part Number: 070-6367-00

DESCRIPTION

Product Group 46

EFFECTIVE SERIAL NUMBER: B030163

REPLACEABLE ELECTRICAL PARTS LIST CHANGES

CHANGE TO:

A18L2206 108-1501-00 INDUCTOR, FIXED: 100UH, 10%, 1.8A

DIAGRAM  POWER SUPPLY

Change L2206 (location 6K) to 100 μ H.

*This Document is a complete Scan from the original
Tektronix manual*

*For enquiries about our complete
High quality line of technical Manuals in PDF*

mailto : Qservice@otenet.gr

**SEE
OTHER
SIDE**

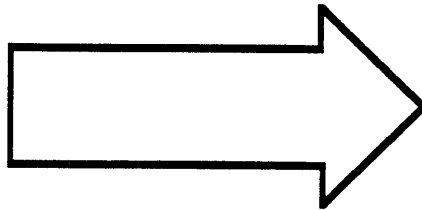



COMMITTED TO EXCELLENCE

MANUAL CHANGE INFORMATION

Date: 5-15-91

Change Reference: M74062

Product: 2247A SERVICE MANUAL

Manual Part Number: 070-6367-00

DESCRIPTION

Product Group 46

(In reference to Change Reference: C2/0589)

EFFECTIVE SERIAL NUMBER: B029146

REPLACEABLE ELECTRICAL PARTS LIST CHANGES

CHANGE TO:

A25 671-1153-01
A25W1502 174-1649-01

CIRCUIT BD ASSY:CHANNEL 2 OUT
CABLE ASSY,RF:50 OHM COAX,21.25 L,W/HARMONICA

ADD:

A25J1502 131-0590-00

TERMINAL,PIN: 0.71 L X .025 SQ PH BRZ,GLD P

*This Document is a complete Scan from the original
Tektronix manual*

*For enquiries about our complete
High quality line of technical Manuals in PDF*

mailto : Qservice@otenet.gr

**SEE
OTHER
SIDE**

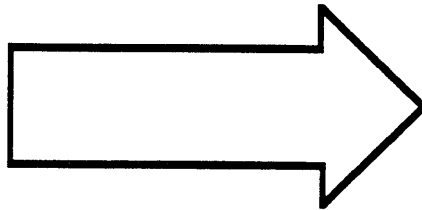

Date: 6-13-91 Change Reference: C7/0691

Product: 2247A SERVICE Manual Part Number: 070-6367-00

DESCRIPTION

Product Group 46

EFFECTIVE ALL SERIAL NUMBERS

CHANGE TO:

A16C1914	281-0904-00	CAP,FXD,CER DI: 12 PF,10%
A16L1901	108-0682-00	COIL,RF: FIXED,61NH
A16Q1903	151-0188-00	TRANSISTOR,SIG: BIPOLAR,PNP,40V,200MA,250MHZ
A16R1937	313-1221-00	RES,FXD,FILM: 220 OHM,5%,0.2W
A16R1938	313-1751-00	RES,FXD,FILM: 750 OHM,5%,0.2W

REMOVE:

A16C1913	281-0819-00	CAP,FXD,CER DI: 33PF,5%,50V
----------	-------------	-----------------------------

*This Document is a complete Scan from the original
Tektronix manual*

*For enquiries about our complete
High quality line of technical Manuals in PDF*

mailto : Qservice@otenet.gr

**SEE
OTHER
SIDE**

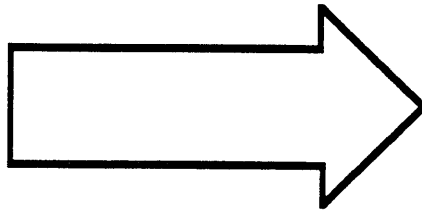

Date: 6-14-91

Change Reference: M72472 (REV)

Product: 2247A SERVICE

Manual Part Number: 070-6367-00

DESCRIPTION

Product Group 46

EFFECTIVE SERIAL NUMBER: B022341

REPLACEABLE ELECTRICAL PARTS LIST CHANGES

CHANGE TO:

A16R1953 313-1222-00
A16R1954 313-1222-00

RES,FXD,FILM: 2.2K OHM.5%,0.2W
RES,FXD,FILM: 2.2K OHM.5%,0.2W

DIAGRAM CHANGES

DIAGRAM  COUNTER/TIMER

Add resistor R1953 (2.2 K Ω) from pin 49 of U1905 to circuit board ground at grid location 6C.
Add resistor R1954 (2.2 K Ω) from pin 47 of U1905 to circuit board ground at grid location 6C.

*This Document is a complete Scan from the original
Tektronix manual*

*For enquiries about our complete
High quality line of technical Manuals in PDF*

mailto : Qservice@otenet.gr

**SEE
OTHER
SIDE**

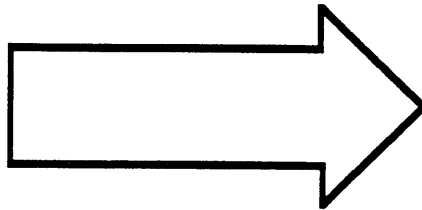

Date: 9-23-91

Change Reference: C8/0991

Product: 2247A SERVICE

Manual Part Number: 070-6367-00

DESCRIPTION

Product Group 46

EFFECTIVE ALL SERIAL NUMBERS

TEXT CHANGES

**Page 4-26 Step 2e. DC Volts Normal Mode
Rejection Ratio**

Change spec to $\pm 0.018V$

*This Document is a complete Scan from the original
Tektronix manual*

*For enquiries about our complete
High quality line of technical Manuals in PDF*

mailto : Qservice@otenet.gr

**SEE
OTHER
SIDE**

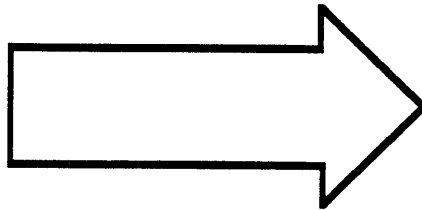

Date: 9-25-91

Change Reference: C9/0991

Product: 2247A SERVICE

Manual Part Number: 070-6367-00

DESCRIPTION

Product Group 46

EFFECTIVE ALL SERIAL NUMBERS

TEXT CHANGES

Page 6-42 Removal and Replacement Instructions – “WARNING”

The component number for the Power Supply/Main Board interface connector mentioned in the warning was incorrectly identified as J1024.

The correct component number is J1204.

The correct warning statement is given below:

WARNING

Potentially dangerous voltages exist at several points throughout this instrument. If it is operated with the cabinet removed, do not touch exposed connections or components. Before replacing parts or cleaning, disconnect the ac power source from the instrument and check that the line rectifier filter capacitors have discharged. Also check the low voltages at the Power Supply/Main Board interface connector (J1204). If any of the supply voltage or line voltage filter capacitors remain charged for more than 20 seconds, discharge them to ground through a 1 k Ω , 5 or 6 watt resistor.

*This Document is a complete Scan from the original
Tektronix manual*

*For enquiries about our complete
High quality line of technical Manuals in PDF*

mailto : Qservice@otenet.gr

**SEE
OTHER
SIDE**

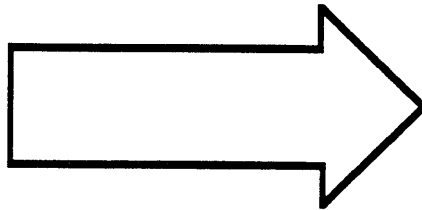

Date: 12-13-91

Change Reference: M76396

Product: 2247A SERVICE MANUAL

Manual Part Number: 070-6367-00

DESCRIPTION

Product Group 46

EFFECTIVE SERIAL NUMBER: B031512

REPLACEABLE ELECTRICAL PARTS LIST CHANGES

CHANGE TO:

A16C1914 281-0811-00

CAPFXD,CER DI:10PF,10%,100V TUBULAR,MI
(NOMINAL VALUE)

A16C1914 281-0904-00

CAPFXD,CER DI:12PF,10% TUBULAR,MI
(TEST SELECTABLE)

DIAGRAM CHANGES

DIAGRAM  COUNTER TIMER

Change the value of capacitor C1914 (location 7F) to SEL (selectable).

*This Document is a complete Scan from the original
Tektronix manual*

*For enquiries about our complete
High quality line of technical Manuals in PDF*

mailto : Qservice@otenet.gr

**SEE
OTHER
SIDE**

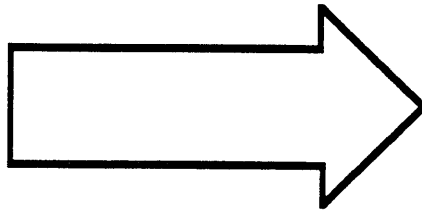

Date: 10-13-92 Change Reference: C10/1092

Product: 2247A SERVICE MANUAL Manual Part Number: 070-6367-00

DESCRIPTION

Product Group 46

EFFECTIVE ALL SERIAL NUMBERS

TEXT CHANGES

Page 4-3 Table 4-1 Test Equipment Required

The part number for the 20 pF precision normalizer is incorrect. The following revised entry for Table 4-1 gives the correct part number:

Precision Normalizer	Input resistance: 1 M Ω : Input Capacitance: 20 pF.	Input capacitance adjustments.	Tektronix Part Number 067-0538-00.
----------------------	---	-----------------------------------	---------------------------------------

*This Document is a complete Scan from the original
Tektronix manual*

*For enquiries about our complete
High quality line of technical Manuals in PDF*

mailto : Qservice@otenet.gr

**SEE
OTHER
SIDE**

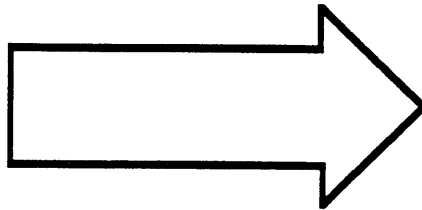

Date: 12-18-92 Change Reference: C11/1292

Product: 2247A SERVICE MANUAL Manual Part Number: 070-6367-00

DESCRIPTION

Product Group 46

EFFECTIVE ALL SERIAL NUMBERS

Page 4-20, Step 6. A and B Magnified Timing Accuracy

Replace part e with the following:

- e. CHECK—that the spacing of the time markers over any 2.5 division interval within the center eight divisions does not deviate by more than 0.37 division. Exclude the first 1/4 division or 25 ns and any portion of the sweep past the 100th magnified division.

*This Document is a complete Scan from the original
Tektronix manual*

*For enquiries about our complete
High quality line of technical Manuals in PDF*

mailto : Qservice@otenet.gr

**SEE
OTHER
SIDE**

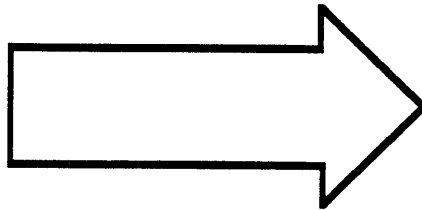

DESCRIPTION

Product Group 46

EFFECTIVE SERIAL NUMBER: B032782

REPLACEABLE ELECTRICAL PARTS LIST CHANGES

CHANGE TO:

A18 670-9398-05

CIRCUIT BD ASSY: LV POWER SUPPLY

A18R2272 303-0100-00

RES, FXD, CMPSN: 10 OHM, 5%, 1W, COMPOSITION OR FILM

A18R2273 303-0100-00

RES, FXD, CMPSN: 10 OHM, 5%, 1W, COMPOSITION OR FILM

REMOVE:

A18R2254 313-1051-00

RES, FXD, FILM: 5.1 OHM, 5%, 0.2W

A18R2255 313-1051-00

RES, FXD, FILM: 5.1 OHM, 5%, 0.2W

ADD:

A18W2254 131-0566-00

BUS, CONDUCTOR: DUMMY RES, 0.094 OD X 0.225L

A18W2255 131-0566-00

BUS, CONDUCTOR: DUMMY RES, 0.094 OD X 0.225L

DIAGRAM CHANGES

DIAGRAM 14 POWER SUPPLY

Change R2272 (location 7K) and R2273 (location 6J) to 10 Ω resistors. Remove and replace R2254 (location 7J) and R2255 (location 6K) with two 0 Ω jumpers, W2254 and W2255.

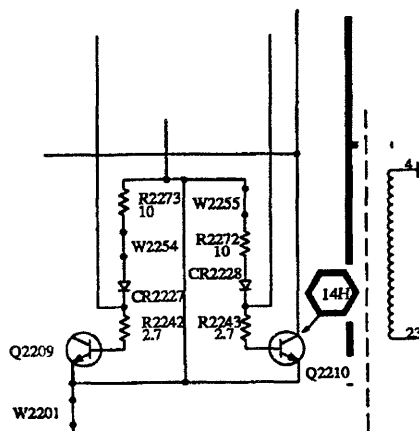

*This Document is a complete Scan from the original
Tektronix manual*

*For enquiries about our complete
High quality line of technical Manuals in PDF*

mailto : Qservice@otenet.gr

**SEE
OTHER
SIDE**

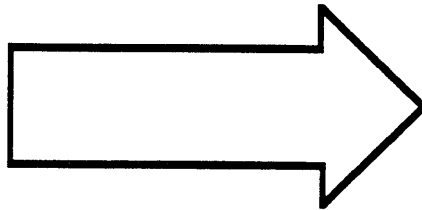

Date: 6-29-93

Change Reference: M77730

Product: 2247A SERVICE MANUAL

Manual Part Number: 070-6367-00

DESCRIPTION

Product Group 46

EFFECTIVE SERIAL NUMBER: B032394

REPLACEABLE ELECTRICAL PARTS LIST CHANGES

CHANGE TO:

A16	671-0812-03	CIRCUIT BD ASSY:PROCESSOR (DOES NOT INCLUDE U2519)
A16	672-0247-00	CIRCUIT BD ASSY:PROCESSOR (INCLUDES U2519)
A16Q1903	151-0220-06	TRANSISTOR,SIG: BIPOLAR, PNP;40V, 200MA, 400MHZ, 2N3906 RES,FXD,FILM:150 OHM,5%,0.2W
A16R1937	313-1151-00	

REPLACEABLE MECHANICAL PARTS LIST CHANGES

Fig &
Index
No.

Part No.

Qty

NAME & DESCRIPTION

ADD:

1-	348-1021-00	1	SHLD GSKT,ELEK:2 LAYER, 0.094 X 0.188 X 37
----	-------------	---	--

DIAGRAM CHANGES

DIAGRAM  COUNTER TIMER

Change the value of resistor R1937 (location 7F) to 150 Ω.

*This Document is a complete Scan from the original
Tektronix manual*

*For enquiries about our complete
High quality line of technical Manuals in PDF*

mailto : Qservice@otenet.gr

**SEE
OTHER
SIDE**

